

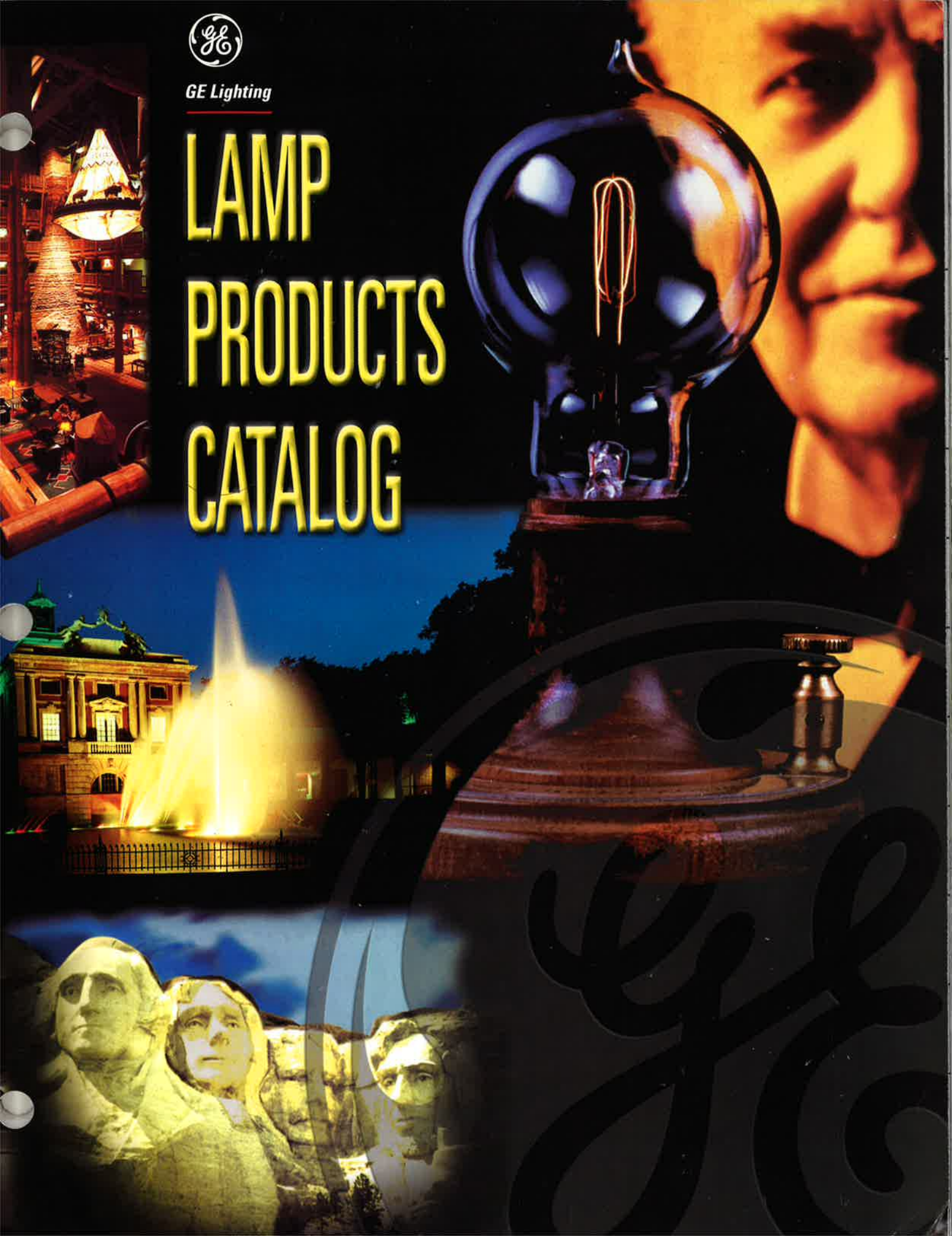

GE Lighting

LAMP PRODUCTS CATALOG





Around the world one brand stands alone—with superior product innovation and customer service. Illuminating the far corners of the earth with the most recognized lighting brand in the industry. Pushing the leading edge of technology to bring good things to light. The brand is GE.

This new edition of the GE Lighting Product Lamp catalog brings together for the first time all major GE Lamp product lines—Incandescent, Halogen, Fluorescent, High Intensity Discharge, Compact Fluorescent, Stage and Studio, Miniature and Sealed Beam, Projection—to meet all your lamp needs in one easy to use, comprehensive buying resource.

In our 120 plus years of lighting leadership we've built our business by helping illuminate yours—in the most effective, cost efficient ways. We're confident this new Lamp Products catalog will help you find exactly what you need. Because being the world's lighting leader is our history and our future. Welcome to the ever-expanding world of GE Lighting products.

Welcome
to the

Ever

Expanding World of Light

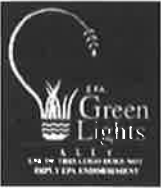

EPA does not endorse any product or service.

This latest edition of the GE Product catalog has been updated to help you more easily select the GE Lighting products that best meet your needs.

Technical data in this catalog (life, lumens, wattage, etc.) are nominal values, subject to manufacturer's tolerances. All technical data in this catalog is based on laboratory tests conducted under controlled conditions. Performance of individual lamps may vary. Because of frequent design improvements, the values listed may not be current ratings. Technical bulletins will be issued from time to time if changes in ratings occur prior to the next catalog printing.

Technical Support
1-800-GE LAMPS
1-888-GE BALLASTS

For the most up-to-date, comprehensive product information, visit the GE Lighting

City of Light
www.ge.com/lighting/business

INTRODUCTION

Section

INCANDESCENT

Section

HALOGEN

Section

HIGH INTENSITY DISCHARGE

Section

FLUORESCENT

Section

COMPACT FLUORESCENT

Section

STAGE AND STUDIO

Section

MINIATURE AND SEALED BEAM

Section

PROJECTION

Section

APPENDIX

Section

I
1
2
3
4
5
6
7
8
A



GE Lighting



Cost of Quality of Light ... The **BIG** picture

80% to 88% of every dollar you spend on the cost of light is spent on electricity.

Save money by investing in the most cost-efficient, energy efficient lamps. It's all a matter of understanding the big picture. Fill out the savings chart below and see for yourself what a difference the right lamps can make.

It's easy to select the best lighting system for your budget with Value*Light™—the most advanced lighting economic analysis software on the market. To learn more about Value*Light call us at 1-800-889-7141.



There are five ways to calculate your savings:

Annual Savings

The total annual savings of lamps, labor and electricity.

Simple Payback

How soon your savings will payback your incremental lamp investment.

Energy Dollars Saved Over Lamp Life

The dollars saved in electricity cost over the life of the bulb.

Return On Investment

The rate of return on your incremental lamp investment.

Savings Over Lamp Life

The total savings of lamps, labor and electricity over the life of the lamp.

Calculate Your Estimated Savings*

Lighting System		Present Lamp Used	Potential Replacement
Lamp Type			
Lamp Life	A	hrs.	hrs.
Lamp Price	B	\$	\$
Lamp Wattage	C	watts	watts
Annual Operating Hours	D		hrs.
Labor \$ Per Relamp	E	\$	
Average Electric Rate	F	\$	kwh
Total Number of Sockets	G		
Annual System Operating Costs			
Lamps	$(B \times D / A) G = H$	\$	\$
Labor	$(E \times D / A) G = I$	\$	\$
Electricity	$(C \times D \times F \times G) / 1000 = J$	\$	\$
Total	$H + I + J = K$	\$	\$
Estimated Savings from New Lamps			
Annual Savings	$K1 - K2 = L$	\$	
Simple Payback	$(B2 - B1) \times G / L = M$		years
Return on Investment	$\frac{L}{G(B2 - B1)} \times 100\% = N$		%
Energy \$ Saved Over Lamp Life	$(J1 - J2) \times A2 / D = O$	\$	
Savings Over Lamp Life	$L \times A2 / D = P$	\$	

* Savings may vary depending on application, fixture and burning position. Stated wattages are approximate. Actual lamp wattage may vary depending on design and manufacturing tolerances.



GREAT COLOR – WITHOUT GIVING UP LIGHT

Now, specially developed rare-earth phosphors provide what conventional phosphors cannot – both high efficiency and good color rendering. Historically, good color rendering lamps, made with conventional phosphors, produced only 60% to 70% of the light of their standard counterparts.

Now, in SP and SPX lamps GE technology has produced color-enhancing fluorescent lamps that actually deliver more light than older standard lamp designs.

- SP lamps use a double coat of conventional and rare-earth phosphors for a moderately priced, good color rendering lamp
- SPX lamps use much more of the rare-earth phosphors for a premium-priced, very good color rendering lamp

See inside back cover for color comparisons.

COLORS FOR SPECIFIC APPLICATIONS

	Warm Tone	Moderate Tone	Cool Tone
RETAIL STORES			
Department, Specialty Discount, Mass Merchandiser	SP30, SPX30 —	SP35, SPX35 SP35, SPX35	— SP41, SPX41
OFFICES			
General Offices Private, Conference, Reception	— SP30, SPX30	SP35 SP35, SPX35	SP41 —
HOSPITALS (all but color-critical areas*)			
	SP30, SPX30	SP35, SPX35	SP41, SPX41
LODGING & FOOD SERVICE			
Meeting Rooms, Offices Living & Dining Areas	— SP30, SPX30	SP35 SPX35	— —
SCHOOLS, UNIVERSITIES			
	—	SP35	SP41
MUSEUMS, ART GALLERIES*			
	SPX30	SPX35	SPX50**
INDUSTRIAL*			
	SP30	SP35	SP41, SPX50**, SP65**

* Color-critical areas such as hospital nurseries, color matching booths and art restoration rooms should use Chroma-50 (C50). The higher efficiency SPX50 color may also be suitable. ** High efficiency daylight-simulating color

SP AND SPX LAMPS

IF YOU NEED:	Better color emphasis than cool white or warm white, plus higher light output...	Brighter, more vibrant colors than even the SP colors, plus the same high light output...
CHOOSE:	SP	SPX
IN A WARM TONE:	SP30 — Especially good for low light levels. Use where you want people and furnishings to look good.	SPX30 — Warm, but brings out high color contrast. Especially good for low light levels where colors must look very good – dining areas, exclusive stores, etc.
IN A MODERATE TONE*:	SP35 — A tone acceptable to nearly everyone. Good for nearly any application where you want people and furnishings to look good.	SPX35 — Moderate tone acceptable to nearly everyone. Brings out colors strongly. Especially good for all kinds of merchandising, and areas such as executive suites, conference rooms... Use wherever colors must look very good.
IN A COOL TONE:	SP41 — A tone similar to cool white, but better color. Especially good for higher light levels wherever people and furnishings must look good.	SPX41 — Cool tone and very good color. Renders all colors well, but emphasizes blues and greens. Use for offices, merchandising areas, and color-important industrial applications.
IN A VERY COOL TONE: (Daylight-simulating)	SP65 — A tone similar to Daylight lamps, but more efficient.	SPX50 — Provides a unique crisp clean look and blends well with outdoor daylight. Use for daylighted spaces, industrial clean rooms, special retailing and commercial areas. Renders all colors well, but emphasizes cool tones. May be too cool for some applications – especially at low light levels.

* The moderate color temperature of the SP35 and SPX35 is usually acceptable to both those who like warm and those who like cool environments. These colors are also useful for well-shielded lighting systems (wedge louvers, deep-cell parabolics) which tend to "cool off" the space visually.



The UNIVERSITY of Light



- World famous headquarters of GE Lighting
- Scheduled conferences to illuminate your world
- Offering world recognized leaders in lighting knowledge
- Bringing leadership in light to life
- Call 1-800-255-1200 for information on available courses

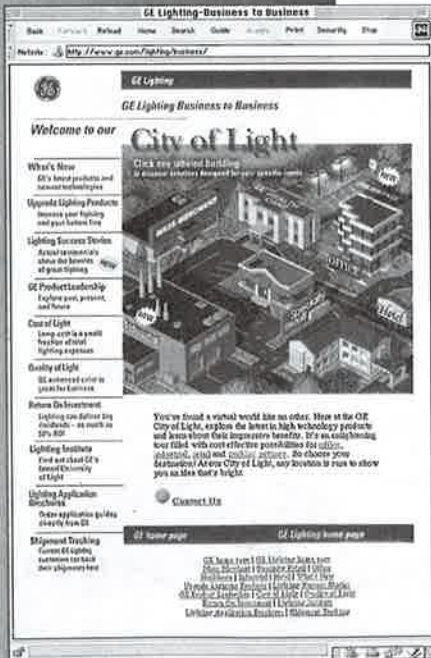

GE Lighting City of LIGHT... your total information RESOURCE

- View product and application information customized to your specific market needs
- Includes a constantly updated What's New section, testimonials of satisfied users and hot button topics such as Cost of Light, Quality of Light and ROI. Plus course schedules and information on the world-renowned GE Lighting Institute... and much more.
- Coming soon... an on-line searchable catalog

www.ge.com/lighting/business

GE TRIPLE-RANGE POCKET LIGHT METERS

LOW COST, HANDY LIGHT METERS FOR GENERAL AND TASK LIGHTING MEASUREMENTS

- Two versions provide direct reading of illuminance
 - Model 217 Footcandle scale (lumens/sq. ft.)
 - Model 216 Lux scale (lumens/sq. meter)
- Convenient size, lightweight and rugged. Perfect for in-the-field lighting survey and verification work.
- Color and cosine corrected - accurate rendering with any general lighting source, electric lighting or downlighting.
- 3 scales plus 10X multiplier provide wide range of light measurements (10-10,000 footcandles or 100-100,000 lux).
- Carrying case and full instructions included.
- Accurate in ambient temperatures from 37°F (3°C) thru 109°F (43°C).

Type 217 Footcandle Scale
Product Code: 21475

Type 216 Lux Scale
Product Code: 22271

Information on price and delivery is available through any GE Lamp Distributor.





GE's exclusive **Halogen-IR™ PAR Lamps** deliver crisp, white halogen light that accents merchandise and decor—plus 68% energy cost savings vs. incandescent PAR and 50% longer life than standard halogens.

GE's upgrade lamps provide the right lighting to attract customers to your store, direct them to targeted merchandise and create the right atmosphere to drive the sale. And it's all made possible with the simple change of a light bulb!

GE upgrade lamps are designed for long life, high quality and low cost of light that can help you put your store, your merchandise and your bottom line in the best possible light.

Optimal lighting can:

- Direct consumers to specific areas and displays.
- Accent and highlight special areas and displays.
- Enhance the colors and accents of merchandise.
- Create a vibrant environment in which to shop.
- Significantly reduce your energy costs.
- Save lamp replacement and labor costs.
- Provide true color rendering for mixing and matching.

Exclusive GE **ConstantColor® Precise™ Lamps** set a new standard for MR16 lighting, providing consistent, white light over life and a long 6,000 hour life. These and other GE-upgrade lamp types featured in this catalog can give your store a dramatic new look at a surprisingly low cost.



GE's exclusive **T8 Fluorescent Lamps with Starcoat™** provide the best color rendering and highest lumen maintenance of any standard T8.



GE's new **ConstantColor® CMH™ Lamps** provide the quality light, consistent color, excellent rendering and color uniformity ordered by retailers—combined with the high efficiencies of HID lighting.

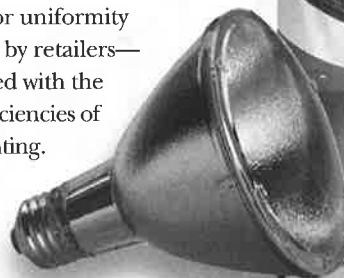

Innovative
retail
lighting is good business.



Innovative Office Lighting is good business.

GE's exclusive **T8 XL Fluorescent Lamps with Starcoat™** last up to 25% longer than standard T8 lamps, while providing the best color rendering and highest lumen maintenance of any standard T8.



Good lighting is good business. Advanced GE lamps can help you put your office in the best possible light. The simple change of a light bulb can dramatically improve your office lighting.

Advanced GE lamps provide the right lighting for enhanced employee comfort and improved efficiency.

GE's **High Lumen Biax® Lamps** feature high light output and efficiencies in a compact, versatile lamp shape. Excellent for use in conference rooms, lobbies, dining rooms and other applications where color is important.

- Optimal lighting can:*
- Help create more attractive and appealing surroundings.
 - Create a pleasing environment in which to work.
 - Increase productivity and reduce absenteeism.
 - Significantly reduce your energy costs.
 - Save lamp replacement and labor costs.
 - Give your business an exciting new look.

GE's new **ConstantColor® CMH™ Lamps** provide quality light, consistent color temperature and excellent color rendering—perfect for the executive office or conference room.

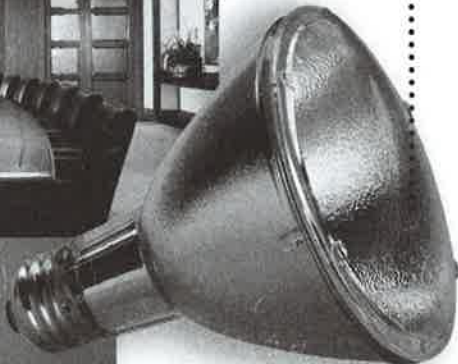

GE's exclusive **Halogen-IR™ PAR Lamps** are the most efficient halogen lamps made, offering up to 60% energy savings vs. incandescent PAR and 50% longer life than standard halogens.

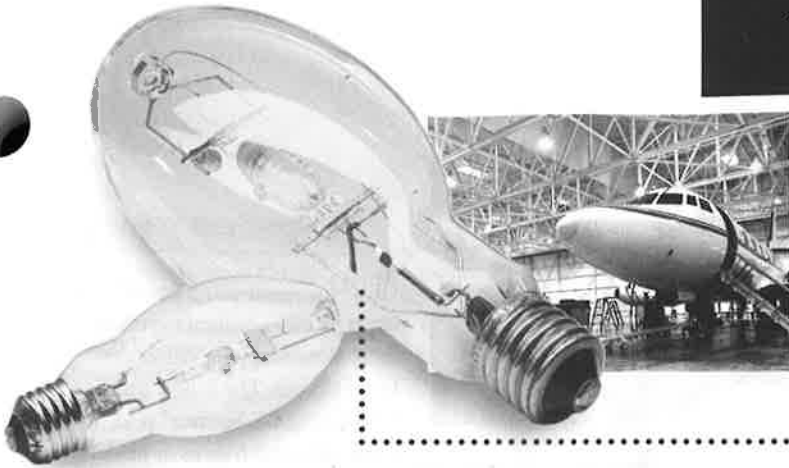

GE's Extra-High Output-XHO Multi-Vapor® provides up to 22% more light than standard 400-watt universal burn metal halide lamps.

Advanced GE lamps provide the right lighting to maintain cost efficiency, while improving employee comfort and productivity.

Advanced GE lamps can help you put your industrial workplace in the best possible light. The simple change of a light bulb can dramatically improve your industrial lighting.

GE's PulseArc™ Multi-Vapor® combined with new ballasts and ignitors, features the highest initial light output and the best lumen maintenance performance in the industry.

GE's ChromaFit™ Multi-Vapor® directly replaces high pressure sodium lamps, providing improved white color without expensive system changes.

Optimal lighting can:

- Significantly reduce your energy costs.
- Create a pleasing environment in which to work.
- Increase productivity.
- Improve employee accuracy in all phases of production.
- Help create more attractive and appealing surroundings.



GE's efficient Watt-Miser® Multi-Vapor® easily upgrades standard 175-watt and 400-watt metal halide lamps to reduce energy costs, saving up to \$64.00 per socket (10¢ per kwh).



GE's Ecolux® and Ecolux® XL Reduced Mercury Fluorescents pass TCLP test, substantially lowering disposal cost where applicable. Plus, the best color and more light over life than any standard T8.



Innovative **industrial** lighting is good business.



Innovative Hospitality

lighting is good business.



GE's blue neodymium **Enrich™** lamp provides enhancing white light. Rooms appear richer and more vibrant. The tough and long-lasting **GE Survivor™** is ideal for hard-to-reach spots or places where routine impact might damage regular bulbs.

Advanced GE lamps can help put your hotel, motel, restaurant and meeting rooms in the best possible light. The simple change of a light bulb can dramatically improve your lighting and your bottom line.



GE upgrade lamps help you set the mood for superior hospitality, while lowering your total cost of light.



GE's line of **Compact Fluorescent Lamps** provide dramatic energy savings and long life for low maintenance costs in a variety of applications from downlights to table lamps.

Optimal lighting can:

- Help create more attractive and appealing surroundings for guests.
- Give your facility an exciting new look.
- Provide good task lighting in guest rooms for grooming and on-the-road business work.
- Enhance the safety and security of your guests.
- Significantly reduce your energy costs.
- Save lamp replacement and labor costs.

GE's exclusive **Halogen-IR™ PAR Lamps** are the most efficient halogen lamps made, offering up to 60% energy cost savings vs. incandescent PAR and 50% longer life than standard halogens.

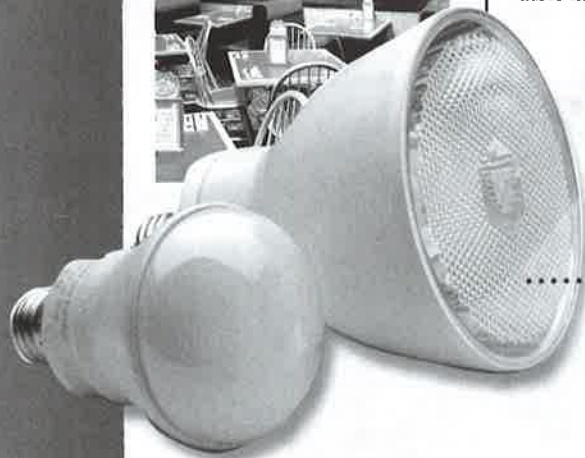

GE's exclusive 23-watt **Genura® Reflector Lamps** combine energy savings and greater light output than a 75-watt R30 lamp, with the longest life of any compact fluorescent—15,000 hours. Replace your reflector floods with **GE's Biax® Fluorescent Reflector**, and you'll save up to 80% on energy costs.



GENERAL INFORMATION

Bulb Identification Guide	1-2
Filament Identification	1-2
Base Identification	1-2
Lamp Locator	1-3
Introduction	1-4
GE Watt-Miser® A-Line Bulbs	1-5
GE Survivor® A-Line Bulbs	1-5
GE COV-R-GUARD™ A-Line Bulbs	1-5
GE Long Life Floodlight or Spot	1-5
Catalog Headings	1-6
General Information	1-32
Footnotes	1-32

INCANDESCENT LAMPS

3 WATTS	1-7
4 WATTS	1-7
6 WATTS	1-7
7 WATTS	1-7
7.4-7 1/2 WATTS	1-7
7 1/2 WATTS	1-8
10 WATTS	1-8
11 WATTS	1-8
12-13 WATTS	1-8
15 WATTS	1-8
15-135-150 WATTS	1-8
18 WATTS	1-9
20-24 WATTS	1-9
25 WATTS	1-9
30 WATTS	1-10
30-70-100 WATTS	1-11
33 WATTS	1-11
40 WATTS	1-11
45 WATTS	1-12
50 WATTS	1-12
50-50 WATTS	1-13
50-100-150 WATTS	1-13
50-200-250 WATTS	1-13
60 WATTS	1-14
67 WATTS	1-16
75 WATTS	1-17
80-170-250 WATTS	1-17
85 WATTS	1-18
88 WATTS	1-18
100 WATTS	1-18
100-200-300 WATTS	1-20
110 WATTS	1-20
116 WATTS	1-20
120 WATTS	1-20
125 WATTS	1-21
150 WATTS	1-22
175 WATTS	1-23
200 WATTS	1-23
240 WATTS	1-24
250 WATTS	1-24
300 WATTS	1-25
350 WATTS	1-26
375 WATTS	1-26
400 WATTS	1-26
500 WATTS	1-26
750 WATTS	1-27
1000 WATTS	1-27
1500 WATTS	1-27
By Amperes	1-27

WATT-MISER® LAMPS

27 WATTS	1-10
65 WATTS	1-15
85 WATTS	1-18
120 WATTS	1-20

WATT-MISER® AND WATT-MISER® PLUS LAMPS

34 WATTS	1-11
52 WATTS	1-14
54 WATTS	1-14
55 WATTS	1-14
60 WATTS	1-14
67 WATTS	1-16
90 WATTS	1-18
120 WATTS	1-21
135 WATTS	1-21

MISER® LAMPS

70 WATTS	1-16
95 WATTS	1-18

E-27 BASE - EXPORT LAMPS

80 WATTS	1-17
100 WATTS	1-20
120 WATTS	1-21
150 WATTS	1-23

EXPORT PAR LAMPS

300 WATTS	1-25
-----------------	------

LUMEN RATED TRAFFIC SIGNAL LAMPS

Extended Group Replacement Service	1-27
--	------

AIRPORT LAMPS

30 WATTS	1-28
40 WATTS	1-28
45 WATTS	1-28
120 WATTS	1-28
200 WATTS	1-28
204 WATTS	1-28
210 WATTS	1-28
503 WATTS	1-28
620 WATTS	1-28
1000 WATTS	1-28
1200 WATTS	1-28

MULTIPLE STREET LIGHTING LAMPS

Group Replacement Service	1-28
Extended Group Replacement Service	1-28

DECORATIVE LAMPS

15 WATTS	1-29
25 WATTS	1-29
40 WATTS	1-29
60 WATTS	1-30
100 WATTS	1-31
150 WATTS	1-31

PORTABLE LIGHTING PRODUCTS

75 Watts	1-31
----------------	------

INCANDESCENT LAMPS - INTERNATIONAL EXPORT ONLY

Multiple Wattages	1-31
-------------------------	------



BULB IDENTIFICATION

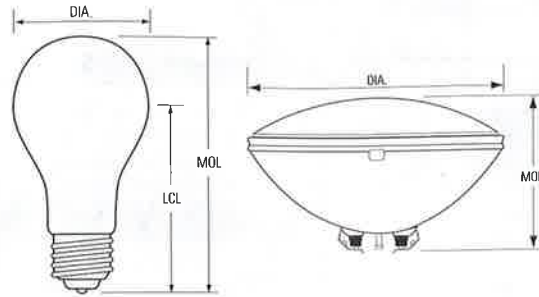

DIA: Diameter of bulb at widest point.
 MOL: Maximum Overall Length including base or pins.
 LCL: Distance between the center of the arc tube and the Light Center Length reference plane.
 Note: Lamp drawings are not drawn to scale. Be sure to check size and dimension information when identifying each lamp.

To convert inches to millimeters, multiply the dimension (in inches) by 25.4 (i.e. 1.5" x 25.4 = 38.1 mm).

FILAMENT IDENTIFICATION

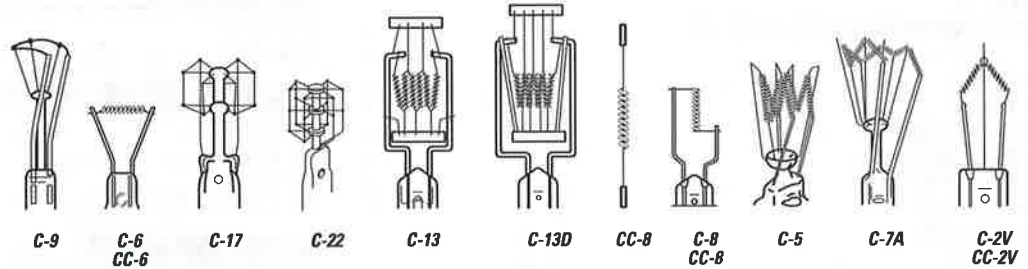

BASE IDENTIFICATION

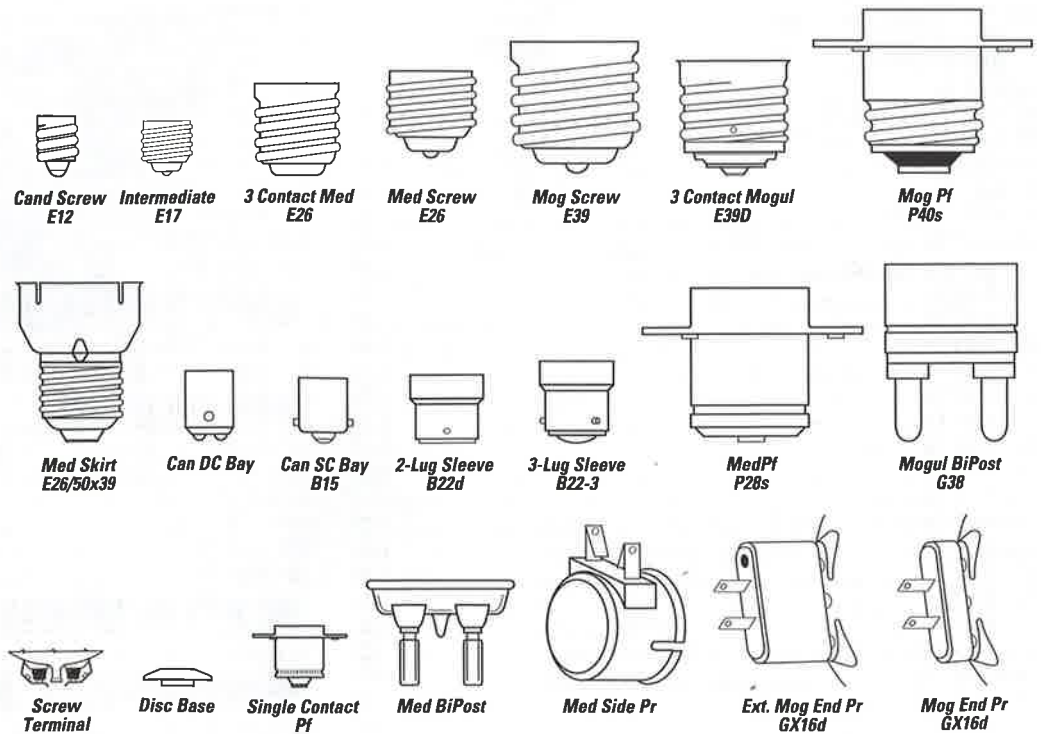



LAMP LOCATOR

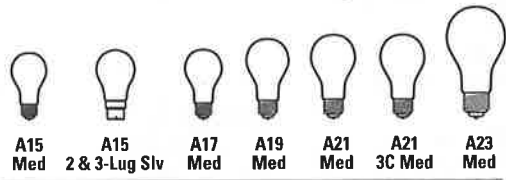

Lamp Shape A



Lamp Shape B

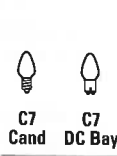

Lamp Shape C

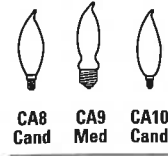

Lamp Shape CA

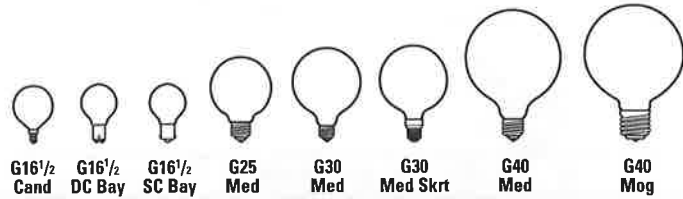

Lamp Shape G

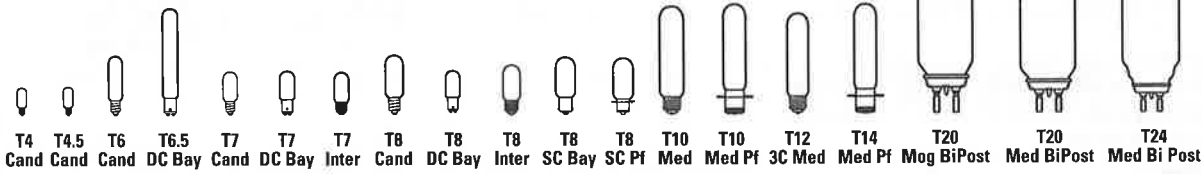
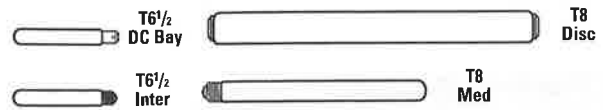

Lamp Shape T



Lamp Shape TB

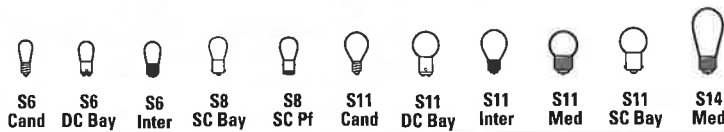

Lamp Shape S

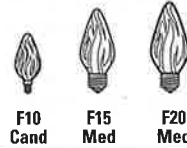

Lamp Shape F



Lamp Shape RP



Lamp Shape E



Lamp Shape ER



Lamp Shape BR



Lamp Shape R



Lamp Shape P

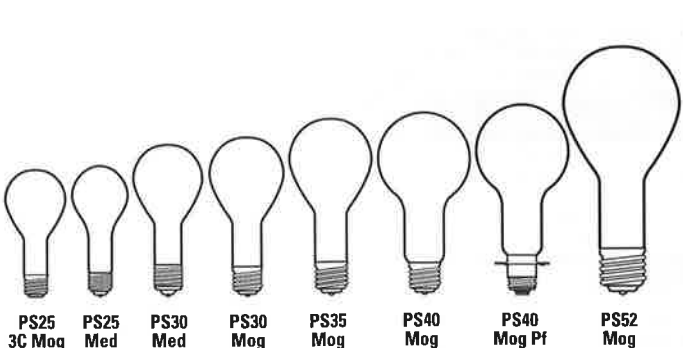

Lamp Shape PS

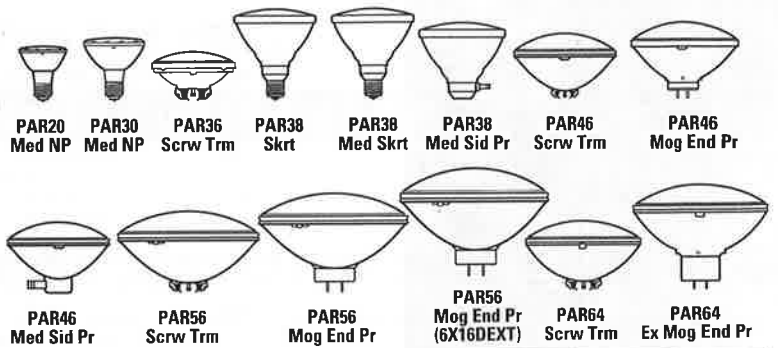

Lamp Shape PAR



INTRODUCTION

GE Lighting's incandescent lamps trace their ancestry to the world's first practical electric bulb, invented by Thomas Alva Edison, founder of General Electric Company, in 1879.

More than a century of research and development later, the present range of GE incandescent lamps represents the state of the art of lamps for residential and commercial use, as well as special purpose lamps for decorative or display applications.

In an incandescent lamp, light is generated by heating the filament to incandescence. The hotter the filament, the more efficient it is in converting electricity to light. However, when the filament operates hotter, its life is shortened so the design of each lamp is a balance between efficiency and life. This is why lamps of equal wattage may have different lumen ratings and different life ratings.

Incandescent lamps of similar size are commonly available with different wattage ratings. The fixture wattage limit should not be exceeded.

PROTECTION FROM MOISTURE

When **HRG** (Hard Glass) appears in the Lamp Description column, the outer bulbs are made of special thermal-shock-resistant glass. However, sometimes external protection of the lamps is also needed to eliminate the chance of bulb breakage due to contact with water during operation. Footnotes will indicate when external protection is needed. Where **HRG** is not shown, the bulb glass is such that the lamps require protection from exposure to mist or condensation as well as direct contact with water during operation.

RATED AVERAGE LIFE

Values are based on a large number of representative lamps under controlled conditions. Individual lamps or groups of lamps may vary from the Rated Average Life shown. Rated Average Life is a median value of life expectancy – the total operating time at which under normal conditions 50% of any large group of initially installed lamps are expected to be still burning.

BASES

When Footnote 23 or **BB** (Brass Base) appears in the Lamp Designation or Description column, the lamp is supplied only with a brass base. Brass Bases are recommended for outdoor lighting applications.

BURNING POSITION

Limitations on lamp operating position are shown in the Description column.

The following abbreviations are used:

BDTH (Burn lamp in Base Down To Horizontal Position)

BUTV (Burn lamp in Base Up To Vertical Position).

GE	Osram/Sylvania	Phillips
INCANDESCENT BRAND NAME CROSS-REFERENCE		
House Garden™ – Bug-Lite	Bug Lite	Bug-A-Way
Cool Beam	Cool-Lux	Cool Beam
Cov-R-Guard™	Safeline	Silicone Coated
Saf-T-Gard®	—	—
Soft Pink	Soft Pink	Softone Pastels
Soft White Miser®	Energy Saver Soft White	Energy Saving
Extended Service	Excel-Line®	Extended Service
House Garden™ – Plant Light	Spot-GRO	Agro-Lite
Long Life Soft White	Double Life™ Soft White	Longer Life Soft White
Lumiline	Lumiline	Philinea
Party Light	—	—
Survivor™	—	Industrial Service
Watt-Miser®	Super Saver®	Econ-o-Watt
Watt-Miser® PAR	Super Saver Par®	Econ-o-Par
Watt-Miser® Plus	Super Saver Excel®	Extended Service

ATTENTION: This brand-name cross-reference chart is provided only as a quick reference. Other lamp company brand listings may only represent a near equivalent, versus an identical match to GE brands. Individual lamp manufacturers' product offerings and performance specifications should be consulted. Lamp performance may be affected by environmental conditions, and/or auxiliary equipment.



GE WATT-MISER® A-LINE BULBS

Replaces standard incandescent bulbs* for...

- 33% longer life
- 10-15% energy cost savings
- Available in 34-135 watts to replace 40-150 watt standard bulbs
- For even longer life – 2500 hours – use Watt-Miser® Plus (WMP) bulbs

* Some loss of light, depending on wattage selected, when replacing standard bulbs. See catalog listing for lumen ratings.

GE SURVIVOR™ A-LINE BULBS

Built to last, even under many "rough" service conditions...

- Five filament support design protects against early burnouts caused by bumps, jars and vibration
- Longer life... lasts 3000 hours. 3-4 times longer than standard bulbs*
- Popular wattages available
- Economically priced
- Best A-line choice for general commercial/industrial use

* Survivor bulbs provide a 300%-400% increase in life with 68%-75% of the light of ordinary bulbs.

GE COV-R-GUARD™ A-LINE BULBS

- Teflon®* coating is shatter and weather-resistant
- Resists breakage from heat and thermal shock that can occur from water, sleet, snow, molten solder, and weld spatter
- Wide choice of wattages and voltages
- Rough service version available for extra tough conditions

Uses:

Construction sites, loading docks, string lighting, elevators, trouble light, metal fabricating, food processing areas, farms.

* Teflon is a registered trademark of DuPont.

GE LONG LIFE FLOODLIGHT OR SPOTLIGHT

- 25% longer life than standard reflectors. Ideal for use in high ceilings and hard to reach track lighting.
- Easy replacement – same length and width as standard R bulbs.
- Some lumen loss from standard reflectors (See listing for lumen values).
- Available in 45w floodlight and 65w floodlight and spotlight.

Uses:

Down lighting, display lighting, accent lighting, wall washing. Wherever standard reflector bulbs are used.

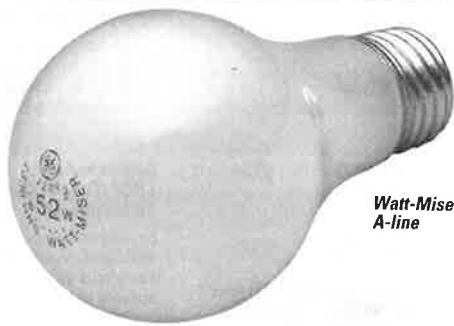

Watt-Miser®
A-line

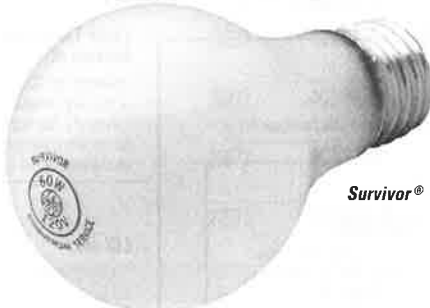

Survivor®

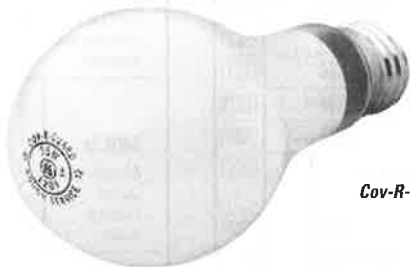

Cov-R-Guard™



Long Life
BR30 Reflector
Floodlight or
Spotlight

Standard Lamp	40-watt 1000 hr.	60-watt 1000 hr.	75-watt 750 hr.	100-watt 750 hr.	150-watt 750 hr.
---------------	---------------------	---------------------	--------------------	---------------------	---------------------

ENERGY SAVINGS OVER LAMP LIFE WITH WATT-MISER® BULBS

Energy-Saving Replacement	Replace with 34-watt Watt-Miser® 2000 hr.(1)	Replace with 52-watt Watt-Miser® 1330 hr.(2)	Replace with 67-watt Watt-Miser® 1000 hr.(3)	Replace with 90-watt Watt-Miser® 1000 hr.(4)	Replace with 135-watt Watt-Miser® 1000 hr.(5)
---------------------------	--	--	--	--	---

10¢ KWH Rate

\$1.20	\$1.06	\$1.07	\$1.33	\$2.00
--------	--------	--------	--------	--------

(1) 40-watt 1000 hr, 505 lumens compared to 34-watt 2000 hr, 380 lumens
 (2) 60-watt 1000 hr, 865 lumens compared to 52-watt 1330 hr, 730 lumens
 (3) 75-watt 750 hr, 1190 lumens compared to 67-watt 1000 hr, 1030 lumens
 (4) 100-watt 750 hr, 1710 lumens compared to 90-watt 1000 hr, 1465 lumens
 (5) 150-watt 750 hr, 2850 lumens compared to 135-watt 1000 hr, 2380 lumens



HEADINGS IN THIS CATALOG SECTION

The following terms and descriptions can help you when checking Incandescent lamp specifications and when ordering products. Within this product line, lamps are divided by wattage. Within wattage, lamps are listed alphabetically by bulb shape.

 Indicates that this is a reduced wattage option for lamps normally used in this application. Be sure to check wattage, lumens and life to determine which lamp is best suited to your needs.

Bulb:

Bulb shape followed by its size (the maximum diameter of the bulb expressed in eighths of an inch).

Product Code:

It is important to use this five-digit code when ordering to ensure that you receive the exact product you require.

Base:

The type of base.

Lamp Description:

The lamp's identification code.

Case Quantity:

Number of product units packed in a case.

Volts:

Lamp data is based on operation at rated voltage.

Energy Used-Nominal Watts:

Energy Used (as defined by FTC Lamp Label Rules). To estimate energy consumption (kWh), multiply watts x hours of use and divide by 1000.

Light Output-Lumens:

Light output (as defined by FTC Lamp Label Rules) is rated average lumens.

Additional Information:

Typical application and/or other important information, including footnotes (*).

Approximate Beam Spread:

For reflector type lamps. The total angle of the directed beam (in degrees) to where the intensity of the beam falls to 50% of the maximum value.

Approximate CBCP (Center Beam Candlepower):

For reflector type lamps. Center Beam Candlepower is the intensity (candelas) at the center or maximum intensity of the beam.

Color Temperature - Kelvins (K):

"Warmth" or "Coolness" of the lamp, measured in Kelvins (K). The higher the temperature, the cooler the appearance of the light.

LCL in.:

Distance between the center of the filament and the Light Center Length reference plane, in inches.

MOL in.:

Maximum Overall Length in inches.

Bulb	Base	Product Code	Lamp Description	Volts	Case Qty.	Additional Information	Lumens	Watts	Hours	Life	Filament Design	MOL in.	LCL in.	Color Temp. K	Approx. CBCP	Approx. Beam Spread
------	------	--------------	------------------	-------	-----------	------------------------	--------	-------	-------	------	-----------------	---------	---------	---------------	--------------	---------------------

WATT-MISER® AND MISER® LAMPS

65 WATTS

BR30	Med	14264	75R30/SP/65WM	130	24	Reflector Spot (4, 35, 56)*	725	65	2000		CC-6	5 7/8				
------	-----	-------	----------------------	-----	----	-----------------------------	-----	----	------	--	------	-------	--	--	--	--

75 R30/ SP/ 65WM

Identifies the lamp's wattage.

Identifies the lamp's shape.

Identifies the lamp as a spotlight.

Identifies the lamp as a Watt-Miser®

WHEN YOU DON'T KNOW THE LAMP DESCRIPTION

1. Identify the lamp wattage.
2. Measure bulb diameter using ruler in appendix LCL on page A-1 to determine width in eighths of an inch.
3. Identify base type using table on page 1-2.
4. Find your lamp in the table containing the bulb wattage, then match the shape, size and base, which are all listed alphabetically.



Bulb	Base	Product Code	Lamp Description	Volts	Case Qty.	Additional Information	Lumens	Watts	Life Hours	Filament Design	MOL in.	LCL in.	Color		Approx. Beam Spread
													Temp. K	Approx. C	
INCANDESCENT LAMPS															
3 WATTS															
	S6	Cand	11098	3S6/5 24PK	130	24	Clear-Indicator	11	3	3000	C-7A	1 7/8	1 3/8		
4 WATTS															
	C7	Cand	43050	4C7 CD/2	120	240	Long Life Clear Night Light (9, 101)*	4	3000	C-7A	2 1/8				
			16001	4C7/W CD/2	120	240	White-Long Life Night Light (9, 101)*	4	3000	C-7A	2 1/8				
			26223	4C7/BL-CD2 6PK	120	240	Long Life Blue Night Light (9, 101)*	4	3000	C-7A	2 1/8				
			26222	4C7/PK-CD2 6PK	120	240	Long Life Pink Night Light (9, 101)*	4	3000	C-7A	2 1/8				
			20572	4C7/S CD/4	120	120	Standard Clear Night Light (44, 101)*	4	2000	C-7A	2 1/8				
			20573	4C7/W/S CD/4	120	120	Standard White Night Light (44, 101)*	4	2000	C-7A	2 1/8				
6 WATTS															
	S6	Cand	11316	6S6 24PK	12	24	Clear-Indicator	50	6	1500	C-2V	1 7/8	1 3/8		
			11329	6S6	24	240	Clear-Indicator	50	6	1500	C-2V	1 7/8	1 3/8		
			11331	6S6 24PK	30	24	Clear-Train	50	6	1500	C-2V	1 7/8	1 3/8		
			43397	6S6/BB	32	24	Clear-Train, BB (23)*	50	6	1500	C-2V	1 7/8	1 3/8		
			11577	6S6/3	120	240	Clear-Signal Light (6)*	23	6	5000	C-7A	1 7/8	1 3/8		
			11367	6S6 TRAY	120	240	Clear-Indicator. 12-Lamp Tray	41	6	1500	C-7A	1 7/8	1 3/8		
			15820	6S6 CD/2	120	240	Clear-Indicator (9)*	41	6	1500	C-7A	1 7/8	1 3/8		
			11369	6S6 TRAY	130	240	Clear-Indicator. 12-Lamp Tray	41	6	1500	C-7A	1 7/8	1 3/8		
			11372	6S6	145	240	Clear-Indicator	41	6	1500	C-7A	1 7/8	1 3/8		
			11374	6S6	155	240	Clear-Indicator	41	6	1500	C-7A	1 7/8	1 3/8		
		Inter	11660	6S6/7 24PK	120	24	Clear-Indicator. 12-Lamp Tray	41	6	1500	C-7A	1 13/16	1 1/16		
		DC Bay	11357	6S6DC 24PK	75	24	Clear-Indicator	45	6	1500	C-7A	1 13/16	1 7/16		
			11592	6S6DC TRAY	120	240	Clear-Indicator. 12-Lamp Tray	41	6	1500	C-7A	1 13/16	1 7/16		
			11594	6S6DC TRAY	130	240	Clear-Indicator. 12-Lamp Tray	41	6	1500	C-7A	1 13/16	1 7/16		
			11609	6S6DC 24PK	145	24	Clear-Indicator. 12-Lamp Tray	41	6	1500	C-7A	1 13/16	1 7/16		
	T4 1/2	Cand	11764	6T4 1/2/1	130	100	Clear-Indicator	42	6	1500	C-7A	1 7/8	1 5/16		
7 WATTS															
	C7	Cand	11779	7C7 TRAY	120	240	Clear-Indicator. 12-Lamp Tray	46	7	3000	C-7A	2 1/8			
			11792	7C7 TRAY	130	240	Clear-Indicator. 12-Lamp Tray	46	7	3000	C-7A	2 1/8			
			11815	7C7/W TRAY	120	240	White-Indicator. 12-Lamp Tray	36	7	3000	C-7A	2 1/8			
7.4-7 1/2 WATTS															
	T6 1/2	DC Bay	43409	7.4T6 1/2 DC/F	10.5	60	Frost-Exit Sign	55	7	10000	C-8	5 1/2			
	S11	Med	41267	7 1/2 S/CW CARD	120	240	White (101)*	39	7.5	1400	C-9	2 1/4			
			11922	7 1/2 S/CW TRAY	130	240	White-12-Lamp Tray	39	7.5	1400	C-9	2 1/4			
			11847	7 1/2 S TRAY	120	240	Clear-12-Lamp Tray	53	7.5	1400	C-9	2 1/4			
			11848	7 1/2 S TRAY	130	240	Clear-12-Lamp Tray	53	7.5	1400	C-9	2 1/4			
			11880	7 1/2 S/CG TRAY	120	240	Green-12-Lamp Tray	7.5	1400	C-9	2 1/4				

To save energy costs, find the bulbs with the light output you need, then choose the one with the lowest watts. To convert inches to millimeters, multiply by 25.4.
 © Means this lamp meets Federal Minimum Efficiency Standards. (*) * All footnote references found at the end of this section. Reduced Wattage



Bulb	Base	Product Code	Lamp Description	Volts	Case Qty.	Additional Information	Lumens	Watts	Life Hours	Filament Design	MOL in.	LCL in.	Color Temp. K	Approx. Beam Spread	
INCANDESCENT LAMPS															
7 1/2 WATTS															
	S11	Med	11911	7 1/2S/CR TRAY	130	240	Red-12-Lamp Tray	7.5	1400	C-9	2 1/4				
10 WATTS															
	C7	DC Bay	11994	10C7DC TRAY	120	240	Clear-Indicator, 12-LampTray (6)*	40	10 5000	C-7A	2 1/8				
	S6	Cand	12041	10S6/10 24PK	230	24	Clear-Indicator	66	10 1500	C-7A	1 7/8	1 3/8			
			12050	10S6/10 24PK	250	24	Clear-Indicator	66	10 1500	C-7A	1 7/8	1 3/8			
	S11	DC Bay	12060	10S6/10DC 24PK	230	24	Clear-Indicator	66	10 1500	C-7A	1 14/16	1 7/8			
		Cand	12249	10S11/79	120	120	Clear-Indicator	80	10 1500	C-7A	2 1/4	1 9/16			
	Inter	12188	10S11N/F	120	120	Frost-Appliance	79	10 1500	C-7A	2 5/16	1 5/8				
		12186	10S11N	120	120	Clear-Sign, BB (23)*	80	10 1500	C-7A	2 5/16	1 5/8				
		12185	10S11N	130	120	Clear-Sign, BB (23)*	80	10 1500	C-7A	2 5/16	1 5/8				
11 WATTS															
	S14	Med	12575	11S14	130	120	Clear-Sign, BB (23)*	77	11 3000	C-9	3 1/2	2 1/2			
			12589	11S14/IF	130	120	I.F.-Sign, BB (23)*	76	11 3000	C-9	3 1/2	2 1/2			
			12621	11S14/R	130	120	Red-Sign, BB (23)*	11	3000	C-9	3 1/2				
			12632	11S14/Y	130	120	Yellow-Sign, BB (23)*	11	3000	C-9	3 1/2				
12-13 WATTS															
	S8	SC Bay	10690	12S8/93T-6PK CD/2	12	240	Low Voltage, High Intensity (9, 66, 74)*	200	12 1000	C-2R	2	1 1/4			
	S11	SC Bay	12649	13/3 1/2S11/95	10	120	Clear-Railway Signal Light, Filament in multiple (70)*	180	13.5 1000	CC-6 C-12	2 3/8	1 1/4			
15 WATTS															
	A15	Med	12658	15A15	130	120	Inside Frost	125	15 2500	C-9	3 1/2	2 3/8			
			16215	15A15/CL/BB	130	120	Clear-Sign, BB (23)*	110	15 3000	C-9	3 1/2	2 3/8			
			41270	15A/W 24PK	120	120	Soft White	110	15 2500	C-9	3 1/2				
			12784	15A	34	120	I.F.-Train (53)*	180	15 1000	C-9	3 5/8	2 3/8			
	R14	SC Bay	33404	15R14SC/SP	12	120	Reflector Spot Light-Inside Frost, BB (4, 23)*	135	15 2000	CC-8	2 5/8				
	S11	Cand	13236	15S11/14	120	120	Clear-Medical Spot	150	15 200	C-7A	2 1/4	1 3/8			
			13210	15S11/13	120	120	Clear	137	15 750	C-7A	2 1/4	1 9/16			
		DC Bay	13188	15S11/3DC	75	120	Clear-Train	138	15 1000	C-9	2 3/8	1 1/4			
	Med	13291	15S11/102 TRAY	120	240	Clear-Refrigerator 12-LampTray	137	15 400	C-7A	2 1/4					
	S14	Med	11137	15S14/GR/CL/8	130	120	Clear-Sign, Group Replacement, BB (23)*	90	15 8000	C-9	3 1/2	2 1/2			
			42590	15S14/F/BB	34	120	Frost-Locomotive Cab (23)*	144	15 1000	C-9	3 1/2	2 1/2			
	T6	Cand	13390	15T6	120	60	Clear-Switchboard	107	15 2000	C-7A	3 1/16				
			13402	15T6	145	60	Clear-Switchboard	102	15 2000	C-7A	3 1/16				
			22114	15T6C CARD	145	120	Clear-Switchboard, Blister Card	102	15 2000	C-7A	3 1/16				
	T7	Cand	13494	15T7C	120	120	Clear-Signal Light, Appliance (29, 62)*	108	15 3000	C-7A	2 1/4	1 1/2			
			Inter	35153	15T7N CARD	120	240	Clear-Appliance (29, 62)*	108	15	C-7A	2 1/4	1 9/16		
			DC Bay	35154	15T7DC CARD	120	240	Clear-Appliance 12-Pack (29, 62)*	108	15	C-7A	2 1/4	1 9/16		
	T10	Med	34407	15T10 24PK	120	24	Clear-Aquarium	120	15 2500	C-8	5 5/8				
15-135-150 WATTS															
	A21	3C Med	23068	15/150/SECURITY 12PK	120	60	Security 3-Way, Soft White (25)*	75	15 3000	C-2R CC-8	5 1/4	3 1/8			
								2080	135 1500						
								2155	150 1500						

To save energy costs, find the bulbs with the light output you need, then choose the one with the lowest watts. To convert inches to millimeters, multiply by 25.4. © Means this lamp meets Federal Minimum Efficiency Standards. (*) All footnote references found at the end of this section. ➤ Reduced Wattage



Bulb	Base	Product Code	Lamp Description	Volts	Case Qty.	Additional Information	Lumens	Watts	Life Hours	Filament Design	MOL in.	LCL in.	Color Temp. K	Approx. Beam Spread
------	------	--------------	------------------	-------	-----------	------------------------	--------	-------	------------	-----------------	---------	---------	---------------	---------------------

INCANDESCENT LAMPS

18 WATTS



S11	SC Bay	13655	18S11/1SC	10	120	Clear-Railway Signal Light (70)*	250	18	2000	CC-6	2 ³ / ₈	1 ¹ / ₄		
		13659	18/3 ¹ / ₂ S11SC	10	120	Clear-Railway Signal Light. C-12 Filament in multiple (70)*	300	18	1000	CC-6	2 ³ / ₈	1 ¹ / ₄		



A15	2-Lug Slv	13644	18/3 ¹ / ₂ A15/5	10	120	Clear-Railway Signal Light CC-6 Filament in multiple, 2-Lug Base (10)*	235	18	1500	CC-6	3 ³ / ₄	2 ⁷ / ₃₂		
	3-Lug Slv	13647	18/3 ¹ / ₂ A15/7	10	120	CC-6, 3-Lug Base, Railway Signal (10)*	235	18	1500	CC-6	3 ³ / ₄	2 ³ / ₁₆		

20-24 WATTS



S11	SC Bay	19549	20S11/1SC	10	120	Railway Signal Light			20 3000	CC-6	2 ³ / ₈	1 ¹ / ₄		
T6 ¹ / ₂	Inter	34272	20T6 ¹ / ₂ /F	120	60	Frost-Exit Light (6)*	90	20	7000	C-8		5 ¹ / ₂		
	DC Bay	34241	20T6 ¹ / ₂ /DC/F	120	60	Frost-Exit Light (6)*	90	20	5000	C-8		5 ¹ / ₁₆		

25 WATTS



A15	Med	44448	25A15/RFL	130	120	Reflector Sign-Light I.F. BB (23)*	150	25	3000	C-9	3 ¹ / ₂	2 ³ / ₈		
-----	-----	-------	-----------	-----	-----	------------------------------------	-----	----	------	-----	-------------------------------	-------------------------------	--	--



A17	Med	13744	25A17/RS	75	120	I.F.-Train. Rough Service (53)*	250	25	1000	C-9	3 ⁵ / ₈	2 ¹ / ₂		
-----	-----	-------	----------	----	-----	---------------------------------	-----	----	------	-----	-------------------------------	-------------------------------	--	--



A19	Med	35613	25A	130	120	Inside Frost	215	25	2500	CC-6	4 ¹ / ₄	2 ¹ / ₂		
-----	-----	-------	-----	-----	-----	--------------	-----	----	------	------	-------------------------------	-------------------------------	--	--



		41272	25A/W 24PK	120	120	Soft White	210	25	2500	CC-6	4 ¹ / ₄	2 ¹ / ₂		
--	--	-------	------------	-----	-----	------------	-----	----	------	------	-------------------------------	-------------------------------	--	--

		13990	25A/CL	120	120	Clear-Decorative	215	25	2500	CC-6	4 ¹ / ₄	2 ¹ / ₂		
--	--	-------	--------	-----	-----	------------------	-----	----	------	------	-------------------------------	-------------------------------	--	--

		15064	25A/CL 24PK	120	120	Clear	215	25	2500	CC-6	4 ¹ / ₄	2 ¹ / ₂		
--	--	-------	-------------	-----	-----	-------	-----	----	------	------	-------------------------------	-------------------------------	--	--

		13992	25A/CL	130	120	Clear	215	25	2500	CC-6	4 ¹ / ₄	2 ¹ / ₂		
--	--	-------	--------	-----	-----	-------	-----	----	------	------	-------------------------------	-------------------------------	--	--

		33486	25A/RS 24PK	120	24	I.F.-Rough Service (95)*	190	25	1000	C-17	3 ⁷ / ₈	2 ⁹ / ₁₆		
--	--	-------	-------------	-----	----	--------------------------	-----	----	------	------	-------------------------------	--------------------------------	--	--

		14293	25A19/GR/CL	130	120	Clear-Sign, Group Replacement, BB (23)*	190	25	3000	C-9	3 ⁷ / ₈	2 ³ / ₈		
--	--	-------	-------------	-----	-----	---	-----	----	------	-----	-------------------------------	-------------------------------	--	--

		19316	25A/GR/CL/8	130	120	Clear-Long Life Sign, BB (23)*	120	25	8000	C-9	3 ⁷ / ₈	2 ³ / ₈		
--	--	-------	-------------	-----	-----	--------------------------------	-----	----	------	-----	-------------------------------	-------------------------------	--	--

		37577	25A/B 24PK	120	24	Blue, BB (23)*		25	2500	C-9	3 ⁷ / ₈			
--	--	-------	------------	-----	----	----------------	--	----	------	-----	-------------------------------	--	--	--

		37578	25A/G 24PK	120	24	Green, BB (23)*		25	2500	C-9	3 ⁷ / ₈			
--	--	-------	------------	-----	----	-----------------	--	----	------	-----	-------------------------------	--	--	--

		40320	25A/O 24PK	120	24	Orange, BB (23)*		25	2500	C-9	3 ⁷ / ₈			
--	--	-------	------------	-----	----	------------------	--	----	------	-----	-------------------------------	--	--	--

		37579	25A/R 24PK	120	24	Red, BB (23)*		25	2500	C-9	3 ⁷ / ₈			
--	--	-------	------------	-----	----	---------------	--	----	------	-----	-------------------------------	--	--	--

		37793	25A/Y 24PK	120	24	Yellow, BB (23)*		25	2500	C-9	3 ⁷ / ₈			
--	--	-------	------------	-----	----	------------------	--	----	------	-----	-------------------------------	--	--	--

		49724	25A/TB 6PK	120	120	Transp. Blue-Party Light		25	2500	C-9	3 ⁷ / ₈	2 ³ / ₈		
--	--	-------	------------	-----	-----	--------------------------	--	----	------	-----	-------------------------------	-------------------------------	--	--

		49725	25A/TG 6PK	120	120	Transp. Green-Party Light		25	2500	C-9	3 ⁷ / ₈	2 ³ / ₈		
--	--	-------	------------	-----	-----	---------------------------	--	----	------	-----	-------------------------------	-------------------------------	--	--

		22730	25A/TPK 6PK	120	120	Transp. Pink-Party Light		25	2500	C-9	3 ⁷ / ₈	2 ³ / ₈		
--	--	-------	-------------	-----	-----	--------------------------	--	----	------	-----	-------------------------------	-------------------------------	--	--

		22731	25A/TP 6PK	120	120	Transp. Purple-Party Light		25	2500	C-9	3 ⁷ / ₈	2 ³ / ₈		
--	--	-------	------------	-----	-----	----------------------------	--	----	------	-----	-------------------------------	-------------------------------	--	--

		49727	25A/TR 6PK	120	120	Transp. Red-Party Light		25	2500	C-9	3 ⁷ / ₈	2 ³ / ₈		
--	--	-------	------------	-----	-----	-------------------------	--	----	------	-----	-------------------------------	-------------------------------	--	--

		22732	25A/TE 6PK	120	120	Transp. Teal-Party Light		25	2500	C-9	3 ⁷ / ₈	2 ³ / ₈		
--	--	-------	------------	-----	-----	--------------------------	--	----	------	-----	-------------------------------	-------------------------------	--	--

		49728	25A/TY 6PK	120	120	Transp. Yellow-Party Light		25	2500	C-9	3 ⁷ / ₈	2 ³ / ₈		
--	--	-------	------------	-----	-----	----------------------------	--	----	------	-----	-------------------------------	-------------------------------	--	--

		13769	25A	12	120	Inside Frost (53)*	378	25	1000	C-6	3 ⁷ / ₈	2 ⁹ / ₁₆		
--	--	-------	-----	----	-----	--------------------	-----	----	------	-----	-------------------------------	--------------------------------	--	--

		13784	25A	34	120	I.F.-Train (53)*	390	25	1000	C-9	3 ⁷ / ₈	2 ⁹ / ₁₆		
--	--	-------	-----	----	-----	------------------	-----	----	------	-----	-------------------------------	--------------------------------	--	--

		13879	25A	250	120	Inside Frost (53)*	220	25	1000	C-17A	3 ⁷ / ₈	2 ⁹ / ₁₆		
--	--	-------	-----	-----	-----	--------------------	-----	----	------	-------	-------------------------------	--------------------------------	--	--

G16 ¹ / ₂	SC Bay	14483	25G16 ¹ / ₂ /SC	120	60	Clear-Railway Signal Light (69)*	220	25	1000	C-5	3	1 ¹ / ₄		
---------------------------------	--------	-------	---------------------------------------	-----	----	----------------------------------	-----	----	------	-----	---	-------------------------------	--	--













PAR36	Scrw Term	14553	25PAR36	5.5	12	Pin Spot. Filament Shield (15)*	100	25	1000	C-6	2 ³ / ₄		3000	19700	5
-------	-----------	-------	---------	-----	----	---------------------------------	-----	----	------	-----	-------------------------------	--	------	-------	---

		14554	25PAR36/NSP	12	12	Narrow Spot-Filament Shield (15)*	100	25	2000	C-6	2 ³ / ₄			2600	9
--	--	-------	-------------	----	----	-----------------------------------	-----	----	------	-----	-------------------------------	--	--	------	---

		14555	25PAR36/WFL	12	12	Wide Flood-Filament Shield (15)*	100	25	1000	C-6	2 ³ / ₄			360	25x37
--	--	-------	-------------	----	----	----------------------------------	-----	----	------	-----	-------------------------------	--	--	-----	-------



Bulb	Base	Product Code	Lamp Description	Volts	Case Qty.	Additional Information	Lumens	Watts	Life Hours	Filament Design	MOL in.	LCL in.	Color Temp. K	Approx. CBCP	Approx. Beam Spread
INCANDESCENT LAMPS															
25 WATTS (Continued)															
	PAR36	Scrw Term	14556	25PAR36/VWFL	12	12	Very Wide Flood. Filament Shield (15)*	100	25	2000	C-6	2 3/4		160	55
			14562	25PAR46	5.5	12	Pin Spot. Filament Shield (15)*	140	25	1000	C-6	3 3/4		55000	5.5x4.5
	R14	Inter	39156	25R14N	120	120	Reflector-Light Inside Frost, BB (4, 23)*		25	1500	CC-2V	2 9/16			
			18230	25R14N	130	120	Reflector-Light Inside Frost, BB (4, 23)*		25	1500	CC-2V	2 9/16			
		SC Bay	33405	25R14SC/SP	12	120	Reflector Spot, Light I.F. BB (4, 23)*		25	2000	CC-8	2 5/8			
	S11	Cand	14585	25S11/2C	120	120	Clear-Medical Spot	260	25	500	C-7A	2 1/4	1 7/16		
			14594	25S11/5C	120	120	Reprographic-Frost. Printer	260	25	500	C-7A	2 1/4	1 9/16		
		SC Bay	14575	25S11/4SC	10	120	Clear-Railway Signal Light (70)*	360	25	1000	CC-6	2 3/8	1 1/4		
	T6 1/2	Inter	14639	25T6 1/2	120	60	Clear-Showcase	244	25	1000	C-8	5 1/2			
			15821	25T6 1/2 CARD	120	120	Clear-Showcase	244	25	1000	C-8	5 1/2			
			14641	25T6 1/2	130	60	Clear-Showcase	244	25	1000	C-8	5 1/2			
			14668	25T6 1/2/F	130	60	Frost-Showcase	240	25	1000	C-8	5 1/2			
		DC Bay	14676	25T6 1/2DC	120	60	Clear-Appliance. Scale Illuminator	244	25	1000	C-8	5 9/16			
			14678	25T6 1/2DC	130	60	Clear-Appliance. Scale Illuminator	244	25	1000	C-8	5 9/16			
			14685	25T6 1/2DC/F	130	60	Frost-Appliance. Scale Illuminator	240	25	1000	C-8	5 9/16			
	T7	Inter	14791	25T7N	120	60	Clear-Appliance	195	25	200	C-7A	2 1/4	1 9/16		
			10692	25T7NCARD 6PK	120	240	Clear-Appliance	195	25	200	C-7A	2 1/4	1 9/16		
		DC Bay	14741	25T7DC	120	60	Clear-Appliance	195	25	200	C-7A	2 1/4	1 5/16		
	T8	Cand	14809	25T8C	120	60	Clear-Microwave	195	25	200	C-7A	2 5/8	1 1/2		
	T10	Med	14880	25T10 24PK	120	192	Clear-Showcase	248	25	1000	C-8	5 5/8			
			41313	25T10 CARD	120	120	Clear-Showcase. 12-Pack	248	25	1000	C-8	5 5/8			
			14866	25T10	130	120	Clear-Showcase	248	25	1000	C-8	5 5/8			
			13487	25T10/F CARD	120	120	Frost-Showcase	244	25	1000	C-8	5 5/8			
			14886	25T10 24PK	250	192	Clear-Showcase (53)*	240	25	1000	C-17A	5 5/8			

WATT-MISER® LAMP

27 WATTS



R20	Med	14883	27R20/MI/1 6PK	120	30	I.F. Refl. Accent Lighting	210	27	2000	C-9	3 15/16		270	43
-----	-----	-------	----------------	-----	----	----------------------------	-----	----	------	-----	---------	--	-----	----

INCANDESCENT LAMPS

30 WATTS



A15	Med	14129	30A15	130	120	I.F. Changing Message Sign, BB (23)*	215	30	5000	C-9	3 1/2	2 3/8		
		15291	30A15/CL	130	120	Clear Changing Message Sign, BB (23)*	215	30	5000	C-9	3 1/2	2 3/8		
		19358	30A15/8	130	120	I.F. - Sign, BB (23)*	180	30	8000	C-9	3 1/2	2 3/8		



R20	Med	15003	30R20	120	60	Reflector-Light I.F.	200	30	2000	C-9	3 15/16			
		14891	30R20/1 6PK	120	30	Standard Reflector	200	30	2000	C-9	3 15/16			
		15000	30R20	130	60	Reflector-Light I.F.	200	30	2000	C-9	3 15/16			
		16213	30R20/6	130	60	Reflector-Light I.F. Flashing Message Sign, BB (23, 76)*	150	30	6000	C-9	3 15/16			



S11	DC Bay	15012	30S11DC	75	120	Clear-Train Marker Control, BDTH (76)*	350	30	500	C-7A	2 3/8	1 1/4		
-----	--------	-------	---------	----	-----	--	-----	----	-----	------	-------	-------	--	--

To save energy costs, find the bulbs with the light output you need, then choose the one with the lowest watts. To convert inches to millimeters, multiply by 25.4. * Means this lamp meets Federal Minimum Efficiency Standards. {} * All footnote references found at the end of this section. ➤ Reduced Wattage



Bulb	Base	Product Code	Lamp Description	Volts	Case Qty.	Additional Information	Lumens	Watts	Life Hours	Life Filament Design	MOL in.	LCL in.	Color Temp. K	Approx. Beam Spread
------	------	--------------	------------------	-------	-----------	------------------------	--------	-------	------------	----------------------	---------	---------	---------------	---------------------

INCANDESCENT LAMPS

30 WATTS (Continued)



S11	DC Bay	17948	30S11DC/RS	75	120	Clear-Train	300	30	2000	C-9	2 3/8	1 1/4		
T8	Disc	15029	L30	120	24	Clear-Lumiline	230	30	1500	C-8	17 3/4			
		15071	L30/W	120	24	White-Lumiline	210	30	1500	C-8	17 3/4			

30-70-100 WATTS



A21	3C Med	41273	30/100 12PK	120	60	Soft White. 3-Way (25)*	305	30	2500	C-2R CC-8	5 1/4	3 7/8		
							995	70	1500					
							1300	100	1500					

33 WATTS



A19	Med	42626	33A19/5	130	120	Clear-Changing Message Sign. Group Replacement, BB (23)*	270	33	2500	C-9	3 7/8			
		21001	33A19/5/V	130	120	Clear-Changing Message Sign. Group Replacement, BB, Vacuum (23)*	270	33	2500	C-9	3 7/8			

WATT-MISER® AND WATT-MISER® PLUS LAMPS

34 WATTS



A19	Med	12612	➔ 40A/34WM	120	120	Watt-Miser®-Diffuse Coating	380	34	2000	CC-6	4 7/16	3 1/8		
		12620	➔ 40A/34WM	130	120	Watt-Miser®-Diffuse Coating Ratings @ 120 volts.	365	34	2000	CC-6	4 7/16	3 1/8		
							270	30	5400					
		13010	➔ 40A/34WMP/99	120	120	Watt-Miser® Plus-Diffuse Coating. LongLife, BB (23)*	375	34	2500	CC-6	4 7/16	3 1/8		
		13009	➔ 40A/34WMP/99	130	120	Watt-Miser® Plus-Diffuse Coating. LongLife, BB (23)* Ratings @ 120 volts.	360	34	2500	CC-6	4 7/16	3 1/8		
							265	30	6800					

INCANDESCENT LAMPS

40 WATTS



A15	Med	15199	40A15	120	120	Clear-Appliance and Oven Service. Vibration Resistant (2)*	435	40	1500	C-9	3 1/2	2 3/8		
		27451	40A15/F 120PK	120	120	Frosted-Appliance and Oven Service. Vibration Resistant. (2)*	355	40	1500	C-9	3 1/2	2 3/8		
		15206	40A15/CD 12PK	120	60	Clear-Appliance and Oven Service. Vibration Resistant (2)*	435	40	1500	C-9	3 1/2	2 3/8		
		21188	40A15 CD/2	120	60	Clear-Appliance and Oven Service. Vibration Resistant (2, 9)*	435	40	1500	C-9	3 1/2	2 3/8		
		20451	40A15/CF CD/2	120	60	Clear-Ceiling Fan. Vibration Resistant (9)*	435	40	1500	C-9	3 1/2	2 3/8		
		27495	40A15/F/CD	120	60	Frosted-Appliance and Oven Service. Vibration Resistant. (2)*	355	40	1500	C-9	3 1/2	2 3/8		
		20452	40A15/W/CF CD/2	120	60	White-Ceiling Fan. Vibration Resistant (9)*	355	40	1500	C-9	3 1/2	2 3/8		



A19	Med	13255	40A 48PK	120	144	Standard	505	40	1000	CC-6	4 7/16	3 1/8		
		34034	40A	130	120	Inside Frost Ratings @ 120 volts.	495	40	1000	CC-6	4 7/16	3 1/8		
							365	36	2600					
		12311	40A/CL 24PK	120	120	Crystal	470	40	1500	CC-6	4 7/16	3 1/8		
		34125	40A/CL	130	120	Clear Ratings @ 120 volts.	470	40	1500	CC-6	4 7/16	3 1/8		
							345	36	4000					
		13257	40A/W 48PK	120	144	Soft White	490	40	1000	CC-6	4 7/16	3 1/8		
		40323	40A/S-130V-24PK	130	24	Survivor™ LongLife, I.F., Vibration Resistant, BB (23)* Ratings @ 120 volts.	360	40	3000	C-9	4 7/16	3 1/8		
							265	36	8300					



A21	Med	15554	40A/TS	130	120	Clear-Traffic Signal, BDTH, BB (23, 76)*	380	40	2000	C-9	4 3/8	2 7/16		
-----	-----	-------	--------	-----	-----	--	-----	----	------	-----	-------	--------	--	--

To save energy costs, find the bulbs with the light output you need, then choose the one with the lowest watts. To convert inches to millimeters, multiply by 25.4.
 © Means this lamp meets Federal Minimum Efficiency Standards. () * All footnote references found at the end of this section. ➔ Reduced Wattage



Bulb	Base	Product Code	Lamp Description	Volts	Case Qty.	Additional Information	Lumens	Watts	Life Hours	Filament Design	MOL in.	LCL in.	Color Temp. K	Approx. Beam Spread
------	------	--------------	------------------	-------	-----------	------------------------	--------	-------	------------	-----------------	---------	---------	---------------	---------------------

INCANDESCENT LAMPS

40 WATTS (Continued)

	R14	Inter	25777	40R14/N/CD	120	30	Indoor Accent Lighting	40	1500	CC-2V	2 11/16					
		Med	25776	40R14/CD	120	30	Indoor Accent Lighting	40	1500	CC-2V	2 3/16					
	R16	Med	25781	40R16/CD	120	30	Indoor Spotlight	40	1500	CC-6	3 3/8					
	S11	Inter	35156	40S11N/1/CD 12PK	120	240	Clear-12-Card Pack (14, 102)*	440	40	500	C-9	2 5/16	1 5/8			
			15734	40S11N/1/F	120	120	Frost (14)*	440	40	500	C-9	2 5/16	1 5/8			
	T6 1/2	Inter	15740	40T6 1/2/2	120	60	Clear-Refrigerator	420	40	750	C-8	5 1/2				
			41312	40T6 1/2/2 CARD	120	120	Clear-Refrigerator	420	40	750	C-8	5 1/2				
			15742	40T6 1/2/2F	120	60	Frost-Appliance	420	40	750	C-8	5 1/2				
	T8	Disc	15804	L40	120	24	Clear-Lumiline	325	40	1500	C-8	11 3/4				
			15839	L40/W	120	12	White-Lumiline	295	40	1500	C-8	11 3/4				
	T8	Med	15754	40T8	120	24	Clear-Showcase	430	40	1000	C-23	11 3/4				
			T10	Med	15852	40T10	120	120	Clear-Showcase	420	40	1000	C-8	5 5/8		
					13489	40T10 CARD	120	120	Clear-Showcase	420	40	1000	C-8	5 5/8		
					15854	40T10	130	120	Clear-Showcase	420	40	1000	C-8	5 5/8		
					15892	40T10/F	120	120	Frost-Showcase	415	40	1000	C-8	5 5/8		
					41314	40T10/F CARD	120	120	Frost-Showcase	415	40	1000	C-8	5 5/8		







45 WATTS

	R20	Med	14878	➔ 45R20/MI/1 6PK	120	30	Reflector Light I.F. Spot (4, 35, 56)*	440	45	2000	C-9	3 5/16		530 43
			18279	➔ 45R20/TWIN	120	30	Reflector Light I.F. Spot - Twin Pk. (4, 35, 56)*	440	45	2000	C-9	3 5/16		530 43
	BR30	Med	20330	➔ 45R/FL/MI/1 6PK	120	30	Reflector Flood (4, 35, 56)*	485	45	2000	CC-6	5 3/8		300
			26804	➔ 45R30/FL/LL	120	30	Reflector Flood - Long Life (4, 35, 56)*	450	45	2500	CC-6	5 3/8		

50 WATTS

	A19	Med	33495	50A/RS 24PK	120	24	I.F.-Rough Service (95)*	490	50	1000	C-17A	3 7/8	2 9/16		
			33497	50A/RS 24PK	130	24	I.F.-Rough Service (95)* Ratings @ 120 volts.	480	50	1000	C-17A	3 7/8	2 9/16		
				14727	50A/RS/CVG 24PK	120	24	Inside Frost-COV-R-GUARD™ Rough Service, BB, Teflon® Coated (23, 47, 83, 95)*	480	50	1000	C-17A	3 7/8	2 9/16	
				16201	50A19/RS	75	120	I.F.-Rough Service, Train (53, 95)*	545	50	1000	C-9	3 7/8	2 1/2	
				40261	50A19/RS/LG	75	120	I.F.-Rough Service, Train (53, 95)*	545	50	1000	C-9	4 7/16	3 1/8	
				15995	50A	250	120	Inside Frost	490	50	1000	C-17A	3 7/8	2 9/16	
	A21	Med		16147	50A/RS	250	120	I.F.-Rough Service (95)*	470	50	1000	C-22	3 7/8	2 9/16	
				16317	50A19	300	120	Inside Frost	460	50	1000	C-17A	3 7/8	2 9/16	
				16366	50A21	12	120	Inside Frost (53)*	875	50	1000	C-6	4 7/8	3 7/16	
				10686	50A21/RV 6PK	12	48	Recreational Vehicle and Marine - Inside Frost (53)*	875	50	1000	C-6	4 7/8	3 7/16	
				16385	50A21	30	120	I.F.-Train (53)*	805	50	1000	C-9	4 7/8	3 7/16	
				16390	50A21	34	120	I.F.-Train (53)*	805	50	1000	C-9	4 7/8	3 7/16	
	R20	Med	16693	50R20	120	60	Reflector-I.F. (4, 35, 56)*	410	50	2000	C-9	3 15/16		510	
			14896	50R20/1 6PK	120	30	Reflector-I.F. (4, 35, 56)*	410	50	2000	C-9	3 15/16		510	
			20368	50R20/TWIN	120	30	Reflector Twin Pk. (4, 35, 56)*	410	50	2000	C-9	3 15/16		510	
			16692	50R20	130	60	Reflector-I.F. (4, 35, 56)*	410	50	2000	C-9	3 15/16		510	
			22977	50R20/PRO 6PK	130	30	Reflector Pro-Line Pack (4, 35, 56)*	410	50	2000	C-9	3 15/16		510	



Bulb	Base	Product Code	Lamp Description	Volts	Case Qty.	Additional Information	Lumens	Watts	Life Hours	Filament Design	MOL in.	LCL in.	Color Temp. K	Approx. Beam Spread	
INCANDESCENT LAMPS															
50 WATTS (Continued)															
	R20	Med	12667	50R20/6	130	60	Reflector-Light I.F. (4, 35, 56)*	400	50	6000	C-9	3 15/16		420	45
			22752	50R20/BLB 6PK	120	6	Blacklight Reflector (4, 35, 56, 103)*		50	1000	C-9	3 15/16			
			20821	50R20/NEO 6PK	120	30	Neodymium - Enrich™ Reflector (4, 35, 56)*		50	2000	C-9	3 15/16			
			16698	50R20/PK	120	60	Reflector-Pink (4, 35, 56)*	200	50	2000	C-9	3 15/16			
			15287	50R20/PK	130	60	Reflector-Pink (4, 35, 56)*		50	2000	C-9	3 15/16			
			14888	50R20/PL/1 6PK	120	30	Reflector Plant Light (4, 35, 56)*		50	2000	C-9	3 15/16			
			14885	50R20/SW/1 6PK	120	30	Reflector Soft-White (4, 35, 56)*	380	50	2000	C-9	3 15/16			
	ER30	Med	44429	50ER30	120	24	ER-Elliptical Reflector, Light I.F. (4, 35, 56)*	525	50	2000	CC-6	6 1/4		690	
			11823	50ER30	130	24	ER-Elliptical Reflector, Light I.F. (4, 35, 56)*	525	50	2000	CC-6	6 1/4		690	
			47878	50ER30/PK	120	24	ER-Elliptical Reflector-Pink (4, 35, 56)*	480	50	2000	CC-6	6 1/4			
	PAR36	Scrw Term	12892	50PAR36VNSP	12	12	Very Narrow Spot, Filament Shield (15)*	200	50	2000	C-6	2 3/4		19000	6
			16540	50PAR36NSP	12	12	Narrow Spot, Filament Shield (15)*	200	50	2000	C-6	2 3/4		11000	10
			16541	50PAR36WFL	12	12	Wide Flood, Filament Shield (15)*	200	50	2000	C-6	2 3/4		900	39x27
			11468	50PAR36WFL/4	12	12	Wide Flood, Filament Shield (15)*	200	50	4000	C-6	2 3/4		720	37x27
			16542	50PAR36VWFL	12	12	Very Wide Flood, Filament Shield (15)*	200	50	2000	C-6	2 3/4		240	55
50-50 WATTS															
	P25d	3C Mog	16535	50/50P25/28	120	60	Clear-2-filament Marine Running Light, BB (1, 23)*	400	50	750	C-5 C-9	5 1/16	3 5/16		
	T12	3C Med	16726	50/50T12	115	24	Clear-2-filament Marine Running Light, BB (23)*	400	50	750	C-5 C9	5 5/16	3		
50-100-150 WATTS															
	A21	3C Med	41280	50/150 12PK	120	60	Soft White, 3-Way (25)*	615 1540 2155	50 100 150	1500 1500 1500	CC-8 CC-8	5 1/4	3 7/8		
			16142	50/150 TWIN/PK	120	24	Soft White, 3-Way, Twin Pack (25)*	615 1540 2155	50 100 150	1500 1500 1500	CC-8 CC-8	5 1/4	3 7/8		
			20810	50/150/NEO 12PK	120	60	Neodymium - Enrich™ 3-Way (25, 104)*		50 100 150	1500 1500 1500	CC-8 CC-8	5 1/4	3 7/8		
			14057	50/150/SSW 12PK	120	60	Super Soft White, 3-Way (25)*	650 1550 2200	50 100 150	1500 1500 1500	CC-8 CC-8	5 1/4	3 7/8		
			22886	50/150A/RL/SW 6PK	120	30	Soft White-Reader Light™ 3-Way (4, 25)*	550 1580 2220	50 100 150	1000 1200 1200	CC-8 C-2R	5 1/4	3 7/8		
50-200-250 WATTS															
	A21	3C Med	19445	50/250/1 12PK	120	60	Soft White, 3-Way (25, 104, 105)*	620 3335 3955	50 200 250	1500 1500 1500	CC-8 CC-25	5 1/4	3 7/8		

To save energy costs, find the bulbs with the light output you need, then choose the one with the lowest watts. To convert inches to millimeters, multiply by 25.4.
 © Means this lamp meets Federal Minimum Efficiency Standards. (*) * All footnote references found at the end of this section. ⚡ Reduced Wattage



Bulb	Base	Product Code	Lamp Description	Volts	Case Qty.	Additional Information	Lumens	Watts	Life Hours	Filament Design	MOL in.	LCL in.	Color Temp. K	Approx. Beam Spread
WATT-MISER® AND WATT-MISER® PLUS LAMPS														
52 WATTS														
	A19	Med	12615 → 60A/52WM	120	120	Watt-Miser®-Diffuse Coating	730	52	1330	CC-8	4 7/16	3 1/8		
			12623 → 60A/52WM	130	120	Watt-Miser®-Diffuse Coating Ratings @ 120 volts.	710	52	1330	CC-8	4 7/16	3 1/8		
			22373 → 52A/WM/COMM	130	24	Watt-Miser® Inside Frost Ratings @ 120 volts.	530	46	3500	CC-8	4 7/16	3 1/8		
			13554 → 60A/52WM/CL	120	120	Watt-Miser®-Clear	740	52	1330	CC-8	4 7/16	3 1/8		
			13555 → 60A/52WM/CL	130	120	Watt-Miser®-Clear Ratings @ 120 volts.	720	52	1330	CC-8	4 7/16	3 1/8		
			13011 → 60A/52WMP/99	120	120	Watt-Miser® Plus, Diffuse Coating, LongLife, BB (23)*	670	52	2500	CC-8	4 7/16	3 1/8		
			13012 → 60A/52WMP/99	130	120	Watt-Miser® Plus, Diffuse Coating, LongLife, BB (23)* Ratings @ 120 volts.	640	52	2500	CC-8	4 7/16	3 1/8		
						480	46	6800						
54 WATTS														
	A21	Med	17960 → 60A21/54WM/TS	120/5	120	Watt-Miser®, Clear-Traffic Signal, Burn BDTH, BB, Krypton (23, 76)*	530	54	8000	C-11V	4 3/8	2 7/16		
			17961 → 60A21/54WM/TS	125/0	120	Watt-Miser®, Clear-Traffic Signal, Burn BDTH, BB, Krypton (23, 76)*	530	54	8000	C-11V	4 3/8	2 7/16		
55 WATTS														
	A19	Med	11904 → 55A/SW/MI 48PK	120	144	Soft White, Miser®	800	55	1000	CC-8	4 7/16	3 1/8		
60 WATTS														
	A21	Med	17968 → 69A21/60WM/TS	120/5	120	Watt-Miser®-Clear, Traffic Signal, Burn BDTH, BB (23, 76)*	610	60	8000	C-11V	4 3/8	2 7/16		
			17969 → 69A21/60WM/TS	125/0	120	Watt-Miser®-Clear, Traffic Signal, Burn BDTH, BB (23, 76)*	610	60	8000	C-11V	4 3/8	2 7/16		
INCANDESCENT LAMPS														
60 WATTS														
	A15	Med	17759 60A15/CF CD/2	120	60	Clear-Ceiling Fan and Appliance, Vibration Resistant (9)*	650	60	1500	C-9	3 1/2	2 3/8		
			14029 60A15/W/CF CD/2	120	60	White, Ceiling-Fan, Vibration-Resistant (9)*	650	60	1500	C-9	3 1/2	2 3/8		
	A19	Med	41026 60A 48PK	120	144	Standard	865	60	1000	CC-6	4 7/16	3 1/8		
			16783 60A	130	120	Inside Frost Ratings @ 120 volts.	850	60	1000	CC-6	4 7/16	3 1/8		
			25905 60A/BLB 6PK	120	30	Black Light (103)*	640	53	2600					
			22361 60A/COMM	120	24	Inside Frost	60	1000	C-9	4 7/16				
			39322 60A/CL 24PK	120	120	Clear	855	60	1000	CC-6	4 7/16	3 1/8		
			41028 60A/W 48PK	120	144	Soft White	870	60	1000	CC-6	4 7/16	3 1/8		
			11947 60A/W/STG 24PK	120	24	Soft White Saf-T-Gard™ (47, 83, 95)*	840	60	1000	CC-6	4 7/16	3 1/8		
			41285 60A/W/LL 24PK	120	120	Soft White-LongLife	812	60	1000	CC-6	4 7/16	3 1/8		
			22384 60A/GD	120	120	Light I.F.-Garage Door, Vibration Resistant	820	60	1500	CC-6	4 7/16	3 1/8		
			23097 60A/GD CARD	120	24	Light I.F. Garage Door, Vibration Resistant, Carded	635	60	3000	C-9	4 7/16	3 1/8		
			14414 60A/CVG 24PK	120	24	Inside Frost-COV-R-GUARD™, BB, Teflon® Coated (23, 47, 83, 95)*	635	60	3000	C-9	4 7/16	3 1/8		
		22972 60A/PRO 24PK	130	24	Pro-Line Pack Ratings @ 120 volts.	850	60	1000	CC-6	4 7/16	3 1/8			
						640	53	2600						



INCANDESCENT LAMPS

60 WATTS (Continued)

Bulb	Base	Product Code	Lamp Description	Volts	Case Qty.	Additional Information	Lumens	Watts	Life Hours	Filament Design	MOL in.	LCL in.	Color Temp. K	Approx. CBCP	Approx. Beam Spread
	Med	40324	60A/S-120V-24PK	120	24	Survivor™ LongLife I.F., Vibration Resistant, BB (23)*	635	60	3000	C-9	4 ⁷ / ₁₆	3 ¹ / ₈			
		40325	60A/S-130V-24PK	130	24	Survivor™ LongLife I.F., Vibration Resistant, BB (23)* Ratings @ 120 volts.	625	60	3000	C-9	4 ⁷ / ₁₆	3 ¹ / ₈			
		14052	60A/SSW 24PK	120	120	Super Soft - Soft White	840	60	1000	CC-8	4 ⁷ / ₁₆	3 ¹ / ₈			
		16882	60A/D	120	120	I.F.-Daylight	290	60	1000	CC-6	4 ⁷ / ₁₆	3 ¹ / ₈			
		20768	60A/NEO 24PK	120	120	Neodymium - Enrich™		60	1000	CC-8	4 ⁷ / ₁₆	3 ¹ / ₈			
		20326	60A/SPK 24PK	120	120	Soft Pink (46)*	675	60	1000	CC-6	4 ⁷ / ₁₆	3 ¹ / ₈			
		41284	60A/Y 24PK	120	120	House Garden™ - Yellow Bug-Lite	550	60	1000	CC-6	4 ⁷ / ₁₆	3 ¹ / ₈			
		16913	60A/SBIF	120	120	I.F.-Silvered Bowl (28)*	740	60	1000	CC-6	4 ⁷ / ₁₆	3 ¹ / ₈			
		41624	60A/PL 6PK	120	24	Plant Light, BB (4, 23)*	630	60	1000	CC-6	4 ⁷ / ₁₆	3 ¹ / ₈			
		16997	60A21/B	120	120	Blue (46)*		60	1000	C-9	4 ⁷ / ₁₆				
		17027	60A21/R	120	120	Red (46)*		60	1000	C-9	4 ⁷ / ₁₆				
		17122	60A21	230	120	Inside Frost (53)*	585	60	1000	C-17A	4 ³ / ₁₆	2 ³ / ₄			
PAR46	Scrw Term	17212	60PAR/2/R	38	12	Red Lens-Train Warning (15, 71)*		60	800	CC-2V	3 ³ / ₄				
T8	Disc	17226	L60	120	24	Clear-Lumiline	480	60	1500	C-8	17 ³ / ₄				
		17266	L60/W	120	12	White-Lumiline	450	60	1500	C-8	17 ³ / ₄				
T10	Med	17292	60T10/64 24PK	120	192	Clear-Showcase, BDTH (76)*	740	60	1000	C-8	5 ⁵ / ₈				
		10698	60T10/CARD 6PK	120	120	Clear - Showcase, BDTH (76)*	740	60	1000	C-8	5 ⁵ / ₈				
		17804	60T10/F/CD	120	120	Frost-Showcase, BDTH (76)*	740	60	1000	C-8	5 ⁵ / ₈				

WATT-MISER® AND WATT-MISER® PLUS LAMPS

65 WATTS

	Med Sid Pr	12847	➤	75PAR/3SP/65WWM	120	12	Compact Spot (15, 56, 96)*	675	65	2000	CC-6	4 ⁵ / ₁₆	2675	5900	14
		12846	➤	75PAR/3FL/65WWM	120	12	Compact Flood (15, 56, 96)*	675	65	2000	CC-6	4 ⁵ / ₁₆	2675	1750	30
	Med	15711	➤	75R30/SP/65WWM	120	24	Reflector Spot (4, 35, 56)*	755	65	2000	CC-6	5 ³ / ₈		1600	
		14264	➤	75R30/SP/65WWM	130	24	Reflector Spot (4, 35, 56)*	725	65	2000	CC-6	5 ³ / ₈			
		15709	➤	75R30/FL/65WWM	120	24	Reflector Flood (4, 35, 56)*	755	65	2000	CC-6	5 ³ / ₈		510	
		14263	➤	75R30/FL/65WWM	130	24	Reflector Flood (4, 35, 56)*	725	65	2000	CC-6	5 ³ / ₈			
		25211	➤	75R30/65WWM/PK	130	24	Reflector - Pink (4, 35, 56)*		65	2000	CC-6	5 ³ / ₈			
		26640	➤	75R30/FL/65WWM/A	120	30	Reflector - Amber (4, 35, 56)*		65	2000	CC-6	5 ³ / ₈			
		26641	➤	75R30/FL/65WWM/B	120	30	Reflector - Blue (4, 35, 56)*		65	2000	CC-6	5 ³ / ₈			
		26642	➤	75R30/FL/65WWM/G	120	30	Reflector - Green (3, 4, 35, 56)*		65	2000	CC-6	5 ³ / ₈			
		26803	➤	75R30/FL/65WWM/PK	120	30	Reflector - Pink (3, 4, 35, 56)*		65	2000	CC-6	5 ³ / ₈			
		26645	➤	75R30/FL/65WWM/Y	120	30	Reflector - Yellow (3, 4, 35, 56)*		65	2000	CC-6	5 ³ / ₈			
		26639	➤	75R30/FL/65WWM/CVG	120	24	Reflector - Cov-R-Guard™ (3, 23, 47, 83, 95)*		65	2000	CC-6	5 ³ / ₈			
		20332	➤	65R/SP/MI/1 6PK	120	30	Reflector Spot (3, 4, 35, 56)*	755	65	2000	CC-6	5 ³ / ₈			
20331	➤	65R/FL/MI/1 6PK	120	30	Reflector Flood (3, 4, 35, 56)*	755	65	2000	CC-6	5 ³ / ₈					
18011	➤	65R/FL/MI/TWIN	120	6	Reflector Flood Twin Pack (3, 4, 35, 56)*	755	65	2000	CC-6	5 ³ / ₈					
23520	➤	65R30/SW 6PK	120	30	Reflector-Soft White (3, 4, 35, 56)*	740	65	2000	CC-6	5 ³ / ₈					
20996	➤	65R30/PL/1 6PK	120	30	Reflector Spot-Plant Light, BB (3, 4, 23, 35, 56)*		65	2000	CC-6	5 ³ / ₈					



Bulb	Base	Product Code	Lamp Description	Volts	Case Qty.	Additional Information	Lumens	Watts	Life Hours	Filament Design	MOL in.	LCL in.	Color Temp. K	Approx. Beam Spread
------	------	--------------	------------------	-------	-----------	------------------------	--------	-------	------------	-----------------	---------	---------	---------------	---------------------

WATT-MISER® AND WATT-MISER® PLUS LAMPS

65 WATTS (Continued)



BR30	Med	22978	➤ 65R30/PRO 6PK	130	30	Reflector Pro-Line Pack (3, 4, 35, 56)*	725	65	2000	CC-6	5 3/8			
------	-----	-------	-----------------	-----	----	---	-----	----	------	------	-------	--	--	--

		22714	➤ 65R30/FL/COMM 12PK	120	12	Watt-Miser® reflector flood (3, 4, 35, 56)*	770	65	2000	CC-6	5 3/8			
--	--	-------	----------------------	-----	----	---	-----	----	------	------	-------	--	--	--



BR40	Med	14265	➤ 75R/FL/65WM	120	24	Watt-Miser®-Reflector Flood I.F. (3, 4, 35, 46, 56)*	730	65	2000	CC-6	6 9/16			
------	-----	-------	---------------	-----	----	--	-----	----	------	------	--------	--	--	--

		14266	➤ 75R/FL/65WM	130	24	Watt-Miser®-Reflector Flood I.F. (3, 4, 35, 46, 56)*	700	65	2000	CC-6	6 9/16			
--	--	-------	---------------	-----	----	--	-----	----	------	------	--------	--	--	--

		14016	➤ 65R40/FL/MI 6PK	120	30	Reflector Flood (3, 4, 35, 46, 56)*	730	65	2000	CC-6	6 9/16			
--	--	-------	-------------------	-----	----	-------------------------------------	-----	----	------	------	--------	--	--	--

INCANDESCENT LAMPS

65 WATTS



BR30	Med	26805	65R30/FL/LL	120	30	Long Life Reflector - Flood (3, 4, 35, 56)*	725	65	2500	CC-6	5 3/8			
------	-----	-------	-------------	-----	----	---	-----	----	------	------	-------	--	--	--

		26806	65R30/SP/LL	120	30	Long Life Reflector - Spot (3, 4, 35, 56)*	725	65	2500	CC-6	5 3/8			
--	--	-------	-------------	-----	----	--	-----	----	------	------	-------	--	--	--

		20822	65R30/NEO 6PK	120	30	Reflector - Neodymium - Enrich™ (3, 4, 35, 56)*	65	2000	CC-6	5 3/8				
--	--	-------	---------------	-----	----	---	----	------	------	-------	--	--	--	--

WATT-MISER® AND WATT-MISER® PLUS LAMPS

67 WATTS



A19	Med	22374	➤ 67A/WM/COMM	130	24	Watt-Miser® Inside Frost Ratings @ 120 volts.	1000 755	67 60	1000 2600	CC-8	4 7/16	3 1/8		
-----	-----	-------	---------------	-----	----	---	-------------	----------	--------------	------	--------	-------	--	--

		12617	➤ 75A/67WM	120	120	Watt-Miser®-Diffuse Coating	1030	67	1000	CC-8	4 7/16	3 1/8		
--	--	-------	------------	-----	-----	-----------------------------	------	----	------	------	--------	-------	--	--

		12624	➤ 75A/67WM	130	120	Watt-Miser®-Diffuse Coating Ratings @ 120 volts.	1000 755	67 60	1000 2600	CC-8	4 7/16	3 1/8		
--	--	-------	------------	-----	-----	--	-------------	----------	--------------	------	--------	-------	--	--

		13013	➤ 75A/67WMP/99	120	120	Watt-Miser® Plus-Diffuse Coating, BB (23)*	940	67	2500	CC-8	4 7/16	3 1/8		
--	--	-------	----------------	-----	-----	--	-----	----	------	------	--------	-------	--	--

		13018	➤ 75A/67WMP/99	130	120	Watt-Miser® Plus-Diffuse Coating, BB (23)* Ratings @ 120 volts.	910 685	67 60	2500 6800	CC-8	4 7/16	3 1/8		
--	--	-------	----------------	-----	-----	---	------------	----------	--------------	------	--------	-------	--	--

INCANDESCENT LAMPS

67 WATTS



A21	Med	38551	67A21/TS	120	120	Clear-Traffic Signal, BDTH, BB (23, 76)*	635	67	8000	C-9	4 3/8	2 7/16		
-----	-----	-------	----------	-----	-----	--	-----	----	------	-----	-------	--------	--	--

		38552	67A21/TS	125	120	Clear-Traffic Signal, BDTH, BB (23, 76)*	635	67	8000	C-9	4 3/8	2 7/16		
--	--	-------	----------	-----	-----	--	-----	----	------	-----	-------	--------	--	--

		38553	67A21/TS	130	120	Clear-Traffic Signal, BDTH, BB (23, 76)*	635	67	8000	C-9	4 3/8	2 7/16		
--	--	-------	----------	-----	-----	--	-----	----	------	-----	-------	--------	--	--

		17323	69A21/TS	120	120	Clear-Traffic Signal, BDTH, BB (23, 76)*	675	69	8000	C-9	4 3/8	2 7/16		
--	--	-------	----------	-----	-----	--	-----	----	------	-----	-------	--------	--	--

		17325	69A21/TS	130	120	Clear-Traffic Signal, BDTH, BB (23, 76)*	675	69	8000	C-9	4 3/8	2 7/16		
--	--	-------	----------	-----	-----	--	-----	----	------	-----	-------	--------	--	--

MISER® LAMPS

70 WATTS



A19	Med	11905	➤ 70A/SW/MI 48PK	120	144	Soft White, Miser®	1125	70	750	CC-8	4 7/16	3 1/8		
-----	-----	-------	------------------	-----	-----	--------------------	------	----	-----	------	--------	-------	--	--

Incandescent



Bulb	Base	Product Code	Lamp Description	Volts	Case Qty.	Additional Information	Lumens	Watts	Life Hours	Filament Design	MOL in.	LCL in.	Color Temp. K	Approx. CSCP	Approx. Beam Spread	
INCANDESCENT LAMPS																
75 WATTS																
	A19	Med	41030	75A 48PK	120	144	Standard	1190	75	750	CC-6	4 ⁷ / ₁₆	3 ¹ / ₈			
			17347	75A	130	120	Inside Frost Ratings @ 120 volts.	1170 885	75 67	750 1950	CC-6	4 ⁷ / ₁₆	3 ¹ / ₈			
			22364	75A/COMM	120	24	Inside Frost	1180	75	750	CC-6	4 ⁷ / ₁₆	3 ¹ / ₈			
			10428	75A/CL 24PK	120	120	Clear	1200	75	750	CC-6	4 ⁷ / ₁₆	3 ¹ / ₈			
			41032	75A/W 48PK	120	144	Soft White	1170	75	750	CC-6	4 ⁷ / ₁₆	3 ¹ / ₈			
			41287	75A/W/LL 24PK	120	120	Soft White-LongLife	1125	75	1125	CC-6	4 ⁷ / ₁₆	3 ¹ / ₈			
			40326	75A/S-120V-24PK	120	24	Survivor™ LongLife I.F., Vibration Resistant, BB (23)*	825	75	3000	C-9	4 ⁷ / ₁₆	3 ¹ / ₈			
			40328	75A/S-130V-24PK	130	24	Survivor™ LongLife I.F. Vibration Resistant, BB (23)* Ratings @ 120 volts.	615	67	8300	C-9	4 ⁷ / ₁₆	3 ¹ / ₈			
	A21	Med	14724	75A/RS/CVG 24PK	120	24	Inside Frost-COV-R-GUARD™ Rough Service, BB, Teflon® Coated (23, 47, 83, 95)*	740	75	1000	C-17		5 ¹ / ₄			
			10696	75A/RT 6PK	120	48	Rough Service, "Ruff-n-Tuff", BB (23, 47, 83, 95)*		75	1000	C-17		5 ¹ / ₄			
			18274	75A/RS 12PK	120	60	I.F. Rough Service (95, 100)*	750	75	1000	C-17		5 ¹ / ₄	3 ¹³ / ₁₆		
			17527	75A/RS 60PK	130	60	I.F. Rough Service (95, 100)* Ratings @ 120 volts.	740 560	75 67	1000 2600	C-17		5 ¹ / ₄	3 ¹³ / ₁₆		
			17482	75A21	12	120	Inside Frost (53)*	1500	75	1000	C-6		5 ¹ / ₄	3 ¹³ / ₁₆		
	R20	Med	11320	75R20 6PK	120	60	Reflector Flood, I.F. (3, 4, 35, 56)*	650	75	2000	C-9		3 ¹⁵ / ₁₆			
			R30	Med	22748	75R30/BLB 6PK	120	6	Reflector Black Light (103)*		75	1000	C-9			
	ER30	Med	37044	75ER30	120	24	ER-Elliptical Reflector, Light I.F. (3, 4, 35, 56)*	850	75	2000	CC-6		6 ¹ / ₄		1200	
			42850	75ER30	130	24	ER-Elliptical Reflector., Light I.F. (3, 4, 35, 56)*	850	75	2000	CC-6		6 ¹ / ₄		1200	
	BR38	Med	18045	75PAR/FL/1/COMM 6PK	120	6	Blown PAR	720	75	2000						
			PAR36	Scrw Term	33869	75PAR36/RS	75	12	PAR-Train Warning-Rough Service (15, 23, 95, 100)*	740	75	500	CC-6		2 ³ / ₄	
	PAR38	Med Sid Pr	17682	75PAR/3FL/MINE	120	12	Mine Flood (56, 58, 96, 15)*	765	75	2000	CC-6		4 ⁵ / ₁₆	2725	1750 33	
			17664	75PAR/3SP/MINE	120	12	Mine Spot (56, 58, 96, 15)*	765	75	2000	CC-6		4 ⁵ / ₁₆	2725		
	PAR46	3 Prong	36473	75PAR46/TS	120	12	Traffic Signal (15)*	700	75	6000	CC-6		3 ⁷ / ₈			
			T10	Med	17754	75T10/45	120	24	Clear-Showcase	800	75	1000	C-23		11 ⁷ / ₈	
17749	75T10/1	120			24	Frost-Showcase	800	75	1000	C-23		11 ⁷ / ₈				
80-170-250 WATTS																
	A23	3C Med	15846	80/250A/RL/SW 6PK	120	30	Soft White-Reader Light™ 3-Way (25, 104, 105)*	1000	80	1000	C-2R	CC-8	5 ³ / ₄	4 ⁵ / ₁₆		
								2800	170	1000						
								3800	250	1000						
E27 BASE - EXPORT LAMPS																
80 WATTS																
	PAR38	Skirted (E27)	18178	80PAR/FL/27	220/0	12	Clear Flood (15)*	750	80	2000	CC-6		5 ¹ / ₂	2650	1500 35	
			18179	80PAR/FL/27	240/0	12	Clear Flood (15)*	750	80	2000	CC-6		5 ¹ / ₂	2650	1500 35	
			18180	80PAR/SP/27	220/0	12	Clear Spot (15)*	750	80	2000	CC-6		5 ¹ / ₂	2650	3300 20	
			18181	80PAR/SP/27	240/0	12	Clear Spot (15)*	750	80	2000	CC-6		5 ¹ / ₂	2650	3300 20	
			18661	80PAR/FL/A/27	240/0	12	Silicone Amber Flood (15)*		80	2000	CC-6		5 ¹ / ₂			
			18650	80PAR/FL/B/27	240/0	12	Silicone Blue Flood (15)*		80	2000	CC-6		5 ¹ / ₂			
			18653	80PAR/FL/G/27	240/0	12	Silicone Green Flood (15)*		80	2000	CC-6		5 ¹ / ₂			
			18656	80PAR/FL/R/27	240/0	12	Silicone Red Flood (15)*		80	2000	CC-6		5 ¹ / ₂			
			18658	80PAR/FL/Y/27	240/0	12	Silicone Yellow Flood (15)*		80	2000	CC-6		5 ¹ / ₂			

To save energy costs, find the bulbs with the light output you need, then choose the one with the lowest watts. To convert inches to millimeters, multiply by 25.4.
 © Means this lamp meets Federal Minimum Efficiency Standards. () * All footnote references found at the end of this section. ➤ Reduced Wattage



Bulb	Base	Product Code	Lamp Description	Volts	Case Qty.	Additional Information	Lumens	Watts	Life Hours	Filament Design	MOL in.	LCL in.	Color Temp. K	Approx. CBCP	Beam Spread	
WATT-MISER® PAR LAMPS																
85 WATTS																
	PAR38	Med Skirt	13465 ↗ 100PAR/B/85WM 6PK	120	6	House Garden™ Powder Coated - Blue, BB (15, 23)*	85	2000	2000	CC-6	5 5/16					
			13474 ↗ 100PAR/G/85WM 6PK	120	6	House Garden™ Powder Coated - Green, BB (15, 23)*	85	2000	2000	CC-6	5 5/16					
			13472 ↗ 100PAR/R/85WM 6PK	120	6	House Garden™ Powder Coated - Red, BB (15, 23)*	85	2000	2000	CC-6	5 5/16					
			13473 ↗ 100PAR/Y/85WM 6PK	120	6	House Garden™ Powder Coated - Yellow, BB (15, 23)*	85	2000	2000	CC-6	5 5/16					
INCANDESCENT LAMPS																
85 WATTS																
	PAR38	Med Skirt	20945 85PAR/FL/BG 6PK	120	6	House Garden™ Yellow-Bug-Lite, BB (15, 23)*	85	2000	2000	CC-6	5 5/16					
88 WATTS																
	PAR36	Scrw Term	39817 88PAR36/FL	75	12	Projector-Train Warning. (15)*	810	88	1500	CC-6	2 3/4					
WATT-MISER® AND WATT-MISER® PLUS LAMPS																
90 WATTS																
	A19	Med	12618 ↗ 100A/90WM	120	120	Watt-Miser®-Diffuse Coating	1465	90	1000	CC-8	4 7/16	3 1/8				
			12625 ↗ 100A/90WM	130	120	Watt-Miser®-Diffuse Coating Ratings @ 120 volts.	1440	90	1000	CC-8	4 7/16	3 1/8				
			22375 ↗ 90A/WM/COMM	130	24	Watt-Miser® Inside Frost Ratings @ 120 volts.	1440	90	1000	CC-8	4 7/16	3 1/8				
			13019 ↗ 100A/90WMP/99	120	120	Watt-Miser® Plus-Diffuse Coating. LongLife, BB (23)*	1285	90	2500	CC-8	4 7/16	3 1/8				
			13023 ↗ 100A/90WMP/99	130	120	Watt-Miser® Plus-Diffuse Coating. LongLife, BB (23)* Ratings @ 120 volts.	1260	90	2500	CC-8	4 7/16	3 1/8				
	A21	Med	17972 ↗ 100A21/90WM/TS	125/0	120	Watt-Miser®-Clear. Traffic Signal. Burn BDTH, BB, Krypton (23, 76)*	1040	90	8000	C-11V	4 3/8	2 7/16				
		Med	14267 ↗ 100R/FL/90WM	120	24	Watt-Miser®, Reflector Flood (3, 4, 35, 46, 56)*	1100	90	2000	CC-6	6 9/16					
			14268 ↗ 100R/FL/90WM	130	24	Watt-Miser®, Reflector Flood I.F. (3, 4, 35, 46, 56)*	1050	90	2000	CC-6	6 9/16					
		14017 ↗ 90R40/FL/MI 6PK	120	30	Reflector Flood (3, 4, 35, 46, 56)*	1100	90	2000	CC-6	6 9/16						
MISER® LAMPS																
95 WATTS																
	A19	Med	11906 ↗ 95A/SW/MI 48PK	120	144	Soft White Miser®	1610	95	750	CC-8	4 7/16	3 1/8				
INCANDESCENT LAMPS																
100 WATTS																
	A19	Med	41034 100A 48PK	120	144	Standard	1710	100	750	CC-8	4 7/16	3 1/8				
			17933 100A	130	120	Inside Frost Ratings @ 120 volts.	1680	100	750	CC-8	4 7/16	3 1/8				
			22366 100A/COMM	120	24	Inside Frost	1275	89	1950							
			22366 100A/COMM	120	24	Inside Frost	1690	100	750	CC-8	4 7/16	3 1/8				
			22975 100A/PRO 24PK	130	24	Inside Frost Ratings @ 120 volts.	1680	100	750	CC-8	4 7/16	3 1/8				
			1275	89	1950											
		39321 100A/CL 24PK	120	120	Clear	1730	100	750	CC-8	4 7/16	3 1/8					
		41036 100A/W 48PK	120	144	Soft White	1690	100	750	CC-8	4 7/16	3 1/8					



Bulb	Base	Product Code	Lamp Description	Volts	Case Qty.	Additional Information	Lumens	Watts	Life Hours	Filament Design	MOL in.	LCL in.	Color Temp. K	Approx. Beam Spread
------	------	--------------	------------------	-------	-----------	------------------------	--------	-------	------------	-----------------	---------	---------	---------------	---------------------

INCANDESCENT LAMPS

100 WATTS (Continued)



A19	Med	11948	100A/W/STG 24PK	120	24	Soft White Saf-T-Gard™ (47, 83, 95)*	1624	100	750	CC-8	4 ⁷ / ₁₆	3 ¹ / ₈		
		41289	100A/W/LL 24PK	120	120	Soft White-LongLife	1600	100	1125	CC-8	4 ⁷ / ₁₆	3 ¹ / ₈		
		17995	100A/LHT	120	120	Inside Frost, BB, Left-Hand Medium Base (23)*	1710	100	750	CC-6	4 ⁷ / ₁₆	3 ¹ / ₈		
		20773	100A/NEO 24PK	120	120	Neodymium - Enrich™		100	750	CC-8	4 ⁷ / ₁₆	3 ¹ / ₈		
		40329	100A/S-120V-24PK	120	24	Survivor™-I.F., LongLife, Vibration Resistant, BB (23, 46)*	1190	100	3000	C-9	4 ⁷ / ₁₆	3 ¹ / ₈		
		40330	100A/S-130V-24PK	130	24	Survivor™-I.F., LongLife, Vibration Resistant, BB (23, 46)* Ratings @ 120 volts.	1170	100	3000	C-9	4 ⁷ / ₁₆	3 ¹ / ₈		
		14056	100A/SSW 24PK	120	120	Super Soft - Soft White	1690	100	750	CC-8	4 ⁷ / ₁₆	3 ¹ / ₈		
		41291	100A/Y 24PK	120	120	Bug-Lite (14)*	900	100	1000	CC-8	4 ⁷ / ₁₆	3 ¹ / ₈		
		20328	100A/SPK 24PK	120	120	Soft Pink (46)*	1330	100	1000	CC-8	4 ⁷ / ₁₆	3 ¹ / ₈		



A21	Med	18212	100A21	120	60	Inside Frost	1710	100	750	CC-6	5 ¹ / ₄	3 ¹ / ₈		
		18221	100A21	130	60	Inside Frost Ratings @ 120 volts.	1690	100	750	CC-6	5 ¹ / ₄	3 ¹ / ₈		
		21314	100A21/99 60PK	120	60	Diffuse Coating-Extended Service, BB (23)*	1440	100	2500	CC-6	5 ¹ / ₄	3 ¹ / ₈		
		21315	100A21/99 60PK	130	60	Diffuse Coating-Extended Service, BB (23)* Ratings @ 120 volts.	1420	100	2500	CC-6	5 ¹ / ₄	3 ¹ / ₈		
		18275	100A/RS 12PK	120	60	I.F. Rough Service (95, 100)*	1160	100	1000	C-17	5 ¹ / ₄	3 ¹³ / ₁₆		
		17522	100A/RS 60PK	130	60	I.F. Rough Service (95, 100)* Ratings @ 120 volts.	1150	100	1000	C-17	5 ¹ / ₄	3 ¹³ / ₁₆		
		14719	100A/RS/CVG	120	120	I.F.-COV-R-GUARD™ Rough Service, BB, Teflon® Coated (23, 47, 83, 95)*	1230	100	1000	C-17	5 ¹ / ₄	3 ¹³ / ₁₆		
		11245	100A/RT 6PK	120	48	Rough Service - "Ruff-n-Tuff" (23, 47, 83, 95)*		100	1000	C-17	5 ¹ / ₄			
		18365	100A21/TS	130	120	Clear-Traffic Signal. Rated Watts: 98. BDTH, BB (23)*	1280	100	3000	C-9	4 ³ / ₈	2 ⁷ / ₁₆		
		17525	100A21/SBIF 60PK	120	60	I.F. Silvered Bowl (28)*	1400	100	1000	CC-6	5 ¹ / ₄	3 ⁷ / ₈		
		17515	100A 60PK	230	60	Inside Frost (53)*	1280	100	750	C-7A	5 ¹ / ₄	3 ¹³ / ₁₆		
		17516	100A 60PK	250	60	Inside Frost (53)*	1200	100	750	C-7A	5 ¹ / ₄	3 ¹³ / ₁₆		
		17524	100A/RS 60PK	250	60	I.F. Rough Service (53, 95, 100)*	960	100	1000	C-17	5 ¹ / ₄	3 ¹³ / ₁₆		



A23	Med	17904	100A	34	120	I.F.-Train (53)*	2160	100	1000	C-9	5 ¹⁵ / ₁₆	4 ⁷ / ₁₆		
		18512	100A23	12	120	Inside Frost (53)*	1750	100	1000	C-6	5 ¹⁵ / ₁₆	4 ⁷ / ₁₆		
		18542	100A23/20	120	120	Clear-Commercial Oven, BB (3, 23)*	1530	100	1000	CC-6	5 ¹⁵ / ₁₆	4 ⁷ / ₁₆		
		18449	100A23	120	120	Inside Frost	1600	100	750	CC-6	5 ¹⁵ / ₁₆	4 ⁷ / ₁₆		
		33456	100A23/VS 24PK	130	24	I.F.-Vibration Service (12)* Ratings @ 120 volts.	1340	100	1000	C-9	5 ¹⁵ / ₁₆	4 ⁷ / ₁₆		



G16 ¹ / ₂	DC Bay	18721	100G16 ¹ / ₂ /29DC	120	60	Clear-Spot. BDTH, BB (7, 23)*	1660	100	200	CC-13	3	1 ³ / ₈		
PAR38	Med Sid Pr	18822	100PAR38/FL	12	12	PAR-Mine Flood (15, 58)*	1400	100	1000	C-6	4 ⁵ / ₁₆		2200	60



Bulb	Base	Product Code	Lamp Description	Volts	Case Qty.	Additional Information	Lumens	Watts	Life Hours	Filament Design	MOL in.	LCL in.	Color Temp. K	Approx. Beam Spread
E27 BASE - EXPORT LAMPS														
100 WATTS														
	PAR38	Skirted (E27)	38854	100PAR/FL/27	220/0	12	Clear Flood (15)*	800	100	2000	CC-6	5 1/2	2600	1500 35
			40027	100PAR/SP/27	220/0	12	Clear Spot (15)*	800	100	2000	CC-6	5 1/2	2600	3300 20
			42711	100PAR/FL/27	240/0	12	Clear Flood (15)*	800	100	2000	CC-6	5 1/2	2600	1500 35
			42710	100PAR/SP/27	240/0	12	Clear Spot (15)*	800	100	2000	CC-6	5 1/2	2600	3300 20
			40028	100PAR/FL/B/27	220/0	12	Blue Flood (15)*	100	2000	CC-6	5 1/2			
			40029	100PAR/FL/G/27	220/0	12	Green Flood (15)*	100	2000	CC-6	5 1/2			
			40030	100PAR/FL/R/27	220/0	12	Red Flood (15)*	100	2000	CC-6	5 1/2			
			40031	100PAR/FL/Y/27	220/0	12	Yellow Flood (15)*	100	2000	CC-6	5 1/2			
INCANDESCENT LAMPS														
100 WATTS														
	R30	Med	39503	100R30/CL	12	24	Reflector-Clear, Swimming Pool, BB (4, 23, 46, 53)*	1200	100	2000	C-6	5 3/8		
		PAR46	Scrw Term	34465	100PAR46	60	12	Mine Locomotive Headlight (15, 71)*	1290	100	800	CC-2V	3 3/4	
		T8	SC Bay	18881	100T8/1SC	20	24	Clear-Contour Map ANSI: BZA, Source 4.5x3.0 mm (WXH) (8, 31, 61, 94)*	2600	100	50	CC-6	3	2 3/16
100-200-300 WATTS														
	PS25d	3C Mog	18780	100/300/2	120	60	Soft White - 3-Way, Neck of bulb coated red from base to maximum bulb diameter (1, 25, 46)*	1320	100	1500	CC-6	CC-6	6 11/16	4 7/16
								3300	200	1200				
								4620	300	1200				
			41459	100/300 6PK	120	30	Soft White - 3-Way (1, 25, 46)*	1320	100	1500	CC-6	CC-6	6 11/16	4 7/16
								3300	200	1200				
								4620	300	1200				
110 WATTS														
	R30	Med	18980	110R30/FL/RS	120	24	Reflector Flood. I.F. Rough Service, BB (23)*	1080	110	2000	C-17	5 3/8		
116 WATTS														
	A21	Med	19008	116A21/TS	120	120	Clear-Traffic Signal, BDTH (23, 76)*	1280	116	8000	C-9	4 3/8	2 7/16	
								1280	116	8000	C-9	4 3/8	2 7/16	
								1280	116	8000	C-9	4 3/8	2 7/16	
			19009	116A21/TS	125	120	Clear-Traffic Signal, BDTH, BB (23, 76)*	1280	116	8000	C-9	4 3/8	2 7/16	
			19010	116A21/TS	130	120	Clear-Traffic Signal, BDTH, BB (23, 76)*	1280	116	8000	C-9	4 3/8	2 7/16	
120 WATTS														
	ER40	Med	41607	120ER40	120	24	ER-Elliptical Reflector, Light I.F. (3, 4, 35, 46, 56)*	1425	120	2000	CC-6	7 3/8		1700
								1425	120	2000	CC-6	7 3/8		1700
			43231	120ER40	130	24	ER-Elliptical Reflector, Light I.F. (3, 4, 35, 46, 56)*	1425	120	2000	CC-6	7 3/8		1700
WATT-MISER® LAMPS														
120 WATTS														
	PAR38	Med Sid Pr	12810	150PAR/3SP/120WM	120	12	Watt-Miser®-Spot (15, 56, 58, 96)*	1370	120	2000	CC-6	4 5/16	2725	9200 18
								1370	120	2000	CC-6	4 5/16	2725	3600 30
			12808	150PAR/3FL/120WM	120	12	Watt-Miser®-Flood (15, 56, 58, 96)*	1370	120	2000	CC-6	4 5/16	2725	3600 30

Incandescent



Bulb	Base	Product Code	Lamp Description	Volts	Case Qty.	Additional Information	Lumens	Watts	Life Hours	Filament Design	MOL in.	LCL in.	Color Temp. K	Approx. Beam Spread
------	------	--------------	------------------	-------	-----------	------------------------	--------	-------	------------	-----------------	---------	---------	---------------	---------------------

E27 BASE - EXPORT LAMPS

120 WATTS



PAR38	Skirted	18172	➔ 120PAR/FL/27	220/0	12	Clear Flood (15)*	1200	120	2000	CC-6	5 1/2		2675	2300	35
		18173	➔ 120PAR/FL/27	240/0	12	Clear Flood (15)*	1200	120	2000	CC-6	5 1/2		2675	2300	35
		18175	➔ 120PAR/SP/27	220/0	12	Clear Spot (15)*	1200	120	2000	CC-6	5 1/2		2675	5500	20
		18177	➔ 120PAR/SP/27	240/0	12	Clear Spot (15)*	1200	120	2000	CC-6	5 1/2		2675	5500	20



PAR56	Scrw Term	19023	120PAR56VNSP	12	12	Very Narrow Spot (11, 15, 56, 59)*	1050	120	2000	C-6	4 1/2		2750	60000	8x6
		19024	120PAR56/MFL	12	12	Medium Flood (11, 15, 56, 59)*	1050	120	2000	C-6	4 1/2		2750	19000	18x9
		19025	120PAR56/WFL	12	12	Wide Flood (11, 15, 56, 59)*	1050	120	2000	C-6	4 1/2		2750	5625	35x18

WATT-MISER® PLUS LAMPS

120 WATTS



BR40	Med	15048	➔ 150R/FL/120WM	120	24	Watt-Miser®-Reflector Flood I.F. (3, 4, 35, 46, 56)*	1600	120	2000	CC-6	6 9/16				1450
		27429	➔ 150R/FL/120WM/B	120	24	Watt-Miser®-Reflector Flood - Blue (3, 4, 35, 46, 56)*		120	2000	CC-6	6 9/16				1450
		27430	➔ 150R/FL/120WM/BW	120	24	Watt-Miser®-Reflector Flood - Blue White (3, 4, 35, 46, 56)*		120	2000	CC-6	6 9/16				1450
		15746	➔ 150R/FL/120WM	130	24	Watt-Miser®-Reflector Flood I.F. (3, 4, 35, 46, 56)*	1600	120	2000	CC-6	6 9/16				1450
		27428	➔ 150R/FL/120WM/CVG	130	24	Watt-Miser®-Reflector Flood COV-R-GUARD™ Teflon® Coated (3, 47, 83, 95)*	1550	120	2000	CC-6	6 9/16				1450
		27433	➔ 150R/FL/120WM/PK	120	24	Watt-Miser®-Reflector Flood - Pink (3, 4, 35, 46, 56)*		120	2000	CC-6	6 9/16				1450
		27436	➔ 150R/FL/120WM/TB	120	24	Watt-Miser®-Jewelry Flood-Reflector Flood-Transparent Daylight Blue (3, 4, 35, 46, 56)*		120	1500	CC-6	6 9/16				1450
		15047	➔ 150R/SP/120WM	120	24	Watt-Miser®-Reflector Spot-Light I.F. (3, 4, 35, 46, 56)*	1600	120	2000	CC-6	6 9/16				6700
		22715	➔ 120R/FL/COMM 6PK	120	30	Watt-Miser® Reflector Flood IF (3, 4, 35, 46, 56)*	1600	120	2000	CC-6	6 9/16				
		20333	➔ 120R/FL/MI/1 6PK	120	30	Miser®-Reflector Flood (3, 4, 35, 46, 56)*	1600	120	2000	CC-6	6 9/16				
		20824	➔ 120R/FLMI/TWIN	120	3	Reflector Flood - Twin Pack (3, 4, 35, 46, 56)*	1600	120	2000	CC-6	6 9/16				
		22987	➔ 120R40/PRO 6PK	130	30	Pro-Line Pack - Reflector (3, 4, 35, 46, 56)*	1600	120	2000	CC-6	6 9/16				
		21000	➔ 120R40/PL-1 6PK	120	30	Reflector Plant Light, BB (3, 4, 23, 35, 46, 56)*		150	2000	CC-6	6 9/16				
		20334	➔ 120R/SP/MI/1 6PK	120	30	Reflector Spot (3, 4, 35, 46, 56)*	1600	120	2000	CC-6	6 9/16				

INCANDESCENT LAMPS

125 WATTS



BR40	Med	13049	125R40/1	120	24	Reflector Infrared, Clear (2A, 4, 46, 56, 94)*		125	5000	C-9	6 9/16				
------	-----	-------	----------	-----	----	--	--	-----	------	-----	--------	--	--	--	--

WATT-MISER® AND WATT-MISER® PLUS LAMPS

135 WATTS



A21	Med	12619	➔ 150A/135WM	120	60	Watt-Miser®-Diffuse Coating	2380	135	1000	CC-8	5 3/8	4 1/16			
		12627	➔ 150A/135WM	130	60	Watt-Miser®-Diffuse Coating Ratings @ 120 volts.	2340	135	1000	CC-8	5 3/8	4 1/16			
							1790	120	2600						



Bulb	Base	Product Code	Lamp Description	Volts	Case Qty.	Additional Information	Lumens	Watts	Life Hours	Filament Design	MOL in.	LCL in.	Color Temp. K	Approx. CBCP	Approx. Beam Spread
------	------	--------------	------------------	-------	-----------	------------------------	--------	-------	------------	-----------------	---------	---------	---------------	--------------	---------------------

WATT-MISER® AND WATT-MISER® PLUS LAMPS

135 WATTS (Continued)



A21	Med	13024	➔ 150A/135WMP/99	120	60	Watt-Miser®-Plus-Diffuse Coating, LongLife	2100	135	2500	CC-8	5 ³ / ₈	4 ¹ / ₁₆			
		13025	➔ 150A/135WMP/99	130	60	Watt-Miser®-Plus-Diffuse Coating, LongLife Ratings @ 120 volts.	2060	135	2500	CC-8	5 ³ / ₈	4 ¹ / ₁₆			
		17973	➔ 150A21/135WM/TS	120/5	120	Watt-Miser®-Clear, Traffic Signal, Burn BDTH, BB, Krypton (23, 76)*	1750	135	7000	C-11V	4 ¹ / ₁₆	3			
		17974	➔ 150A21/135WM/TS	125/0	120	Watt-Miser®-Clear, Traffic Signal, Burn BDTH, BB, Krypton (23, 76)*	1750	135	7000	C-11V	4 ¹ / ₁₆	3			

INCANDESCENT LAMPS

150 WATTS



A21	Med	19168	150A	120	60	Inside Frost	2850	150	750	CC-8	5 ³ / ₈	4 ¹ / ₁₆			
		41294	150A 24PK	120	24	Standard	2850	150	750	CC-8	5 ³ / ₈	4 ¹ / ₁₆			
		33009	150A	130	60	Inside Frost Ratings @ 120 volts.	2800	150	750	CC-8	5 ³ / ₈	4 ¹ / ₁₆			
		10429	150A/W 12PK	120	12	Soft White	2780	150	750	CC-8	5 ³ / ₈	4 ¹ / ₁₆			
		16068	150A/CL 12PK	120	12	Clear	2850	150	750	CC-8	5 ³ / ₈	4 ¹ / ₁₆			
		22881	150A/RL/SW 6PK	120	30	Soft White-Reader Light	2650	150	750	CC-8	5 ³ / ₄	4 ⁵ / ₁₆			
		17623	150A21/RS	120	60	I.F.-Rough Service (95, 100)*	2100	150	1000	C-17	5 ¹ / ₄	3 ¹³ / ₁₆			
		17625	150A21/RS	130	60	I.F.-Rough Service (95, 100)* Ratings @ 120 volts.	2065	150	1000	C-17	5 ¹ / ₄	3 ¹³ / ₁₆			
		25926	150A21/99/IF	120	60	I.F.-Extended Service, BB (23)*	2350	150	2500	CC-8	5 ³ / ₈	4 ¹ / ₁₆			
		25929	150A21/99/IF	130	60	I.F.-Extended Service, BB (23)* Ratings @ 120 volts.	2310	150	2500	CC-8	5 ³ / ₈	4 ¹ / ₁₆			
		15817	150A/S	120	60	Survivor™-I.F. LongLife. Vibration Resistant, BB (23, 46)*	1950	150	3000	C-9	4 ¹⁵ / ₁₆	3 ³ / ₈			
		15818	150A/S	130	60	Survivor™-I.F. LongLife. Vibration Resistant, BB (23, 46)* Ratings @ 120 volts.	1925	150	3000	C-9	4 ¹⁵ / ₁₆	3 ³ / ₈			
		22889	150A/GAR 12PK	120	12	I.F. - Garage	2600	150	1125	CC-8	5 ³ / ₈	4 ¹ / ₁₆			
P25	Med	19334	150P25/2SB	120	60	Clear-Spot. Silvered Bowl. Hard glass button, BB (23, 28)*	2100	150	200	C-7A	4 ³ / ₄				
		19372	150P25/10	120	60	Light I.F.-Spot. Hard glass button, BB (23)*	2100	150	200	C-7A	4 ³ / ₄	3			
PAR38	Med Skirt	26370	150PAR/FL/CVG	120	12	COV-R-GUARD™ Flood, BB, Teflon® Coated (23, 47, 83, 95)*	1700	150	2000	CC-6	5 ⁵ / ₁₆				
		26371	150PAR/SP/CVG	120	12	COV-R-GUARD™ Spot, BB, Teflon® Coated (23, 47, 83, 95)*	1700	150	2000	CC-6	5 ⁵ / ₁₆				
		19464	150PAR/FL/A	120	12	Flood. Dichro Amber (15)*	150	2000	CC-6	5 ⁵ / ₁₆					
		19465	150PAR/FL/B	120	12	Flood. Dichro Blue (15)*	150	2000	CC-6	5 ⁵ / ₁₆					
		19467	150PAR/FL/G	120	12	Flood. Dichro Green (15)*	150	2000	CC-6	5 ⁵ / ₁₆					
		19468	150PAR/FL/R	120	12	Flood. Dichro Red (15)*	150	2000	CC-6	5 ⁵ / ₁₆					
	Med Sid Pr	19497	150PAR/4	125	12	Mine-Spot (15, 18, 56, 96)*	1500	150	2000	C-13	4 ⁵ / ₁₆		2775		
		19503	150PAR/3FL/MINE	120	12	Mine-Flood (15, 18, 56, 96)*	1740	150	2000	CC-6	4 ⁵ / ₁₆		2775	3100	36
		19505	150PAR/3FL/MINE	130	12	Mine-Flood (15, 18, 56, 96)*	1740	150	2000	CC-6	4 ⁵ / ₁₆			3100	36
		19487	150PAR/3SP/MINE	120	12	Mine-Spot (15, 18, 56, 96)*	1740	150	2000	CC-6	4 ⁵ / ₁₆			12000	16
		19489	150PAR/3SP/MINE	130	12	Mine-Spot (15, 18, 56, 96)*	1740	150	2000	CC-6	4 ⁵ / ₁₆			12000	16
BR38	Med	18052	150PAR/FL/1/COMM 6PK	120	6	Blown PAR	1650	150	2000						



Incandescent



Bulb	Base	Product Code	Lamp Description	Volts	Case Qty.	Additional Information	Lumens	Watts	Life Hours	Filament Design	MOL in.	LCL in.	Color Temp. K	Approx. Beam Spread
------	------	--------------	------------------	-------	-----------	------------------------	--------	-------	------------	-----------------	---------	---------	---------------	---------------------

E27 BASE - EXPORT LAMPS

150 WATTS



PAR38	Skirted	40033	150PAR/FL/27	220/0	12	Clear Flood (15)*	1350	150	2000	CC-6	5 1/2		2650	2450	35
		40035	150PAR/FL/27	240/0	12	Clear Flood (15)*	1350	150	2000	CC-6	5 1/2		2650	2450	35
		40034	150PAR/SP/27	240/0	12	Clear Spot (15)*	1350	150	2000	CC-6	5 1/2		2650	5600	20
		34725	150PAR38/2FL/27	220/0	12	Cool Beam Clear Flood (15, 78)*	1350	150	2000	CC-6	5 1/2		2650	2450	35

INCANDESCENT LAMPS

150 WATTS



PAR46	Scrw Term	19512	150PAR46/1	32	12	Mine Locomotive Headlight (15, 56)*	1950	150	800	CC-8	3 3/4		100000	9x9	
		19517	150PAR46	125	12	Mine Locomotive Headlight (15)*	1250	150	1000	C-13	3 3/4				
	3 Prong	35327	150PAR46/TS	115	12	Traffic Signal - Burn Horiz. (2, 15)*	1750	150	6000	CC-6	4				
	Med Sid Pr	41968	150PAR46/3MFL	125	12	Medium Flood (4, 11, 56, 58, 96, 15)*	1500	150	2000	CC-13	4		2750	8000	26x13

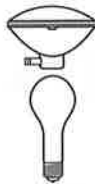

PS25	Med	14635	150PS25/CVG	120	60	Inside Frost-COV-R-GUARD™, BB, Teflon® Coated (23, 47, 83, 95)*	2630	150	1000	C-9	6 15/16				
		19528	150/IF	120	60	Inside Frost	2570	150	750	C-9	6 15/16	5 3/16			
		19530	150/IF	130	60	Inside Frost Ratings @ 120 volts.	2520	150	750	C-9	6 15/16	5 3/16			
		19616	150/RS	120	60	I.F.-Rough Service (95, 100)*	2190	150	1000	C-17	6 15/16	5 3/16			
		19618	150/RS	130	60	I.F.-Rough Service (95, 100)* Ratings @ 120 volts.	2160	150	1000	C-17	6 15/16	5 3/16			
		19597	150/SBIF	120	60	I.F.-Silver Bowl (28)*	2370	150	1000	C-9	6 15/16	5 3/16			
		19656	150/99	120	60	I.F.-Extended Service, BB (23)*	2250	150	2500	C-9	6 15/16	5 3/16			
		19658	150/99	130	60	I.F.-Extended Service, BB (23)* Ratings @ 120 volts.	2200	150	2500	C-9	6 15/16	5 3/16			
		19668	150/99CL	130	60	Clear-Extended Service, BB (23)* Ratings @ 120 volts.	2200	150	2500	C-9	6 15/16	5 3/16			
		33465	150/VS 24PK	130	24	I.F.-Vibration Service Ratings @ 120 volts.	2270	150	1000	C-9	6 15/16	5 3/16			
		14716	150/RS/CVG	120	60	Inside Frost-COV-R-GUARD™ Rough Service, BB, Teflon® Coated (23, 47, 83, 95)*	2120	150	1000	C-17	6 15/16	5 3/16			
PS30	Med	19756	150PS30	230/0	60	Clear-Reflector. Silvered Neck, BB (23, 43, 53)*	1950	150	1000	C-9	8 1/16	6			

175 WATTS



PAR38	Med Skirt	13643	175PAR38/HEAT	120	12	Infrared-Clear (46, 56, 96)*	3100	175	5000	CC-6	5 5/16	4 5/16			
-------	-----------	-------	---------------	-----	----	------------------------------	------	-----	------	------	--------	--------	--	--	--

200 WATTS









A21	Med	11585	200A/W/1 12PK	120	12	Soft White	3910	200	750	CC-8	5 3/8	4 1/16			
		25925	200A21/IF 12PK	120	12	Inside Frost	3920	200	750	CC-8	5 3/8	4 1/16			
		25930	200A21/IF	130	60	Inside Frost Ratings @ 120 volts.	3850	200	750	CC-8	5 3/8	4 1/16			
		16069	200A/CL/1 12PK	120	12	Crystal	3980	200	750	CC-8	5 3/8	4 1/16			
		25932	200A21/CL	130	60	Clear Ratings @ 120 volts.	3850	200	750	CC-8	5 3/8	4 1/16			



Bulb	Base	Product Code	Lamp Description	Volts	Case Qty.	Additional Information	Lumens	Watts	Life Hours	Filament Design	MOL in.	LCL in.	Color Temp. K	Approx. Beam Spread					
INCANDESCENT LAMPS																			
200 WATTS (Continued)																			
	A21	Med	25937	200A21/99/CL	130	60	Clear-Extended Service, BB Ratings @ 120 volts.	3250	200	2500	CC-8	5 3/8	4 1/16						
								2600	177	4500									
								25935	200A21/99/IF	120	60	I.F.-Extended Service, BB	3320	200	2500	CC-8	5 3/8	4 1/16	
			25936	200A21/99/IF	130	60	I.F.-Extended Service, BB Ratings @ 120 volts.	3250	200	2500	CC-8	5 3/8	4 1/16						
							2600	177	4500										
	PAR46	Med Sid Pr	20115	200PAR46/3NSP	120	12	Narrow Spot (4, 11, 15, 36, 56, 58, 96)*	2270	200	2000	CC-13	4	2750	31000 12x8					
								2270	200	2000	CC-13	4	2750	31000 12x8					
								20138	200PAR46/3MFL	120	12	Medium Flood (4, 11, 15, 36, 56, 58, 96)*	2270	200	2000	CC-13	4	2750	11500 27x13
								20140	200PAR46/3MFL	130	12	Medium Flood (4, 11, 15, 36, 56, 58, 96)*	2270	200	2000	CC-13	4	2750	11500 27x13
	PAR56	Scrw Term	20122	200PAR	30	12	Locomotive Headlight (2, 15)*	3700	200	500	CC-8	4 1/2	270000	9x9					
		MogEnd Pr	49889	200PAR56/MFL	120	12	Medium Flood (4, 11, 15, 56, 59)*	2270	200	2000	CC-13	5	2750	15000 22x13					
	PS30	Med	14636	200PS30/CVG	120	60	Inside Frost-COV-R-GUARD™, BB, Teflon® Coated (23, 47, 83, 95)*	3480	200	1000	C-9	8 1/16	6						
								3330	200	1000	C-9	8 1/16	6						
								14637	200PS30/RS/CVG	120	60	Inside Frost-COV-R-GUARD™ Rough Service, BB, Teflon® Coated (23, 47, 83, 95)*	3320	200	1000	C-9	8 1/16	6	
								20403	200PS30/24	130	60	Clear-Rough Service (95, 100)* Ratings @ 120 volts.	3240	200	1000	C-9	8 1/16	6	
													2495	177	2600				
								20316	200/SBIF	120	60	I.F.-Silvered Bowl (28)*	3320	200	1000	C-9	8 1/16	6	
								20354	200/99IF	130	60	I.F.-Extended Service, BB (23)* Ratings @ 120 volts.	3000	200	2500	C-9	8 1/16	6	
													2310	177	6800				
			20172	200	130	60	Clear Ratings @ 120 volts.	3540	200	750	C-9	8 1/16	6						
							2725	177	1950										
			20252	200/IF	130	60	Inside Frost Ratings @ 120 volts.	3540	200	750	C-9	8 1/16	6						
							2725	177	1950										
			33468	200PS30/23 24PK	130	24	I.F.-Rough Service (95, 100)* Ratings @ 120 volts.	3240	200	1000	C-9	8 1/16	6						
							2495	177	2600										
			20192	200	250	60	Clear	2980	200	1000	C-9	8 1/16	6						
240 WATTS																			
	PAR46	Scrw Term	20575	240PAR56/VNSP	12	12	Very Narrow Spot (4, 11, 15, 56, 58)*	2570	240	2000	C-6	4 1/2	2800	140000 9x6					
								2570	240	2000	C-6	4 1/2	2800	46000 19x8					
								20577	240PAR56/WFL	12	12	Wide Flood (4, 11, 15, 56, 58)*	2570	240	2000	C-6	4 1/2	2800	13000 35x18
250 WATTS																			
	A23	Med	15843	250A/RL/SW 6PK	120	30	Soft White-Reader Light™ (1)*	4500	250	750	CC-8	5 3/4	4 5/16						
	R40	Med	37770	250R40/1 6PK	120	30	Reflector-Warm Up Infrared Heat Lamp - Clear Face (2A, 4, 6, 34, 46, 56, 94, 95)*	2200	250	5000	C-9	6 9/16							
								2150	250	5000	C-9	6 9/16							
								16257	250R40/1/CVG	120	24	Clear-COV-R-GUARD™ Teflon® Coated. Food Warming, Reflector-Infrared (4, 6, 46, 47, 56, 83, 94, 95)*	2150	250	5000	C-9	6 9/16		
			37771	250R40/10 6PK	120	30	Reflector-Chill Chaser Infrared Heat Lamp. Red, HRG (2A, 4, 6, 15, 34, 46, 56, 94)*	250	5000	C-9	6 9/16								



Bulb	Base	Product Code	Lamp Description	Volts	Case Qty.	Additional Information	Lumens	Watts	Life Hours	Filament Design	MOL in.	LCL in.	Color Temp. K	Approx. CBCP	Approx. Beam Spread
INCANDESCENT LAMPS															
250 WATTS (Continued)															
	R40	Med Skirt	20724	250R40/4	120	24	Reflector Infrared Industrial-Light I.F., BB (4, 6, 23, 34, 56, 95)*	250	5000	C-9	7 7/16				
300 WATTS															
	PAR46	Scrw Term	23427	300PAR56/WFL	120	12	PAR-Wide Flood. Swimming (4, 15)*	6000	300	1000	C-6	4 1/2			
	PAR56	Mog End Prong (GX16D)	20803	300PAR56/NSP	120	12	Narrow Spot (4, 11, 15, 56, 59)*	3840	300	2000	CC-13	5	2750	68000	10x8
			20836	300PAR56/MFL	120	12	Medium Flood (4, 11, 15, 56, 59)*	3840	300	2000	CC-13	5	2750	24000	23x11
			20838	300PAR56/MFL	130	12	Medium Flood (4, 11, 15, 56, 59)*	3840	300	2000	CC-13	5	2750	24000	23x11
			20849	300PAR56/WFL	120	12	Wide Flood (4, 11, 15, 56, 59)*	3840	300	2000	CC-13	5	2750	11000	37x18
			20851	300PAR56/WFL	130	12	Wide Flood (4, 11, 15, 56, 59)*	3840	300	2000	CC-13	5	2750	11000	37x18
EXPORT PAR LAMPS															
300 WATTS															
	PAR56	GX16DEXT	20853	300PAR56/NSP	230	12	Narrow Spot (11, 15, 36, 56, 59)*	3450	300	2000	CC-13	5			
			18676	300PAR56/NSP	240/0	12	Narrow Spot (11, 15, 36, 56, 59)*	3450	300	2000	CC-13	5			
			20852	300PAR56/MFL	230	12	Medium Flood (11, 15, 36, 56, 59)*	3450	300	2000	CC-13	5			
			18677	300PAR56/MFL	240/0	12	Medium Flood (11, 15, 36, 56, 59)*	3450	300	2000	CC-13	5			
			20854	300PAR56/WFL	230	12	Wide Flood (11, 15, 36, 56, 59)*	3450	300	2000	CC-13	5			
			18678	300PAR56/WFL	240/0	12	Wide Flood (11, 15, 36, 56, 59)*	3450	300	2000	CC-13	5			
INCANDESCENT LAMPS															
300 WATTS															
	PS25	Med	20861	300M	120	60	Clear	6200	300	750	CC-8	6 15/16	5 3/16		
			20863	300M	130	60	Clear Ratings @ 120 volts.	6120	300	750	CC-8	6 15/16	5 3/16		
			25919	300M/IF 6PK	120	30	Inside Frost	4170	266	1950					
			20917	300M/IF	120	30	Inside Frost Ratings @ 120 volts.	6200	300	750	CC-8	6 15/16	5 3/16		
					130	60	Inside Frost Ratings @ 120 volts.	6120	300	750	CC-8	6 15/16	5 3/16		
					4170	266	1950								
	PS30	Med	20887	300M/99	130	60	Clear-Extended Service, BB (23)* Ratings @ 120 volts.	5110	300	2500	C-9	8 1/16	6		
			20894	300M/99/IF	130	60	I.F.-Extended Service, BB (23)* Ratings @ 120 volts.	3935	266	6800					
					5110	300	2500	C-9	8 1/16	6					
					3935	266	6800								
	PS35	Mog	21139	300/SBIF	130	24	I.F.-Silver Bowl. Burn base up (28, 46)*	5410	300	1000	C-9	9 3/8	7		
			21167	300/99	130	24	Clear-Extended Service	5190	300	2500	C-9	9 3/8	7		
			21177	300/99IF	130	24	I.F.-Extended Service, BB (23)*	5190	300	2500	C-9	9 3/8	7		
			21025	300	130	24	Clear	5820	300	1000	C-9	9 3/8	7		
			21079	300/IF	130	24	Inside Frost	5820	300	1000	C-9	9 3/8	7		



Bulb	Base	Product Code	Lamp Description	Volts	Case Qty.	Additional Information	Lumens	Watts	Life Hours	Filament Design	MOL in.	LCL in.	Color Temp. K	Approx. Beam Spread	
INCANDESCENT LAMPS															
300 WATTS (Continued)															
	Med	21213	300R/FL	120	24	Reflector Flood-I.F. HORIZ (4, 35, 46, 56, 73)*	3700	300	2000	CC-2V (HORIZ)	6 ⁹ / ₁₆			002500	
		21215	300R/FL	130	24	Reflector Flood-I.F. HORIZ (4, 35, 46, 56, 73)* Ratings @ 120 volts.	3465	300	2000	CC-2V (HORIZ)	6 ⁹ / ₁₆			002500	
		21229	300R/FL/1	120	24	Reflector Flood-I.F. BB, HRG (15, 23, 35, 46, 56, 73)*	2670	266	5400	CC-2V (HORIZ)	6 ³ / ₄			001900	
		21197	300R/SP	120	24	Reflector Spot-Light I.F. HORIZ (4, 35, 46, 56, 73)*	3700	300	2000	CC-2V (HORIZ)	6 ⁹ / ₁₆			009000	
	Mog	21254	300R/3FL	120	24	Reflector Flood-I.F. BB (4, 15, 23, 33, 73)*	3750	300	2000	CC-2V	7 ¹ / ₄				
		21256	300R/3FL	130	24	Reflector Flood-I.F. BB (4, 15, 23, 33, 73)*	3750	300	2000	CC-2V	7 ¹ / ₄				
		21263	300R/3FL	250	24	Reflector Flood-I.F. BB (4, 15, 23, 33, 73)*	3300	300	2000	C-7A	7 ¹ / ₄				
	T20	Med BiPost	21280	300T20/1	120	12	Inside Frost, HRG (15, 52, 73, 89)*	5500	300	1000	C-13	6 ¹ / ₂	4		
350 WATTS															
	PAR56	Scrw Term	19866	350PAR56/SP	75	12	Ditch Light-Locomotive (4, 15, 59)*	6200	350	500	CC-8	4 ¹ / ₂			
375 WATTS															
	G30	Med Skirt	21329	375G30	115	24	Clear-Infrared. Industrial, BB (4, 6, 23, 46, 56)*		375	5000	C-7A	7 ³ / ₁₆	5		
	R40	Med Skirt	21331	375R40	115	24	Reflector Infrared Industrial-Light I.F. BB (3, 4, 6, 23, 46, 56)*		375	5000	C-9	7 ³ / ₈			
			21334	375R40/1	115	24	Reflector Infrared Industrial-Clear Face, HRG, BB (3, 4, 6, 15, 23, 46, 56)*		375	5000	C-9	7 ¹ / ₂			
			21336	375R40/10	115	24	Reflector Infrared Industrial-Red Bowl, HRG, BB (3, 4, 6, 15, 23, 46, 56)*		375	5000	C-9	7 ¹ / ₂			
400 WATTS															
	G30	Med	21363	400G/FL	120	60	Clear-Flood, BDTH, BB (23, 76)*	6800	400	800	C-5	5 ¹ / ₈	3		
	R40	Med	17542	400R40/FL	120	24	Reflector Flood. Swimming Pool, BB, HRG (15, 23, 35, 36, 93)*	5000	400	2000	CC-2V (HORIZ)	6 ³ / ₄			
500 WATTS															
	G30	Med Skirt	21426	500G30/1	115	60	Infrared. Industrial, BB (2A, 6, 23, 46, 56)*		500	5000	C-7A	7 ¹ / ₈	5		
	PAR64	ExMogEndPR	39406	500PAR64/NSP	120	12	Narrow Spot (4, 11, 15, 56, 59)*	6500	500	2000	CC-13	6		2800 110000 12x7	
			39409	500PAR64/MFL	120	12	Medium Flood (4, 11, 15, 56, 59)*	6500	500	2000	CC-13	6		2800 37000 23x11	
			39412	500PAR64/WFL	120	12	Wide Flood (4, 11, 15, 56, 59)*	6500	500	2000	CC-13	6		2800 13000 42x20	
			MogEndPr	39411	500PAR64/MFL	230	12	Medium Flood (4, 11, 15, 56, 59)*	5500	500	2000	CC-13	6		2700
	PS35	Mog	21530	500	120	24	Clear, BB (23)*	10850	500	1000	CC-8	9 ³ / ₈	7		
			21532	500	130	24	Clear, BB (23)*	10850	500	1000	CC-8	9 ³ / ₈	7		
			21581	500/IF	130	24	Inside Frost, BB (23)*	10850	500	1000	CC-8	9 ³ / ₈	7		



Bulb	Base	Product Code	Lamp Description	Volts	Case Qty.	Additional Information	Lumens	Watts	Life Hours	Filament Design	MOL in.	LCL in.	Color Temp. K	Approx. Beam Spread
------	------	--------------	------------------	-------	-----------	------------------------	--------	-------	------------	-----------------	---------	---------	---------------	---------------------

INCANDESCENT LAMPS

500 WATTS (Continued)

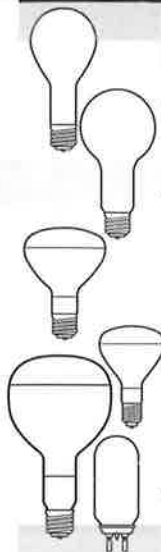

PS35	Mog	21651	500/99/IF	130	24	I.F.-Extended Service, BB (23)*	9070	500	2000	C-9	9 3/4	7		
PS40	Mog	21687	500PS40	120	24	Clear, BB (23)*	9900	500	1000	C-9	9 3/4	7		9900
		21643	500/99	130	24	Clear-Extended Service, BB (23)*	9070	500	2000	C-9	9 3/4	7		
R40	Mog	21734	500R/3FL	120	24	Reflector Flood-I.F. BB, HRG (4, 15, 23, 33, 73)*	6500	500	2000	CC-2V (HORIZ)	7 1/4			
		21736	500R/3FL	130	24	Reflector Flood-I.F. BB, HRG (4, 15, 23, 33, 73)*	6500	500	2000	CC-2V (HORIZ)	7 1/4			
		21744	500R/3FL	250	24	Reflector Flood-I.F. BB, HRG (4, 15, 23, 33, 73)*	6400	500	2000	C-7A	7 1/4			
	Med	41928	500R40/5FL	120	24	Reflector Flood-Swimming Pool, BB, HRG (15, 23, 35, 36, 93)*	6500	500	2000	CC-2V (HORIZ)	6 3/4			
R52	Mog	21761	500R52	130	12	Reflector High Bay-Light I.F. BB (4, 19, 23, 34, 73, 92)*	7600	500	2000	C-7A	11 3/4			
T20	Med BiPost	21872	500T20/50	130	12	I.F. HRG (15, 52, 73, 89, 99)*	9800	500	1000	C-13	6 1/2	4		

750 WATTS



PS52	Mog	22000	750	130	12	Clear, BB (4, 23, 92)**	17040	750	1000	CC-8	13	9 1/2		
R52	Mog	22080	750R52	120	12	Reflector High Bay-Light I.F. BB (14, 19, 23, 34, 73, 92)*	13000	750	2000	C-7A	11 3/4			
		22082	750R52	130	12	Reflector High Bay-Light I.F. BB (14, 19, 23, 34, 73, 92)*	13000	750	1500	C-7A	11 3/4			
		T24	Med BiPost	22117	750T24	130	24	Inside Frost, HRG (15, 52, 73, 89)*	14800	750	1000	C-13	9 3/16	5 1/2

1000 WATTS

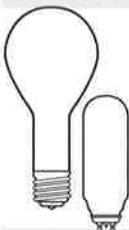

PS52	Mog	22301	1000/99	130	12	Clear-Extended Service, BB (23)*	19800	1000	2500	C-7A	13	9 1/2		
		22260	1000	130	12	Clear, BB (4, 23, 92)*	23740	1000	1000	CC-8	13	9 1/2		
		22280	1000	250	12	Clear, BB (4, 23, 92)*	17700	1000	2000	C-7A	13	9 1/2		
		22284	1000	277	12	Clear, BB (4, 23, 92)*	17700	1000	2000	C-7A	13	9 1/2		
T24	Med BiPost	22479	1M/T24	120	24	Inside Frost, HRG (15, 52, 73, 89)*	21200	1000	1000	C-13	9 3/16	5 1/2		

1500 WATTS

PS52	Mog	22592	1500	130	12	Clear, BB (4, 20, 23, 92)*	34400	1500	1000	C-7A	13	9 1/2		
------	-----	-------	------	-----	----	----------------------------	-------	------	------	------	----	-------	--	--

LUMEN RATED TRAFFIC SIGNAL LAMPS

EXTENDED GROUP REPLACEMENT SERVICE



P25	Med	20094	1950L/P25/TS	120	60	Clear-Traffic Signal (BDTH), BB (23)*	1950	165	8000	C-9	4 3/4	3		
		20096	1950L/P25/TS	125	60	Clear-Traffic Signal (BDTH), BB (23)*	1950	165	8000	C-9	4 3/4	3		
		20097	1950L/P25/TS	130	60	Clear-Traffic Signal (BDTH), BB (23)*	1950	165	8000	C-9	4 3/4	3		

INCANDESCENT LAMPS

BY AMPERES



S8	SC Pf	23478	55A/S8	12	100	Clear-Marine Signal. Spiral lead (37)*		500		C-8	2	1 1/8		
		23501	77A/S8	12	100	Clear-Marine Signal. Spiral lead (37)*		500		C-8	2	1 1/8		
T8	SC Pf	23258	4A/T8SCP	9	24	Clear-Sound Reproduction, Source WxH: 4.8 x 1.2mm. ANST: BXM, NPBB55 (1, 37, 55, 61)*	560	500		C-6	3 1/8	1 15/32		

To save energy costs, find the bulbs with the light output you need, then choose the one with the lowest watts. To convert inches to millimeters, multiply by 25.4.
 © Means this lamp meets Federal Minimum Efficiency Standards. (*) * All footnote references found at the end of this section. ➤ Reduced Wattage



Bulb	Base	Product Code	Lamp Description	Volts	Case Qty.	Additional Information	Lumens	Watts	Life Hours	Filament Design	MOL in.	LCL in.	Color Temp. K	Approx. Beam Spread
------	------	--------------	------------------	-------	-----------	------------------------	--------	-------	------------	-----------------	---------	---------	---------------	---------------------

INCANDESCENT LAMPS

BY AMPERES (Continued)



T8	SC Bay	23226	7.5A/T8/92SC	10	24	Clear-Sound Reproduction Optical Comparator. Source WxH: 1.8 x 4.6mm. ANSI: BXE, BB (1, 23, 61)*	1620	100	1000	C-8Z	3 1/8	1 3/4		
R40	Med	23423	21A/R40/FL	12	24	Reflector Flood-I.F. Swimming pool. BDTH, HORIZ, HRG, BB (15, 21, 23, 35, 53)*		1000		C-2V	6 11/16			

AIRPORT LAMPS

30 WATTS



T10	Med Pf	23294	6.6A/T10/1P	30W	60	Clear (1)*	400	30	1000	C-2V	3 15/16	1 1/2		
-----	--------	-------	-------------	-----	----	------------	-----	----	------	------	---------	-------	--	--

40 WATTS

T10	Med Pf	15921	40T10P	120	60	Clear (1)*	400	40	1000	CC-2V	3 15/16	1 1/2		
-----	--------	-------	--------	-----	----	------------	-----	----	------	-------	---------	-------	--	--

45 WATTS



PAR38	Med Skirt	15937	45PAR38/6.6	6.6A	12	Flood, BB (15, 23)*	700	45	800	C-6	5 5/16			
PAR56	Scrw Term	23310	6.6A/PAR56/5	45W	12	Stippled cover (15)*	700	45	1000	C-8	4 1/2			
T10	Med Pf	23295	6.6A/T10P	45W	60	Clear (1)*	675	45	1000	C-2V	3 15/16	1 1/2		

120 WATTS



PAR64	Scrw Term	39395	120PAR	6	12	Transmissometer. Filament Shielded. Very Narrow Spot (15)*	780	120	3000	C-6	4			
-------	-----------	-------	--------	---	----	--	-----	-----	------	-----	---	--	--	--

200 WATTS



T14	Med Pf	23298	6.6A/T14P	200W	24	Clear (1)*	4900	200		C-13	5 3/4	2 3/16		
-----	--------	-------	-----------	------	----	------------	------	-----	--	------	-------	--------	--	--

204 WATTS

T14	Med Pf	23300	6.6A/T14/2P	204W	24	Clear (1)*	4220	204	500	C-13	5 3/4	2 3/16		
-----	--------	-------	-------------	------	----	------------	------	-----	-----	------	-------	--------	--	--

210 WATTS

T14	Med Pf	34677	6.6A/T14/3P	210W	24	Clear, HRG (1, 15)*	4800	210	300	C-13	5 3/4	2 3/16		
-----	--------	-------	-------------	------	----	---------------------	------	-----	-----	------	-------	--------	--	--

503 WATTS



T20	Med BiPost	23417	20A/T20/3	503W	12	Clear, HRG (1, 15, 73, 89)*	10300	503	500	C-13	6 1/2	2 21/32		
-----	------------	-------	-----------	------	----	-----------------------------	-------	-----	-----	------	-------	---------	--	--

620 WATTS

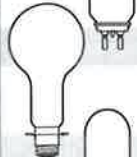

PS40	Mog Pf	21950	620PS40P	120	24	Clear	11200	620	3000	C-9	10 1/16	5 11/16		
		21952	620PS40P	130	24	Clear	11200	620	3000	C-9	10 1/16	5 11/16		

1000 WATTS



T20	Mog BiPost	22429	1M/T20BP	120	12	Clear-Beacon, HRG (1, 15)*	22000	1000	500	C-13	9 1/2	4		
-----	------------	-------	----------	-----	----	----------------------------	-------	------	-----	------	-------	---	--	--

1200 WATTS

T20	Mog BiPost	22524	1200T20	115	12	Clear-Beacon, HRG (1, 15, 73, 99)*	29600	1200	750	CC-8	9 1/2	4		
-----	------------	-------	---------	-----	----	------------------------------------	-------	------	-----	------	-------	---	--	--

MULTIPLE STREET LIGHTING LAMPS

GROUP REPLACEMENT SERVICE



PS25	Med	19939	189PS25/64	130	60	Clear, BB (23)*		189	3000	C-9	6 15/16	5 1/4		
PS35	Mog	20772	295PS35/58	125	24	Clear, BB (23)*		295	3000	C-9	9 3/8	7		
PS40	Mog	21408	405PS40/54	120	24	Clear, BB (23)*	6850	405	3000	C-9	9 3/4	7		

EXTENDED GROUP REPLACEMENT SERVICE

A23	Med	42392	105A23/12	125	120	Clear, BB (23)*		105	12000	C-9	5 15/16	4 7/16		
PS25	Med	42663	205PS25/12	125	60	Clear, BB (23)*		205	12000	C-9	6 15/16	5 1/4		
PS35	Mog	21307	327PS35	125	24	Clear, BB (23)*		327	6000	C-9	9 3/8	7		



Bulb	Base	Product Code	Lamp Description	Volts	Case Qty.	Additional Information	Life Watts	Hours	Filament Design	MOL in.	Color Temp. K	Approx. Beam Spread
------	------	--------------	------------------	-------	-----------	------------------------	------------	-------	-----------------	---------	---------------	---------------------

DECORATIVE LAMPS

15 WATTS

B8	Cand	27500	15BC/CD2	120	120	Clear-Blunt Tip (9)*	15	1500	C-7A			
CA8	Cand	47929	15CAC CD/2	120	60	Clear-Bent Tip (9)*	15	1500	C-7A	4 1/8		
		41524	15CAC/L	120	120	Clear-Bent Tip, LL	15	4000	C-7A	4 1/8		
		47930	15CAC/F CD/2	120	60	Frost-Bent Tip (9)*	15	1500	C-7A	4 1/8		
F10	Cand	47928	15FC CD/2	120	60	Clear-Flame (9)*	15	1500	C-7A	3 1/8		
		47927	15FC/AU CD/2	120	60	Auradescent-Flame (9)*	15	1500	C-7A	3 1/8		
G16 1/2	Cand	12578	15GC/L	120	60	Clear-Globe, LL	15	4000	C-7A	3		

25 WATTS

B10	Cand	15787	25BC 25PK	120	200	Clear-Blunt Tip, BDTH (76)*	25	1500	C-7A	3 3/4		
		47939	25BC CD/2	120	60	Clear-Blunt Tip, BDTH (9, 76)*	25	1500	CC-2V	3 3/4		
B13	Med	22756	25BM CD/2	120	60	Clear-Blunt Tip (9)*	25	1500	C-9	4 5/8		
CA10	Cand	15777	25CAC 25PK	120	200	Clear-Bent Tip, BDTH (76)*	25	1500	CC-2V	4 1/8		
		47933	25CAC CD/2	120	60	Clear-Bent Tip, BDTH (9, 76)*	25	1500	CC-2V	4 1/8		
		16045	25CAC CD/4	120	30	Clear-Bent Tip, BDTH (44, 76)*	25	1500	CC-2V	4 1/8		
		47934	25CAC/F CD/2	120	60	Frost-Bent Tip, BDTH (9, 76)*	25	1500	CC-2V	4 1/8		
		16046	25CAC/F CD/4	120	30	Frost-Bent Tip, BDTH (44, 76)*	25	1500	CC-2V	4 1/8		
		40045	25CAC/L	120	120	Clear-Bent Tip, BDTH, LL (76)*	25	4000	CC-2V	4 1/8		
		18890	25FM CD/2	120	30	Clear-Flame (9)*	25	1500	C-6	4 3/8		
F15	Med	18895	25FM/W CD/2	120	30	White-Flame (9)*	25	1500	C-6	4 3/8		
		18891	25FM/A CD/2	120	30	Amber-Flame (9)*	25	1500	C-6	4 3/8		
		18894	25FM/AU CD/2	120	30	Auradescent-Flame (9)*	25	1500	C-6	4 3/8		
		11303	25GC 12PK	120	120	Clear-Globe	25	1500	C-9	3		
G16 1/2	Cand	15790	25GC 25PK	120	100	Clear-Globe	25	1500	C-9	3		
		17722	25GC CD/2	120	60	Clear-Globe (9)*	25	1500	C-9	3		
		23510	25GC/AU CD/2	120	60	Auradescent - Globe (9)*	25	1500	C-9	3		
		39679	25GC/W 12PK	120	120	White-Globe	25	1500	C-9	3		
		17729	25GC/W CD/2	120	60	White-Globe (9)*	25	1500	C-9	3		
		43158	25GC/L	120	60	Clear-Globe, LL	25	4000	C-9	3		
		G25	Med	12983	25G25 6PK	120	6	Clear-Globe	25	1500	C-9	4 1/2
25545	25G25 CPK			120	24	Clear-Globe	25	1500	C-9	4 1/2		
20408	25G25/L 24PK			120	24	Clear-Globe, LL	25	4000	C-9	4 1/2		
12982	25G25/W 6PK			120	6	White-Globe	25	1500	C-9	4 1/2		
25546	25G25/W CPK			120	24	White-Globe	25	1500	C-9	4 1/2		
20410	25G25/W/L 24PK			120	24	White-Globe, LL	25	4000	C-9	4 1/2		

40 WATTS

B10	Cand	15788	40BC 25PK	120	200	Clear-Blunt Tip, BDTH (76)*	40	1500	CC-2V	3 3/4		
		19110	40BC 6PK CD/2	120	30	Clear-Blunt Tip, BDTH (9, 76)*	40	1500	CC-2V	3 3/4		
		19981	40BC CD/4	120	30	Clear-Blunt Tip, BDTH (44, 76)*	40	1500	CC-2V	3 3/4		
		27292	40BFC/CD2 6PK	120	30	Faceted-Blunt Tip, BDTH (9, 76)*	40	1500	CC-2V	3 3/4		
B13	Med	12993	40BM CD/2	120	60	Clear-Blunt Tip (9)*	40	1500	C-9	4 5/8		
		27310	40BM/CD4	120	24	Clear-Blunt Tip (44)*	40	1500	C-9	4 5/8		
CA9	Med	47945	40CAM CD/2	120	60	Clear-Bent Tip, BDTH (9, 76)*	40	1500	CC-2V	4 9/16		
		16049	40CAM CD/4	120	30	Clear-Bent Tip, BDTH (44, 76)*	40	1500	CC-2V	4 9/16		
		12994	40CAM/F CD/2	120	60	Frost-Bent Tip, BDTH (9, 76)*	40	1500	CC-2V	4 9/16		
		22813	40CAM/LL/BB CD/2	120	30	Clear-Bent Tip, House Garden™ LL, BDTH (9, 23, 76)*	40	4000	CC-2V	4 9/16		



Bulb	Base	Product Code	Lamp Description	Volts	Case Qty.	Additional Information	Life Watts	Filament Hours	Design	MOL in.	Color Temp. K	Approx. Beam Spread
DECORATIVE LAMPS												
40 WATTS (Continued)												
	CA10	Cand	15778	40CAC 25PK	120	200	Clear-Bent Tip, BDTH (76)*	40	1500	CC-2V	4 1/8	
			19107	40CAC CD/2	120	30	Clear-Bent Tip, BDTH (9, 76)*	40	1500	CC-2V	4 1/8	
			16047	40CAC CD/4	120	30	Clear-Bent Tip, BDTH (44, 76)*	40	1500	CC-2V	4 1/8	
			47941	40CAC/F CD/2	120	60	Frost-Bent Tip, BDTH (9, 76)*	40	1500	CC-2V	4 1/8	
			16048	40CAC/F CD/4	120	30	Frost-Bent Tip, BDTH (44, 76)*	40	1500	CC-2V	4 1/8	
			40050	40CAC/L	120	120	Clear-Bent Tip, BDTH, LL (76)*	40	4000	CC-2V	4 1/8	
			22812	40CAC/LL/BB CD/2	120	30	Clear-Bent Tip, House Garden™ LL, BDTH (9, 23, 76)*	40	4000	CC-2V	4 1/8	
	F15	Med	18896	40FM CD/2	120	30	Clear-Flame (9)*	40	1500	C-6	4 3/8	
			18899	40FM/W CD/2	120	30	White-Flame (9)*	40	1500	C-6	4 3/8	
			18897	40FM/AU CD/2	120	30	Auradescent-Flame (9)*	40	1500	C-6	4 3/8	
	G16 1/2	Cand	14958	40GC 12PK	120	120	Clear-Globe, BDTH (4, 76)*	40	1500	C-9	3	
			17730	40GC CD/2	120	60	Clear-Globe, BDTH (4, 9, 76)*	40	1500	C-9	3	
			23511	40GC/AU CD/2	120	60	Auradescent - Globe, BDTH (4, 76)*	40	1500	C-7A	3	
			12999	40GC/W 12PK	120	120	White-Globe, BDTH (4, 76)*	40	1500	C-9	3	
			17732	40GC/W CD/2	120	60	White-Globe, BDTH (4, 9, 76)*	40	1500	C-9	3	
	G25	Med	12980	40G25 6PK	120	6	Clear-Globe	40	1500	C-9	4 1/2	
			25548	40G25 CPK	120	24	Clear-Globe	40	1500	C-9	4 1/2	
			20419	40G25/L 24PK	120	24	Clear-Globe, LL	40	4000	C-9	4 1/2	
			12979	40G25/W 6PK	120	6	White-Globe	40	1500	C-9	4 1/2	
			25547	40G25/W CPK	120	24	White-Globe	40	1500	C-9	4 1/2	
			22991	40G25/W/PRO 6PK	120	6	White-Globe	40	1500	C-9	4 1/2	
			20420	40G25/W/L 24PK	120	24	White-Globe, LL	40	4000	C-9	4 1/2	
			20823	40G25/NEO 6PK	120	6	Neodymium - Enrich™	40	1500	C-9	4 1/2	
G30	Med	27499	40G30/W	120	24	White-Globe	40	2500	CC-6	5		
G40	Med	37914	40G40	120	24	Clear-Globe	40	2500	CC-6	6 15/16		
		36191	40G40/W 6PK	120	6	White-Globe	40	2500	CC-6	6 15/16		
60 WATTS												
	B10	Cand	47949	60BC CD/2	120	60	Clear-Blunt Tip, BDTH (9, 13, 76)*	60	1500	CC-2V	3 3/4	
			27298	60BC/CD4	120	120	Clear-Blunt Tip, BDTH (13, 44, 76)*	60	1500	CC-2V	3 3/4	
	B13	Med	22757	60BM CD/2	120	60	Clear-Blunt Tip (9)*	60	1500	C-9	4 5/8	
			27497	60BM/CD4	120	24	Clear-Blunt Tip (44)*	60	1500	C-9	4 5/8	
	CA9	Med	47948	60CAM CD/2	120	60	Clear-Bent Tip, BDTH (9, 13, 76)*	60	1500	CC-2V	4 9/16	
			21009	60CAM CD/4	120	30	Clear-Bent Tip, BDTH (13, 44, 76)*	60	1500	CC-2V	4 9/16	
	CA10	Cand	15781	60CAC 25PK	120	200	Clear-Bent Tip, BDTH (13, 76)*	60	1500	CC-2V	4 1/8	
			19153	60CAC 6PK CD/2	120	30	Clear-Bent Tip, BDTH (13, 76)*	60	1500	CC-2V	4 1/8	
			16050	60CAC CD/4	120	30	Clear-Bent Tip, BDTH (13, 44, 76)*	60	1500	CC-2V	4 1/8	
			47947	60CAC/F CD/2	120	60	Frost-Bent Tip, BDTH (9, 13, 76)*	60	1500	CC-2V	4 1/8	
			16051	60CAC/F CD/4	120	30	Frost-Bent Tip, BDTH (13, 44, 76)*	60	1500	CC-2V	4 1/8	
	G16 1/2	Cand	23091	60GC CD/2	120	60	Clear-Globe, BDTH (4, 9, 76)*	60	1500	C-9	3	
			23093	60GC/W CD/2	120	60	White-Globe, BDTH (4, 9, 76)*	60	1500	C-9	3	
	G25	Med	14846	60G25 6PK	120	6	Clear-Globe	60	1500	C-9	4 1/2	
			20427	60G25 24PK	120	24	Clear-Globe	60	1500	C-9	4 1/2	



Bulb	Base	Product Code	Lamp Description	Volts	Case Qty.	Additional Information	Life Watts	Flament Hours	MOL Design	MOL in.	Color Temp. K	Approx. Beam Spread	
DECORATIVE LAMPS													
60 WATTS (Continued)													
	G25	Med	14848	60G25/W 6PK	120	6	White-Globe	60	1500	C-9	4 1/2		
			20428	60G25/W 24PK	120	24	White-Globe	60	1500	C-9	4 1/2		
	G30	Med	14850	60G30/W 6PK	120	24	White-Globe. Retail Pack	60	2500	CC-9	5		
		G40	Med	14187	60G40 6PK	120	6	Clear-Globe	60	2500	CC-6	6 15/16	
				49780	60G40/W 6PK	120	6	White-Globe	60	2500	CC-6	6 15/16	
		16741	60G40/W CPK	120	24	White-Globe	60	2500	CC-6	6 15/16			
		36193	75G40/W 6PK	120	6	White-Globe	75	2500	CC-6	6 15/16			
E17	Med	10695	75E17/TF 6PK	120	120	Post Light, Teflon® Coated, House Garden™ BB (23, 47)*	75	4000	CC-6	5			
100 WATTS													
	F20	Med	27287	100F20/TF/POST	120	120	Post Light, Teflon® Coated, House Garden™ BB (23, 47)*	100	3000	CC-9	5		
150 WATTS													
	G40	Med	49781	100G40/W 6PK	120	6	White-Globe	100	2500	CC-6	6 15/16		
			16742	100G40/W CPK	120	24	White-Globe	100	2500	CC-6	6 15/16		
			16585	150G40/W	120	24	White-Globe	150	2500	CC-6	6 15/16		
PORTABLE LIGHTING PRODUCTS													
75 WATTS													
	R30	Med	44848	PLK-1	120	4	Plant Light Kit includes one 75R30/PL Plant Light lamp, UL listed holder and information booklet	75		CC-6			

Bulb	Base	Order Code	Lamp Description	Case Volts	Qty.	Additional Information	Lumens	Rated Avg. Life Hours	Watts	Fila-ment Design	MOL In	MOL (mm)	Temp K	Approx. Beam Spread	
EXPORT-ONLY LAMPS (See restrictions on page 1-32 under "General Information")															
	PAR38	Med Skirt	14506	75PAR/FL/65WM/EX	130	12	Watt-Miser®, Flood (15,23,56,96)*	675	65	2000	CC-6	5 9/16	(134.9)	2675	1750 30
			14505	75PAR/SP/65/WM/EX	130	12	Watt-Miser®, Spot (15,23,56,96)*	675	65	2000	CC-6	5 9/16	(134.9)	2675	5900 14
			14510	75PAR/FL/EX	120	12	Flood (15,23,56,96)*	765	75	2000	CC-6	5 9/16	(134.9)	2700	1750 33
			14523	75PAR/FL/EX	130	12	Flood (15,23,56,96)*	765	75	2000	CC-6	5 9/16	(134.9)	2700	1750 33
			14509	100PAR/FL/85WM/EX	120	6	Miser® Flood (14,15,23,56,96)*	930	85	2000	CC-6	5 9/16	(134.9)	2700	2000 37
	R40	Med	14549	100R/FL/EX	120	24	Reflector Flood, IF (4,35,56)*	1190	100	2000	CC-6	6 9/16	(166.7)	-	- -
			14559	100R/FL/EX	130	24	Reflector Flood (4,35,56)*	1190	100	2000	CC-6	6 9/16	(166.7)	-	- -
	PAR38	Med Skirt	14501	150PAR/FL/120WM/EX	120	12	Watt-Miser®, Flood (14,15,23,56,96)*	1370	120	2000	CC-6	5 9/16	(134.9)	2725	3600 30
			14502	150PAR/SP/120WM/EX	120	12	Watt-Miser®, Spot (14,15,23,56,96)*	1370	120	2000	CC-6	5 9/16	(134.9)	2725	9200 18
			14503	150PAR/FL/120WM/EX	130	12	Watt-Miser®, Flood (14,15,23,56,96)*	1370	120	2000	CC-6	5 9/16	(134.9)	2725	3600 30
			14531	150PAR/FL/EX	120	12	Flood (14,15,23,56,96)*	1740	150	2000	CC-6	5 9/16	(134.9)	2775	3100 36
			14532	150PAR/FL/EX	130	12	Flood (14,15,23,56,96)*	1740	150	2000	CC-6	5 9/16	(134.9)	2775	3100 36
	R40	Med	14535	150PAR/SP/EX	120	12	Spot (14,15,23,56,96)*	1740	150	2000	CC-6	5 9/16	(134.9)	2775	12000 16
			14561	150R/FL/EX	120	24	Reflector Flood, ANSI:DWCC, (4,35,46,56)*	1900	150	2000	CC-6	6 9/16	(166.7)	-	- -
			14563	150R/FL/EX	130	24	Reflector Flood (4,35,46,56)*	1900	150	2000	CC-6	6 9/16	(166.7)	-	- -

To save energy costs, find the bulbs with the light output you need, then choose the one with the lowest watts. To convert inches to millimeters, multiply by 25.4.
 © Means this lamp meets Federal Minimum Efficiency Standards. (*) * All footnote references found at the end of this section. ⚡ Reduced Wattage



GENERAL INFORMATION

PROTECTION FROM MOISTURE

When HRG or footnote 15 (Hard Glass) appears in the Lamp Designation or Description column, the outer bulbs are made of special thermal-shock-resistant glass. However, sometimes external protection of the lamps is also needed to eliminate the chance of bulb breakage due to contact with water during operation. Footnotes will indicate when external protection is needed. Where HRG is not shown, the bulb glass is such that the lamps require protection from exposure to mist or condensation as well as direct contact with water during operation. Cov-R-Guard™ lamps and some Saf-T-Gard® lamps (lamps coated with Teflon®) need no such protection from water. (Teflon® is a registered trademark of DuPont.)

RATED AVERAGE LIFE

Values are based on a large number of representative lamps under controlled laboratory conditions. Individual lamps or groups of lamps may vary from the Nominal Life. Lamp Life is a median value of life expectancy – the total operating time at which under normal conditions, 50% of any large group of initially installed lamps are expected to be still burning.

BASES

When Footnote 23 or BB (Brass Base) appears in the Lamp Designation or Description column, the lamp is supplied only with a brass base. If Brass Base (Footnote 23 or BB) does not appear, the lamp is supplied only with an aluminum base. Brass Bases are recommended for outdoor lighting applications.

BURNING POSITION

Unless otherwise stated, the lamp can be burned in any position. Limitations on lamp operating position are shown in the Description column. The following abbreviations are used:

BDTH (Burn lamp in Base Down To Horizontal Position)
 BUTV (Burn lamp in Base Up To Vertical Position)

EXPORT-ONLY LAMPS

The U.S. Energy Policy Act of 1992 and Canadian energy legislation prohibit the manufacture and/or importation of certain lamp types for sale in Canada, the United States, and its territories. The incandescent lamps in the section, "Export-Only Lamps," are for sale outside of these areas.

FOOTNOTES

- # Footnote
- 1 Burning position-base down only
 - 1A Because bulb coating may become electrically conductive, take precaution to avoid electric shock: use in sockets supplied by same voltage as marked on lamp. Do not install in higher-voltage series circuits.
 - 2 Burning position-horizontal
 - 2A Do not allow the bulb to be dragged across or to strike a hard surface since this action may cause minute cracks. Do not place lamp directly over the exposed person unless a protective screen or mesh is between lamp and user.
 - 3 Burning position - base up.
 - 3A Operate lamp only when bulb is cooled by direct immersion in water, to avoid overheating. Observe cleaning instructions.
 - 4 Avoid contact of hot glass bulb with liquid or metal, as glass may shatter.
 - 6 Design life in excess of 5000 hours. Actual life depends on service conditions.
 - 7 Base pins approximately parallel to plane of lead wires.
 - 8 For use only in equipment specially designed to maintain bulb and base temperatures within safe limits.
 - 9 Indicates total count of 2-lamp packs in shipping units. Multiply by 2 to determine actual quantity of lamps.
 - 10 Single contact medium bayonet base without pins, with a lug focusing sleeve as indicated. LCL and A.A. tolerance: $1/64$ in.
 - 11 To protect persons against risk of breakage, use a protective screen external to the lamp.
 - 12 Not recommended for horizontal burning.
 - 13 Unsatisfactory lamp operation is likely to occur in burning position between horizontal and base up, particularly between 45° from base up and base up.
 - 14 In "base up" use, heat eventually may deteriorate paper-lined or plastic sockets.
 - 15 Lamp is made of heat resistant glass (HRG).
 - 18 Operating position horizontal with locating lug up or down and with lamp supported by bulb rim.
 - 19 Burn within 25° of vertically base up.

Footnote

- 20 Recommended burning position: any within 60° of vertically base up or down; but lumen maintenance is best when burned vertically base up.
- 21 May not give satisfactory performance if any accessory equipment is attached to or touches the glass bulb. The bulb, although made of heat-resistant glass, may break if moisture falls on it.
- 23 Lamp base is a brass base (BB).
- 25 To produce all three levels of light, this lamp should be tightened firmly but not forcibly in the socket to assure that all contacts are connected.
- 28 For use only in porcelain sockets and fixtures so designed that the temperatures of the lamp and fixture do not exceed limits for satisfactory operation.
- 29 Average laboratory life is 200 hours for vacuum cleaners and 600 hours for sewing machine services.
- 31 Bulb top selected for minimum glass imperfections.
- 32 This 277-volt lamp should be enclosed if it is used on high-capacity low impedance electrical distribution systems. At the end of lamp life on such systems, the lamp may shatter, with risk of injury to persons or property if it is not suitably enclosed.
- 33 Light output is maintained best when burned within 45° of vertically base up.
- 34 May not give satisfactory performance if any accessory equipment is attached to or touches the glass bulb.
- 35 Should not be used in equipment where the base temperature will exceed 500°F (260°C)
- 36 Should be shielded against moisture falling on the bulb.
- 37 The plane containing the base axis and the major locking eyelet (the eyelet that is equidistant from the other two eyelets) is at right angles to the plane of the filament or lead wires. Distance from bottom base contact to bottom of the collar is .4
- 38 Special base. Lead wire to shell soldered at bottom.
- 39 Tungsten powder cleaner in bulb. Useful lamp life and maintenance of output depend on periodic removal from socket and rotating to scour bulb wall with tungsten powder to remove dark film that normally accumulates.
- 40 Operate base down within 45° of vertical. Any tilt should be in direction in which the filament plane faces.
- 41 Nominal watts. Actual watts are determined by multiplying the volts by the design amperes.
- 43 Design volts of range: 240
- 44 Indicates total count of 4-lamp packs in shipping units. Multiply by 4 to determine actual quantity of lamps.
- 46 This lamp produces base temperatures which may deteriorate paper-lined or plastic sockets. Use only in fixtures approved for this type and wattage bulb.
- 47 Teflon® coated. Teflon is a registered trademark of DuPont.
- 52 Operate base up, within 30° of vertical.
- 53 Use lamp only on circuits supplying the same voltage as marked on the bulb. DO NOT insert in household sockets.
- 55 Lamp base is a nickel plated brass base (NPBB).
- 56 Avoid use at short distances on materials that are inflammable or susceptible to heat damage.
- 58 For use only with heat-resistant connector and with lamp supported by bulb rim or metal shell of base.
- 59 For use only with heat-resistant connector and with lamp supported by bulb rim.
- 61 Maximum Excursion Radius: $3/8$ in.
- 62 Wattage shown is nominal. Design current is 0.139 amps at 120 volts.
- 64 Designed for base down burning but can be operated in other positions. Brightness maintenance is best when filament is viewed horizontally or from below when lamp is burned in any position other than base down.
- 66 Rated average life is based on 14-volt operation.
- 69 Light center length and A.A. tolerance: $1/16$ in.
- 70 Light center length and A.A. tolerance: $1/16$ in.
- 71 Burning position - plane through lamp axis and base terminals is horizontal.
- 72 Burning position - plane through lamp axis and base prongs is horizontal. Base is without insulator.
- 73 Collector grid.
- 74 High Intensity (Supplementary Lighting) lamps should be replaced only with an equivalent lamp having correct volts and watts for the fixture used. Substituting higher wattage lamps may cause damage to fixture.
- 76 Burn base down to horizontal.
- 78 Use only in fixtures rated for Cool Beam lamp operation.
- 80 Do not use lamp in application where it may be exposed to direct water splash. If lamp is used outdoors, it must be protected by an enclosed fixture or an overhang. Failure to properly protect the lamp can result in premature failure of the lamp.
- 83 Will operate in any burning position, but fixed-socket usage other than base up or continuous burning in any position in ambient temperatures above 150°F (66°C), may result in some loss of protective coating. Reflectors and accessories may raise bulb temperature and cause some loss of protective coating.
- 88 If lamp is cracked or broken, replace immediately. The lamp may continue to light, but the inner bulb is pressurized and could unexpectedly shatter. Dispose of with care.
- 89 Insertion in "twist-in" type sockets requires only a slight clockwise turn - excessive force may break the bulb.
- 92 LAMP SHOULD BE SCREWED FIRMLY INTO THE SOCKET, ALTHOUGH NOT FORCIBLY so that it will not loosen and fall out. USE LAMP-GRIP SOCKETS OR WIRE GUARDS where vibration is present, particularly if lamp is used above or close to people. DO NOT ATTEMPT TO USE THE LAMP IF THE FILAMENT HAS BEEN BROKEN even though ends of filament are in contact. Also, HAVE CIRCUITS PROPERLY FUSED. DO NOT USE IF GLASS IS CRACKED.
- 93 Use only in swimming pool fixtures that comply with applicable safety standards and codes.
- 94 Observe operating and exposure limitations stated on packaging material, fixture and/or instruction booklet enclosed.
- 95 Do not use in hazardous locations such as near gasoline or other combustible materials or vapor.
- 96 Under moist conditions, metal parts of lamp and lamp holder may become a shock hazard. Therefore, disconnect from circuit before touching.
- 97 While this lamp was carefully inspected before shipment, the glass bulb may crack when subjected to abnormal pressure. Therefore, it is recommended that the bulb be grasped with a cloth or glove when removing or installing the lamp in a tight-fitting socket.
- 98 For use only in equipment designed for lamps of this type and wattage, having ventilation adequate to maintain bulb and base temperatures within safe limits.
- 99 Indicates total count of 3-lamp packs in shipping units. Multiply by 3 to determine actual quantity of lamps.
- 100 Caution: do not use in applications where contact with rain, snow, oil, lubricants, water or other liquids is possible as breakage and shattering glass may occur OR where gasoline or other combustible materials or vapors are present.
- 101 Caution: for safe use, use only where night light and bulb cannot contact bed coverings, hanging drapes or other materials that may present a fire hazard.
- 102 Bulb should be used in household voltage high intensity lamps only. Check fixtures for correct bulb number.
- 103 Warning - temperatures sufficient to cause burns may occur. Do not touch bulb during operation. Allow at least 5 minutes for bulb to cool before touching. Keep bulb out of reach of children and pets. To avoid risk of fire, do not use this bulb in enclosed fixtures or with lamp shades. Keep paper or other flammable or heat sensitive materials at least 12 inches away from the bulb. Do not use in paper lined sockets.
- 104 Caution - Burn base down only.
- 105 Caution - This lamp produces base temperatures which may deteriorate paper-lined or plastic sockets. Use only in fixtures approved for this wattage bulb.



PAR38

HIR/XL™ (ULTRA LONG LIFE) PAR38 LAMPS

45 WATTS	2-5
55 WATTS	2-6
90 WATTS	2-8

HIR™ PAR38 LAMPS

50 WATTS	2-6
60 WATTS	2-7
80 WATTS	2-8
100 WATTS	2-8

HALOGEN LONG LIFE PAR38 LAMPS

45 WATTS	2-5
60 WATTS	2-7
75 WATTS	2-8
90 WATTS	2-8

STANDARD HALOGEN PAR38 LAMPS

50 WATTS	2-5
100 WATTS	2-8

HALOGEN COOL BEAM PAR38 LAMPS

90 WATTS	2-8
----------------	-----

QUARTZLINE® PAR38 LAMPS

250 WATTS	2-9
-----------------	-----

COMPACT PAR

COMPACT HIR™ PAR30 LAMPS

50 WATTS	2-6
----------------	-----

HALOGEN COMPACT PAR30 LAMPS

50 WATTS	2-5
60 WATTS	2-7
75 WATTS	2-7

HALOGEN COMPACT PAR20 LAMPS

50 WATTS	2-5
----------------	-----

HALOGEN COMPACT PAR30 LONG NECK LAMPS

50 WATTS	2-6
75 WATTS	2-7

HALOGEN A-LINE LAMPS

50 WATTS	2-6
90 WATTS	2-8

HALOGEN PAR36 LAMPS

35 WATTS	2-5
50 WATTS	2-6

MR

TURN AND LOCK (TAL) CONSTANTCOLOR® LAMPS

50 WATTS	2-9
----------------	-----

CONSTANTCOLOR® PRECISE™ COVER GLASS MR16 LAMPS

20-71 WATTS	2-10
-------------------	------

CONSTANTCOLOR® PRECISE™ MR16 LAMPS

20-71 WATTS	2-9
-------------------	-----

STANDARD MR16 LAMPS

20-50 WATTS	2-9
-------------------	-----

STANDARD MR11 LAMPS

20-35 WATTS	2-9
-------------------	-----

QUARTZ HALOGEN LAMPS

5-100 WATTS	2-10
-------------------	------

QUARTZLINE® HALOGEN

QUARTZLINE® HIR™ LAMPS

225 WATTS	2-11
350 WATTS	2-12
900 WATTS	2-12

QUARTZLINE® HALOGEN LAMPS

45-75 WATTS	2-11
100 WATTS	2-11
150 WATTS	2-11
200 WATTS	2-11
235 WATTS	2-12
250 WATTS	2-12
300 WATTS	2-12
400-425 WATTS	2-12
500 WATTS	2-12
1000 WATTS	2-13
1500 WATTS	2-13
6000-6600 WATTS	2-13

AIRPORT LAMPS LISTED BY AMPHERES

200-500 WATTS	2-13
---------------------	------

TUBULAR QUARTZ HEAT LAMPS

300-375 WATTS	2-14
500 WATTS	2-14
1000 WATTS	2-14
1200-1600 WATTS	2-14
2000 WATTS	2-14
2500 WATTS	2-14
3650-5000 WATTS	2-14



BULB IDENTIFICATION

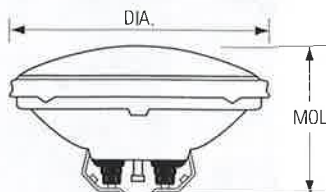

DIA. in.: Diameter of bulb at widest point.

MOL in.: Maximum Overall Length including base or pins.

LCL in.: Distance between the center of the filament and the Light Center Length reference plane.

Note: Lamp drawings are not drawn to scale. Be sure to check size and dimension information when identifying each lamp.

To convert inches to millimeters, multiply the dimension (in inches) by 25.4 (i.e. 1.5" x 25.4 = 38.1 mm).

FILAMENT IDENTIFICATION



C-8
CC-8



C-2V
CC-2V



C-6
CC-6



CC-8

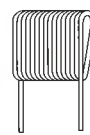

C-6
Oval

BASE IDENTIFICATION



2-Pin
(Round)
GX5.3



Can DC
Bay



2-Pin
GY6.35



Recessed
Single
Contact
R7s



Screw
Terminals

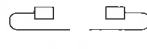

4" Leads

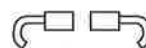

1" Ribbon
Leads



6" Flex
Leads



2-Pin
GU-4



2-Pin
GU-5.3



2-Pin
G4



Turn & Lock
GU-7



2-Pin PF



Min
Screw
E-10



DC Bay
BA15d



Min Cand
E11



Med
Screw
E26

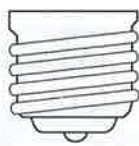

Mog
Screw
E39

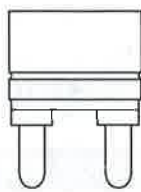

Mogul
BiPost
G38

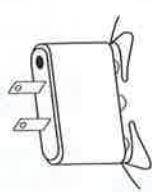

Ext. Mog
End Pr
GX16d

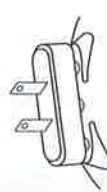

Mog End
PR
GX16d

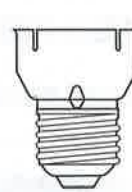

Med
Skirted
E26/50x39



INTRODUCTION

Halogen lamps provide a small, highly efficient white light source with excellent color rendering. Unlike standard incandescent lamps, halogen lamps use a halogen gas which allows the bulbs to burn more intensely without sacrificing life.

Compared to incandescent lamps, halogen lamps provide:

- Crisp, white light
- Excellent beam control
- High Lumen Maintenance
- Energy savings
- Compact size
- Long Life

PRODUCT INFORMATION

PAR38

HIR/XL™ Ultra Long Life PAR (PAR38) (pg 2-5, 2-6, and 2-8)

- Ultra long life – 6000 hours
- Up to 17% more energy efficient
- Available in: 45, 55, and 90 watt /SP12° and FL40°

HIR™ PAR (PAR38) (pg 2-6, 2-7, and 2-8)

- Most efficient halogen lamps – 35% more lumens per watt
- GE's exclusive IR film recycles wasted energy
- 50% longer life – 3000 hours

Halogen Long Life PAR (PAR38) (pg 2-5, 2-7, and 2-8)

- 25% longer life – 2500 hours
- Wide variety of wattages and beam spreads

Standard Halogen PAR (PAR38) (pg 2-5 and 2-8)

- Crisp, white light
- Life – 2000 hours

Quartzline® PAR (PAR38) (pg 2-9)

- High light output for long throws (250 watt)
- Long life – 4200 hours

COMPACT PAR

Compact HIR™ (PAR30) (pg 2-6)

- Most efficient PAR30 - 35% more lumens per watt
- Long life – 3000 hours

Compact PAR Halogen (PAR20/PAR30) (pgs 2-5, 2-6, and 2-7)

- Small size for "low profile" fixture
- Energy efficient replacement for R20/R30 lamps
- Long life – 2500 to 3000 hours

Long Neck PAR30 Halogen (PAR30L) (pgs 2-6 and 2-7)

- Energy efficient replacement for R30 lamps
- Ideal for recessed fixtures

MR

Turn and Lock (TAL) ConstantColor® (MR16) (pg 2-9)

- User-friendly base... easy to install and remove
- Over 90% maintained light over life
- No color shift
- Suitable for use in open fixtures

ConstantColor® Precise™ Cover Glass (pgs 2-10)

- Cover glass lens protects bulb from dust and dirt
- Suitable for use in open fixtures

ConstantColor® Precise™ (MR16) (pgs 2-9, and 2-10)

- Precise beam control
- No color shift
- Over 90% maintained light output over life
- Long life – up to 6000 hours (50-watt)

Standard MR (MR16/MR11) (pgs 2-9)

- Small size for "low profile" look
- Crisp, white light

LINEAR QUARTZ

Linear Quartzline® HIR™ (pgs 2-11, 2-12, and 2-13)

- 30%-40% energy cost savings vs. standard quartz lamps
- 95% maintained light output over life
- Cooler operation increases fixture life

* All products are compared to their standard counterpart



HEADINGS IN THIS CATALOG SECTION

The following terms and descriptions can help you when checking Halogen lamp specifications and when ordering products. Within each product line, lamps are divided into families. Within families, lamps are listed by wattage. In each of these groups, lamps are listed alphabetically by bulb shape.

Energy Used - Nominal Watts:

Energy Used (as defined by FTC Lamp Label Rules). To estimate energy consumption (kWh), multiply watts x hours of use and divide by 1000.

Case Quantity:

Number of product units packed in a case.

Bulb:

Bulb shape followed by its size (the maximum diameter of the bulb expressed in eighths of an inch).

Product Code:

It is important to use this five-digit code when ordering to ensure that you receive the exact product you require.

Volts:

Lamp data is based on operation at rated voltage.

Base:

The type of base.

Lamp Description:

The lamp's identification code.

Additional Information

Typical application and/or other important information including footnotes ()*.

Approximate CBCP (Center Beam Candlepower):

For reflector type lamps, Center Beam Candlepower is the intensity (candelas) at the center or maximum intensity of the beam.

Reference Color Temperature Kelvins (K):

"Warmth" or "Coolness" of the lamp, measured in Kelvins (K). The higher the temperature, the cooler the appearance of the light.

LCL in.:

Distance between the center of the filament and the Light Center Length reference plane, in inches.

MOL in.:

Maximum Overall Length in inches.

Filament Design:

Filaments are designated by a letter combination in which C is a coiled wire filament, CC is a coiled wire that is itself wound into a larger coil, and SR is a straight ribbon filament. Numbers represent the type of filament-support arrangement.

Life - Hours:

Life (as defined by FTC Lamp Label Rules) is rated average life in hours.

Light Output - Lumens:

Light output (as defined by FTC Lamp Label Rules) is rated average lumens.

Watts	Bulb	Base	Product Code	Lamp Description	Case Qty.	Volts	Additional Information	Rated Avg. Life Hours	Filament Design	MOL in.	LCL in.	Color Temp. K	CBCP
-------	------	------	--------------	------------------	-----------	-------	------------------------	-----------------------	-----------------	---------	---------	---------------	------

HALOGEN PAR36 LAMPS

35 WATTS

	35	PAR36	Scrw Term	19873	↔	35PAR36/H/SP5°	12	12	Spotlight (15)*	250	4000	C-6	2 ³ / ₄	3050	25000
				19876	↔	35PAR36/H/SP8°	12	12	Spotlight (15)*	250	4000	C-6	2 ³ / ₄	3050	20000

35 PAR36 / H / SP 8°

Identifies the lamp's wattage.

Identifies the lamp shape and the bulb diameter in eighths of inches.

Identifies the lamp type.

Identifies beam angle, code may also include packaging information.

Identifies as Spotlight.

WHEN YOU DON'T KNOW THE LAMP DESCRIPTION

1. Identify bulb shape next to lamp information.
2. Measure bulb diameter using ruler in Appendix section page A-1 to determine width in eighths of an inch.
3. Identify base type using table on page 2-2.
4. Find your lamp in the table containing the bulb shape, size and base, which are all listed by wattage.

HALOGEN BRAND NAME CROSS-REFERENCE

GE	OSRAM/SYLVANIA	PHILIPS
HIR/XL™ PAR	—	—
HIR™ PAR	—	—
Halogen Long Life PAR	Capsylite® PAR	Masterline™ 2500
Standard Halogen PAR	—	Masterline™ 2000
Compact PAR	Capsylite® PAR	Masterline™ PAR
Turn and Lock (TAL) ConstantColor®	—	—
ConstantColor® Precise™	Tru-Aim Titan®	Continuum Color®
Standard MR16	Tru-Aim®	Continuum®
Halogen A-Line	Capsylite® A-Line (Midbreak)	Halogena®

ATTENTION: This brand-name cross reference chart is provided only as a quick reference. Other lamp company brand listings may only represent a near equivalent, versus an identical match to GE Lighting brands. Individual lamp manufacturers' performance specifications should be consulted. Lamp performance may be affected by environmental conditions, and/or other auxiliary equipment.



Watts	Bulb	Base	Product Code	Lamp Description	Case Volts	Qty.	Additional Information	Lumens	Rated Avg. Life Hours	Filament Design	MOL in.	LCL in.	Color Temp. K	CBCP
-------	------	------	--------------	------------------	------------	------	------------------------	--------	-----------------------	-----------------	---------	---------	---------------	------

HALOGEN PAR36 LAMPS

35 WATTS

	35	PAR36	Scrw Term	19873	35PAR36/H/SP5°	12	12	Spotlight (15)*	250	4000	C-6	2 ³ / ₄	3050	25000
				19876	35PAR36/H/SP8°	12	12	Spotlight (15)*	250	4000	C-6	2 ³ / ₄	3050	20000
				19877	35PAR36/H/FL30°	12	12	Floodlight (15)*	250	4000	C-6	2 ³ / ₄	3050	900

HALOGEN LONG LIFE PAR38 LAMPS

45 WATTS

	45	PAR38	Med Skirt	17470	45PAR/H/SP10°	120	6	Spotlight (15, 23, 56, 88, 96)*	510	2500	CC-8	5 ⁵ / ₁₆	2750	7000
	45			16229	45PAR/H/SP10°	130	12	Spotlight (15, 23, 56, 88, 96)* Ratings @120 Volts	510 390	2500 5000	CC-8	5 ⁵ / ₁₆	2750	7000
	45			17471	45PAR/H/FL25°	120	6	Floodlight (15, 23, 56, 88, 96)*	510	2500	CC-8	5 ⁵ / ₁₆	2750	1800
	45			16231	45PAR/H/FL25°	130	12	Floodlight (15, 23, 56, 88, 96)* Ratings @ 120 Volts	510 390	2500 5000	CC-8	5 ⁵ / ₁₆	2750	1800

HIR/XL™ (ULTRA LONG LIFE) PAR38 LAMPS

45 WATTS

	45	PAR38	Med Skirt	40793	45PAR/HIR/SP12°/XL	120	6	Spotlight (15, 23, 56, 80, 88, 96)*	600	6000	CC-8	5 ⁵ / ₁₆	2680	4000
				40790	45PAR/HIR/FL40°/XL	120	6	Floodlight (15, 23, 56, 80, 88, 96)*	600	6000	CC-8	5 ⁵ / ₁₆	2680	1100

STANDARD HALOGEN PAR38 LAMPS

50 WATTS

	50	PAR38	Med Skirt	17980	50PAR/H/SP10°	120	6	Spotlight (56, 88, 96)*	590	2000	CC-8		2750	9000
				17979	50PAR/H/FL25°	120	6	Floodlight (56, 88, 96)*	590	2000	CC-8		2750	2200
	50			17926	50PAR/H/FL25°	130	12	Floodlight (56, 88, 96)* Ratings @ 120 Volts	590 450	2000 4000	CC-8		2750	2200

HALOGEN COMPACT PAR20 LAMPS

50 WATTS

	50	PAR20	Med NP	14927	50PAR20/H/SP10°	120	6	Spotlight (15, 55, 56, 80, 88)*	570	2500	CC-8	3 ¹ / ₈	2800	6000
	50			17866	50PAR20/H/SP10°	130	15	Spotlight (15, 55, 56, 80, 88)* Ratings @ 120 Volts	570 500	2500 5000	CC-8	3 ¹ / ₈	2800	6000
	46			14928	50PAR20H/FL25°	120	6	Floodlight (15, 55, 56, 80, 88)*	570	2500	CC-8	3 ¹ / ₈	2800	1500
	50			17868	50PAR20/H/FL25°	130	15	Floodlight (15, 55, 80, 88)* Ratings @ 120 Volts	570 500	2500 5000	CC-8	3 ¹ / ₈	2800	1500

HALOGEN COMPACT PAR30 LAMPS

50 WATTS

	50	PAR30	Med NP	14023	50PAR30/H/SP10°	120	6	Spotlight (15, 55, 56, 80, 88)*	610	3000	CC-8	3 ⁵ / ₈	2800	6900
	50			17870	50PAR30/H/SP10°	130	15	Spotlight (15, 55, 56, 80, 88)* Ratings @ 120 Volts	610 480	3000 6000	CC-8	3 ⁵ / ₈	2800	6900
	46			17871	50PAR30/H/FL25°	120	15	Floodlight (15, 55, 56, 80, 88)*	610	3000	CC-8	3 ⁵ / ₈	2800	2000
	50			17872	50PAR30/H/FL25°	130	15	Floodlight (15, 55, 56, 80, 88)* Ratings @ 120 Volts	610 480	3000 6000	CC-8	3 ⁵ / ₈	2800	2000
	46			14022	50PAR30/H/FL35°	120	6	Floodlight (15, 55, 56, 80, 88)*	610	3000	CC-8	3 ⁵ / ₈	2800	1400

50			17874	50PAR30/H/FL35°	130	15	Floodlight (15, 55, 56, 80, 88)* Ratings @ 120 Volts	610 480	3000 6000	CC-8	3 ⁵ / ₈	2800	1400
----	--	--	--------------	------------------------	-----	----	---	------------	--------------	------	-------------------------------	------	------



Watts	Bulb	Base	Product Code	Lamp Description	Case Volts	Qty.	Additional Information	Lumens	Rated Avg. Life Hours	Filament Design	MOL in.	LCL in.	Temp. K	Color CBCP
HALOGEN COMPACT PAR30 LONG NECK LAMPS														
50 WATTS														
		50 PAR30 Med NP	14940	50PAR30L/H/SP10°	120	6	Spotlight (15, 55)*	580 460	3000 6000	CC-8	4 ³ / ₄		2800	7000
		50 46	11117	50PAR30L/H/SP10°	130	15	Spotlight (15, 55)* Ratings @ 120 Volts	580 460	3000 6000	CC-8	4 ³ / ₄		2800	7000
			11116	50PAR30L/H/FL40°	120	15	Floodlight (15, 55)*	580	3000	CC-8	4 ³ / ₄		2800	1000
		50 46	11123	50PAR30L/H/FL40°	130	15	Floodlight (15, 55)* Ratings @ 120 Volts	580 460	3000 6000	CC-8	4 ³ / ₄		2800	1000
			14941	50PAR30L/H/WFL	120	6	Wide Flood (15, 55)*	630	3000	CC-8	4 ³ / ₄		2800	—
COMPACT HIR™ PAR30 LAMPS														
50 WATTS														
		50 PAR30 Med NP	19902	➔ 50PAR30/HIR/SP9°	120	15	Spotlight (15, 55, 56, 80, 88)*	770	3000	CC-8	3 ⁵ / ₈		2810	13000
		50 46	21534	➔ 50PAR30/HIR/SP9°	130	15	Spotlight (15, 55, 56, 80, 88)* Ratings @ 120 Volts	770 570	3000 6000	CC-8	3 ⁵ / ₈		2810	13000
			19901	➔ 50PAR30/HIR/FL25°	120	15	Floodlight (15, 55, 56, 80, 88)*	770	3000	CC-8	3 ⁵ / ₈		2810	2700
		50 46	21533	➔ 50PAR30/HIR/FL25°	130	15	Floodlight (15, 55, 56, 80, 88)* Ratings @ 120 Volts	770 570	3000 6000	CC-8	3 ⁵ / ₈		2810	2700
			19900	➔ 50PAR30/HIR/FL35°	120	15	Floodlight (15, 55, 56, 80, 88)*	770	3000	CC-8	3 ⁵ / ₈		2810	1500
		50 46	19903	➔ 50PAR30/HIR/FL35°	130	15	Floodlight (15, 55, 56, 80, 88)* Ratings @ 120 Volts	770 570	3000 6000	CC-8	3 ⁵ / ₈		2810	1500
HALOGEN PAR36 LAMPS														
		50 PAR36 Scrw Term	19878	50PAR36/H/SP5°	12	12	Spotlight (15)*	400	4000	C-6	2 ³ / ₄		3050	35000
			19879	50PAR36/H/SP8°	12	12	Spotlight (15)*	400	4000	C-6	2 ³ / ₄		3050	30000
			19880	50PAR36/H/FL30°	12	12	Floodlight (15)*	400	4000	C-6	2 ³ / ₄		3050	1300
HIR™ PAR38 LAMPS														
50 WATTS														
		50 PAR38 Med Skirt	12396	➔ 50PAR/HIR/SP10°	120	12	Spotlight (15, 23, 56, 80, 88, 96)*	850	3000	CC-8	5 ⁵ / ₁₆		2810	14000
		50 46	22843	➔ 50PAR/HIR/SP10°	130	12	Spotlight (15, 23, 56, 80, 88, 96)* Ratings @ 120 Volts	850 600	3000 6000	CC-8	5 ⁵ / ₁₆		2810	14000
			12397	➔ 50PAR/HIR/FL25°	120	12	Floodlight (15, 23, 56, 80, 88, 96)*	850	3000	CC-8	5 ⁵ / ₁₆		2810	3000
		50 46	22850	➔ 50PAR/HIR/FL25°	130	12	Floodlight (15, 23, 56, 80, 88, 96)* Ratings @ 120 Volts	850 600	3000 6000	CC-8	5 ⁵ / ₁₆		2810	3000
HALOGEN A-LINE LAMPS														
50 WATTS														
		50 TB19 Med	20647	50A/HAL 6PK	120	6	Frost, Brass Base (15, 23, 56, 83, 88)*	710	2000	CC-8	4 ⁷ / ₁₆	3 ¹ / ₈	2800	
		50 46	16747	50A/HAL	130	60	Frost, Brass Base (15, 23, 56, 83, 88)* Ratings @ 120 Volts	710 540	2000 4000	CC-8	4 ⁷ / ₁₆	3 ¹ / ₈	2800	
HIR/XL™ (ULTRA LONG LIFE) PAR38 LAMPS														
55 WATTS														
		55 PAR38 Med Skirt	40794	➔ 55PAR/HIR/SP12°/XL	120	6	Spotlight (15, 23, 56, 80, 88, 96)*	780	6000	CC-8	5 ⁵ / ₁₆		2680	9000
			40792	➔ 55PAR/HIR/FL40°/XL	120	6	Floodlight (15, 23, 56, 80, 88, 96)*	780	6000	CC-8	5 ⁵ / ₁₆		2680	2000

Halogen Lamps



Watts	Bulb	Base	Product Code	Lamp Description	Case Volts	Qty.	Additional Information	Rated Lumens	Avg. Life Hours	Filament Design	MOL in.	LCL in.	Color Temp. K	CBCP
-------	------	------	--------------	------------------	------------	------	------------------------	--------------	-----------------	-----------------	---------	---------	---------------	------

HALOGEN LONG LIFE PAR38 LAMPS

60 WATTS

	60	PAR38 Med Skirt	25266	60PAR/H/SP10°	120	12	Spotlight (15, 23, 46, 56, 83, 88)*	800	3000	CC-8	5 ⁵ / ₁₆	2800	13000
			25270	60PAR/H/SP10°	130	12	Spotlight (15, 23, 46, 56, 83, 88)* Ratings @ 120 Volts	800 610	3000 6000	CC-8	5 ⁵ / ₁₆	2800	13000
			25269	60PAR/H/FL25°	120	12	Floodlight (15, 23, 56, 83, 88, 96)*	800	3000	CC-8	5 ⁵ / ₁₆	2800	2800
			25271	60PAR/H/FL25°	130	12	Floodlight (15, 23, 56, 83, 88, 96)* Ratings @ 120 Volts	800 610	3000 6000	CC-8	5 ⁵ / ₁₆	2800	2800

HALOGEN COMPACT PAR30 LAMPS

	60	PAR30 Med	27212	60PAR30/H/SP10°	120	15	Spotlight (15, 55, 80, 88)*	800	3000	CC-8	3 ⁵ / ₈	2800	10000
			40167	60PAR30/H/FL25°	120	15	Floodlight (15, 55, 80, 88)*	800	3000	CC-8	3 ⁵ / ₈	2800	2400
			27214	60PAR30/H/FL35°	120	15	Floodlight (15, 55, 80, 88)*	800	3000	CC-8	3 ⁵ / ₈	2800	1700

HIR™ PAR38 LAMPS

60 WATTS

	60	PAR38 Med Skirt	18627	➔ 60PAR/HIR/SP10°	120	12	Spotlight (15, 23, 56, 88, 96)*	1110	3000	CC-8	5 ⁵ / ₁₆	2875	20000
			18629	➔ 60PAR/HIR/SP10°	130	12	Spotlight (15, 23, 56, 88, 96)* Ratings @ 120 Volts	1110 780	3000 6000	CC-8	5 ⁵ / ₁₆	2875	20000
	60	Med	23227	➔ 60PAR/HIR/SP12°	120	12	Spotlight (15, 23, 56, 88, 96)*	1110	3000	CC-8	5 ⁵ / ₁₆	2875	12000
	60	PAR38 Med Skirt	18626	➔ 60PAR/HIR/FL30°	120	12	Floodlight (15, 23, 56, 88, 96)*	1110	3000	CC-8	5 ⁵ / ₁₆	2875	3600
			18628	➔ 60PAR/HIR/FL30°	130	12	Floodlight (15, 23, 56, 88, 96)* Ratings @ 120 Volts	1110 780	3000 6000	CC-8	5 ⁵ / ₁₆	2875	3600
			10467	➔ 60PAR/HIR/FL40°	120	12	Floodlight (15, 23, 56, 88, 96)*	1110	3000	CC-8	5 ⁵ / ₁₆	2875	2000
			20947	➔ 60PAR/HIR/WFL	120	12	Wide Floodlight (15, 23, 56, 88, 96)*	1110	3000	CC-8	5 ⁵ / ₁₆	2875	—
	60		20948	➔ 60PAR/HIR/WFL	130	12	Wide Floodlight (15, 23, 56, 88, 96)* Ratings @ 120 Volts	1110 780	3000 6000	CC-8	5 ⁵ / ₁₆	2875	—

HALOGEN COMPACT PAR30 LAMPS

75 WATTS

	75	PAR30 Med NP	14802	75PAR30/H/SP10°	120	6	Spotlight (15, 55, 56, 80, 88)*	1030	3000	CC-8	3 ⁵ / ₈	2830	13000
			18056	75PAR30/H/SP10°	130	15	Spotlight (15, 55, 56, 80, 88)* Ratings @ 120 Volts	1030 790	3000 6000	CC-8	3 ⁵ / ₈	2830	13000
			18057	75PAR30/H/FL25°	120	15	Floodlight (15, 55, 56, 80, 88)*	1030	3000	CC-8	3 ⁵ / ₈	2830	3100
			14779	75PAR30/H/FL35°	120	6	Floodlight (15, 55, 56, 80, 88)*	1030	3000	CC-8	3 ⁵ / ₈	2830	2000
	75		18060	75PAR30/H/FL35°	130	15	Floodlight (15, 55, 56, 80, 88)* Ratings @ 120 Volts	1030 790	3000 6000	CC-8	3 ⁵ / ₈	2830	2000

HALOGEN COMPACT PAR30 LONG NECK LAMPS

75 WATTS

	75	PAR30 Med NP	11124	75PAR30L/H/SP10°	120	15	Spotlight (15, 55)*	940	3000	CC-8	4 ³ / ₄	2830	9000
			11129	75PAR30L/H/SP10°	130	15	Spotlight (15, 55)* Ratings @ 120 Volts	940 750	3000 6000	CC-8	4 ³ / ₄	2830	9000
			14943	75PAR30L/H/FL25°	120	6	Floodlight (15, 55)*	940	3000	CC-8	4 ³ / ₄	2830	3100
	75		11131	75PAR30L/H/FL25°	130	15	Floodlight (15, 55)* Ratings @ 120 Volts	940 750	3000 6000	CC-8	4 ³ / ₄	2830	3100
	66		16393	75PAR30L/H/WFL	120	6	Wide Floodlight (15, 55)*	1050	3000	CC-8	4 ³ / ₄	2830	—

To save energy costs, find the bulbs with the light output you need, then choose the one with the lowest watts.

(*) * All footnote references found at the end of this section. ➔ Reduced Wattage. To convert inches to millimeters, multiply by 25.4.

Halogen Lamps



Watts	Bulb	Base	Product Code	Lamp Description	Case Volts	Qty.	Additional Information	Lumens	Rated Avg. Life Hours	Filament Design	MOL in.	LCL in.	Temp. K	Color CBCP
HALOGEN LONG LIFE PAR38 LAMPS														
75 WATTS														
	75	PAR38	Med Skirt	14751	75PAR/H/SP9°	120	6	Spotlight (15, 23, 46, 56, 88, 96)*	1030	2500	CC-8	5 ⁵ / ₁₆	2850	18000
				14748	75PAR/H/FL25°	120	6	Floodlight (15, 23, 46, 56, 88, 96)*	1030	2500	CC-8	5 ⁵ / ₁₆	2850	4000
	75 66			21389	75PAR/H/FL25°	130	12	Floodlight (15, 23, 46, 56, 88, 96)* Ratings @ 120 Volts	1030 800	2500 5000	CC-8	5 ⁵ / ₁₆	2850	4000
HIR™ PAR38 LAMPS														
80 WATTS														
	80	PAR38	Med Skirt	27216	80PAR/HIR/SP10°	120	12	Spotlight (15, 23, 46, 56, 88, 96)*	1500	3000	CC-8	5 ⁵ / ₁₆	2900	25000
				27217	80PAR/HIR/SP12°	120	12	Spotlight (15, 23, 46, 56, 88, 96)*	1500	3000	CC-8	5 ⁵ / ₁₆	2900	19000
				27218	80PAR/HIR/FL25°	120	12	Floodlight (15, 23, 46, 56, 88, 96)*	1500	3000	CC-8	5 ⁵ / ₁₆	2900	5500
HALOGEN LONG LIFE PAR38 LAMPS														
90 WATTS														
	90	PAR38	Med Skirt	17450	90PAR/H/SP10°	120	6	Spotlight (14, 15, 23, 56, 88, 96)*	1260	2500	CC-8	5 ⁵ / ₁₆	2870	16000
	90			13311	90PAR/H/SP10°	130	12	Spotlight (14, 15, 56, 88)* Ratings @ 120 Volts	1260 940	2000 5000	CC-8	5 ⁵ / ₁₆	2870	16000
	79			17451	90PAR/H/FL25°	120	6	Floodlight (15, 23, 46, 56, 88, 96)*	1260	2500	CC-8	5 ⁵ / ₁₆	2870	4100
	90			13308	90PAR/H/FL25°	130	12	Floodlight (15, 23)* Ratings @ 120 Volts	1260 940	2500 5000	CC-8	5 ⁵ / ₁₆	2870	4100
	79			25727	90PAR/H/WFL	120	12	Wide Floodlight (15, 23, 46, 56, 88, 96)*	1260	2500	CC-8	5 ⁵ / ₁₆	2870	—
HIR/XL™ (ULTRA LONG LIFE) PAR38 LAMPS														
90 WATTS														
	90	PAR38	Med Skirt	40795	90PAR/HIR/SP12°/XL	120	6	Spotlight (15, 23, 56, 80, 88, 96)*	1470	6000	CC-8	5 ⁵ / ₁₆	2800	12000
				40791	90PAR/HIR/FL40°/XL	120	6	Floodlight (15, 23, 56, 80, 88, 96)*	1470	6000	CC-8	5 ⁵ / ₁₆	2800	2800
HALOGEN COOL BEAM PAR38 LAMPS														
	90	PAR38	Med Skirt	17691	90PAR/CB/H/FL25°	120	12	Cool Beam Flood (15, 23, 78)*	1260	2500	CC-8	5 ⁵ / ₁₆	2870	4100
HALOGEN A-LINE LAMPS														
90 WATTS														
	90	TB19	Med	20648	90A/HAL 6PK	120	6	Frost, Brass Base (23, 83, 88)*	1580	2000	CC-8	4 ⁷ / ₁₆	3 ¹ / ₈	2930
	90 81			16745	90A/HAL	130	60	Frost, Brass Base (23, 83, 88)* Ratings @ 120 Volts	1580 1220	2000 4000	CC-8	4 ⁷ / ₁₆	3 ¹ / ₈	2930
STANDARD HALOGEN PAR38 LAMPS														
100 WATTS														
	100	PAR38	Med Skirt	17992	100PAR/H/SP10°	120	6	Spotlight (14, 15, 56, 88)*	1400	2000	CC-8	5 ⁵ / ₁₆	2900	17000
				17986	100PAR/H/FL25°	120	6	Floodlight (14, 15, 56, 88)*	1400	2000	CC-8	5 ⁵ / ₁₆	2900	4800
	100 88			17947	100PAR/H/FL25°	130	12	Floodlight (14, 15, 56, 88)* Ratings @ 120 Volts	1400 1100	2000 4000	CC-8	5 ⁵ / ₁₆	2900	4800
HIR™ PAR38 LAMPS														
100 WATTS														
	100	PAR38	Med Skirt	18635	100PAR/HIR/SP10°	120	12	Spotlight (15, 23, 56, 88, 96)*	2070	3000	CC-8	5 ⁵ / ₁₆	2900	29000
	100			18636	100PAR/HIR/SP10°	130	12	Spotlight (15, 23, 56, 88, 96)* Ratings @ 120 Volts	2070 1470	3000 6000	CC-8	5 ⁵ / ₁₆	2900	29000
	88			18631	100PAR/HIR/FL25°	120	12	Floodlight (15, 23, 56, 88, 96)*	2070	3000	CC-8	5 ⁵ / ₁₆	2900	6300
	100			18633	100PAR/HIR/FL25°	130	12	Floodlight (15, 23, 56, 88, 96)* Ratings @ 120 Volts	2070 1470	3000 6000	CC-8	5 ⁵ / ₁₆	2900	6300
	88			10473	100PAR/HIR/FL40°	120	12	Floodlight (23, 56, 88, 96)*	2070	3000	CC-8	5 ⁵ / ₁₆	2900	3400



Watts	Bulb	Base	Product Code	Lamp Description	Case Volts	Qty.	Additional Information	Rated		Color			
								Lumens	Avg. Life Hours	Flament Design	MOL in.	LCL in.	Temp. K
QUARTZLINE® PAR38 LAMPS													
250	PAR38	Med Skirt	23719	Q250PAR/SP10°	120	12	Spotlight (96a, 96b, 112)*	3600	4200	CC-8	5 ⁵ / ₁₆	2880	40000
			23718	Q250PAR/FL30°	120	12	Floodlight (96a, 96b, 112, 120)*	3600	4200	CC-8	5 ⁵ / ₁₆	2880	9000
TURN AND LOCK (TAL) CONSTANTCOLOR® LAMPS													
50 WATTS													
50	MR16	TAL	30901	50MR16/Q/10°/TL	12	10	Narrow Spot (132)*	3500		C-6	2	3000	10800
			30900	50MR16/Q/20°/TL	12	10	Narrow Flood (132)*	3500		C-6	2	3000	3330
			30899	50MR16/Q/40°/TL	12	10	Flood (132)*	3500		C-6	2	3000	1395
STANDARD MR11 LAMPS													
20-35 WATTS													
20	MR11	2-Pin G4	30754	Q20MR11/SP15°-FTC	12	10	Spot (132)*	3500		C-6	1 ³ / ₈	2900	1760
			30773	Q20MR11/NFL30°-FTD	12	10	Narrow Flood (132)*	3500		C-6	1 ³ / ₈	2900	600
35	MR11	2-Pin G4	30774	Q35MR11/SP20°-FTF	12	10	Spot (132)*	3500		C-6	1 ³ / ₈	2900	3000
			30890	Q35MR11/NFL30°-FTH	12	10	Narrow Flood (132)*	3500		C-6	1 ³ / ₈	2900	1300
STANDARD MR16 LAMPS													
20	MR16	2-Pin GX5.3	25481	Q20MR16/SP	12	20	Spot, Replacement for ESX (132)*	2000		C-6	1 ⁷ / ₈	2900	3500
			25480	Q20MR16/FL	12	20	Flood, Replacement for BAB (132)*	2000		C-6	1 ⁷ / ₈	2900	500
50	MR16	2-Pin GX5.3	25483	Q50MR16/SP	12	20	Spot, Replacement for EXT (132)*	2000		C-6	1 ⁷ / ₈	2900	9500
			25482	Q50MR16/FL	12	20	Flood, Replacement for EXN (132)*	2000		C-6	1 ⁷ / ₈	2900	1500
CONSTANTCOLOR® PRECISE™ MR16 LAMPS													
20-71 WATTS													
20	MR16	2-Pin GX5.3	20816	Q20MR16/C/VNSP7°-EZ 10PK	12	20	Very Narrow Spot (132)*	3000		CC-6	1 ⁷ / ₈	2900	7400
			20815	Q20MR16/C/NSP15°-ESX 10PK	12	20	Narrow Spot (132)*	5000		C-6	1 ⁷ / ₈	2900	3750
			20814	Q20MR16/C/FL40°-BAB 10PK	12	20	Flood (132)*	5000		C-6	1 ⁷ / ₈	2900	525
35	MR16	2-Pin GX5.3	20826	Q35MR16/C/SP20°-FRA 10PK	12	20	Spot (132)*	5000		C-6	1 ⁷ / ₈	3000	3900
			20825	Q35MR16/C/FL40°-FMW 10PK	12	20	Flood (132)*	5000		C-6	1 ⁷ / ₈	3000	1000
42	MR16	2-Pin GX5.3	20830	Q42MR16/C/VNSP9°-EZY 10PK	12	20	Very Narrow Spot (132)*	3500		CC-6	1 ⁷ / ₈	3000	12300
50	MR16	2-Pin GX5.3	20839	Q50MR16/C/NSP15°-EXT 10PK	12	20	Narrow Spot (132)*	6000		C-6	1 ⁷ / ₈	3050	9100
			20835	Q50MR16/C/NFL25°-EXZ 10PK	12	20	Narrow Flood (132)*	6000		C-6	1 ⁷ / ₈	3050	3200
			20834	Q50MR16/C/NFL30°-EXK 10PK	12	20	Narrow Flood (132)*	6000		C-6	1 ⁷ / ₈	3050	2500
			20833	Q50MR16/C/FL40°-EXN 10PK	12	20	Flood (132)*	6000		C-6	1 ⁷ / ₈	3050	1700
			20832	Q50MR16/C/WFL55°-FNV 10PK	12	20	Wide Flood (132)*	6000		C-6	1 ⁷ / ₈	3050	900
			71	MR16	2-Pin GX5.3	20843	Q71MR16/C/NSP15°-EYF 10PK	12	20	Narrow Spot (132)*	4000		C-6
			20841	Q71MR16/C/NFL25°-EYJ 10PK	12	20	Narrow Flood (132)*	4000		C-6	1 ⁷ / ₈	3050	5500
			20840	Q71MR16/C/FL40°-EYC 10PK	12	20	Flood (132)*	4000		C-6	1 ⁷ / ₈	3050	2200

To save energy costs, find the bulbs with the light output you need, then choose the one with the lowest watts.

(*) * All footnote references found at the end of this section. Reduced Wattage. To convert inches to millimeters, multiply by 25.4.



Watts	Bulb	Base	Product Code	Lamp Description	Case Volts	Qty.	Additional Information	Rated Avg. Life Hours	Filament Design	MOL in.	LCL Temp. K	Color CBCP
CONSTANTCOLOR® PRECISE™ COVER GLASS MR16 LAMPS												
20-71 WATTS												
20	MR16	2-Pin GX5.3	20858	Q20MR16/C/CG15°-ESX 10PK	12	20	Narrow Spot, Clear Glass Protective Lens, Suitable for Use in Open Fixtures (132)*	5000	C-6	1 7/8	2900	3150
			20857	Q20MR16/C/CG40°-BAB 10PK	12	20	Flood, Clear Glass Protective Lens, Suitable for Use in Open Fixtures (132)*	5000	C-6	1 7/8	2900	475
35	MR16	2-Pin GU5.3	20864	Q35MR16/C/CG12°-FRB	12	20	Narrow Spot, Clear Glass Protective Lens, Suitable for Use in Open Fixtures (132)*	5000	C-6	1 7/8	3000	7500
35	MR16	2-Pin GX5.3	20860	Q35MR16/C/CG20°-FRA 10PK	12	20	Spot, Clear Glass Protective Lens, Suitable for Use in Open Fixtures (132)*	5000	C-6	1 7/8	3000	3200
			20859	Q35MR16/C/CG40°-FMW 10PK	12	20	Flood, Clear Glass Protective Lens, Suitable for Use in Open Fixtures (132)*	5000	C-6	1 7/8	3000	900
50	MR16	2-Pin GX5.3	20872	Q50MR16/C/CG15°-EXT 10PK	12	20	Narrow Spot, Clear Glass Protective Lens, Suitable for Use in Open Fixtures (132)*	6000	C-6	1 7/8	3050	8400
			20871	Q50MR16/C/CG25°-EXZ 10PK	12	20	Narrow Flood, Clear Glass Protective Lens, Suitable for Use in Open Fixtures (132)*	6000	C-6	1 7/8	3050	2900
			20867	Q50MR16/C/CG40°-EXN 10PK	12	20	Flood, Clear Glass Protective Lens, Suitable for Use in Open Fixtures (132)*	6000	C-6	1 7/8	3050	1500
			20865	Q50MR16/C/CG55°-FNV 10PK	12	20	Wide Flood, Clear Glass Protective Lens, Suitable for Use in Open Fixtures (132)*	6000	C-6	1 7/8	3050	850
71	MR16	2-Pin GX5.3	20876	Q71MR16/C/CG15°-EYF 10PK	12	20	Narrow Spot, Clear Glass Protective Lens, Suitable for Use in Open Fixtures (132)*	4000	C-6	1 7/8	3050	10800
			20874	Q71MR16/C/CG25°-EYJ 10PK	12	20	Narrow Flood, Clear Glass Protective Lens, Suitable for Use in Open Fixtures (132)*	4000	C-6	1 7/8	3050	4550
			20873	Q71MR16/C/CG40°-EYC 10PK	12	20	Flood, Clear Glass Protective Lens, Suitable for Use in Open Fixtures (132)*	4000	C-6	1 7/8	3050	2000

QUARTZ HALOGEN LAMPS

5-100 WATTS

5	T3	2-Pin G4	42959	Q5T3/CL	12	100	Clear (132)*	60	2000	C-6	1 1/4	3/4
			34674	Q10T3/CL	12	100	Clear (132)*	140	2000	C-6	1 1/4	3/4
10	T3	2-Pin G4	19371	Q10T3/CL/CD 5PK	12	25	Clear. Carded (132)*	140	2000	C-6	1 1/4	3/4
			34715	Q20T2.5/12V/CL	12	100	(132)*	350	2000	C-6	1 1/4	3/4
20	T3	2-Pin G4	19375	Q20T3/CL/CD 5PK	12	25	Clear. Carded (132)*	350	2000	C-6	1 1/4	3/4
35	T3	2-Pin GY6.35	34708	Q35T3/12V/CL	12	100	(132)*	550	2000	C-6	1 3/4	
50	T3	2-Pin GY6.35	34702	Q50T3/12V/CL	12	100	(132)*	850	2000	C-6	1 3/4	
50	T4	2-Pin GY6.35	19376	Q50T4/CL/CD 5PK	12	25	Clear. Carded (132)*	950	2000	C-6	1 3/4	1 1/8
75	T4	2-Pin GY6.35	19377	Q75T4/CL/CD 5PK	12	25	Clear. Carded (132)*	1600	2000	C-6	1 3/4	1 1/8
100	T3	2-Pin GY6.35	34676	Q100T3/12V/CL	12	100	(132)*	2350	2000	CC-6	1 3/4	
			34663	Q100T3/24V/CL	24	100	(132)*	2000	2000	CC-6	1 3/4	



Watts	Bulb	Base	Product Code	Lamp Description	Case Volts	Qty.	Additional Information	Lumens	Rated Avg. Life Hours	Filament Design	MOL in.	LCL in.	Color Temp. K	CBCP
-------	------	------	--------------	------------------	------------	------	------------------------	--------	-----------------------	-----------------	---------	---------	---------------	------

QUARTZLINE® HALOGEN LAMPS

45-75 WATTS

	45 T2 ^{1/2}	R7S	23850	Q45T21/2/CL	7	12	Clear, Instrument (137)*	710	1000	C-8	2 ¹ / ₁₆			
	45 T4	2-Pin PreFoc	41541	Q45T4/CL	6.6A	12	Clear, Airport, Base Down	835	500	C-6	2 ¹ / ₂	1 ¹⁷ / ₃₂		
	75 T3	Mini-Cand	39574	Q75CL	28	20	Clear	1350	2000	CC-6	2 ¹ / ₂	1 ³ / ₁₆		
			12715	Q75CL/MC/CD	120	25	Clear, Carded	1050	1000	CC-8	2 ¹ / ₂	1 ¹ / ₄	2850	

100 WATTS

	100 T3	R7S	22489	Q100T3/CL/CD 5PK	120	60	Clear, Horizontal, Carded	1650	1500	C-8	3 ¹ / ₈	1 ¹ / ₄	2950	
	100 T4	Mini-Cand	15507	Q100CL/MC	120	6	Clear	1600	2000	CC-8	2 ¹³ / ₁₆	1 ³ / ₈	2950	
			19383	Q100CL/MC/CD 5PK	120	25	Clear, Carded	1600	2000	CC-8	2 ¹³ / ₁₆	1 ³ / ₈	2950	
			44385	Q100CL/MC/2V-ESN	120	6	Clear	1800	750	CC-2V	2 ¹³ / ₁₆	1 ³ / ₈	2950	
			16452	Q100MC	120	6	Frosted	1550	2000	CC-8	2 ¹³ / ₁₆	1 ³ / ₈	2950	
			44656	Q100MC/2V-ETE	120	6	Frosted	1750	750	CC-2V	2 ¹³ / ₁₆	1 ³ / ₈	2950	
	100 T4	D.C. Bay	15508	Q100CL/DC	120	6	Clear	1600	2000	CC-8	2 ¹ / ₁₆	1 ³ / ₈	2950	
			44386	Q100CL/DC/2V-ESR	120	6	Clear	1800	750	CC-2V	2 ¹ / ₁₆	1 ³ / ₈	2950	
			16451	Q100DC	120	6	Frosted	1550	2000	CC-8	2 ¹ / ₁₆	1 ³ / ₈	2950	
			44657	Q100DC/2V-ETD	120	6	Frosted	1750	750	CC-2V	2 ¹ / ₁₆	1 ³ / ₈	2950	

150 WATTS

	150 T3	R7S	19378	Q150T3/CL/CD 5PK	120	60	Clear, Horizontal, Carded	2400	1500	C-8	3 ¹ / ₈	1 ¹ / ₄	2950	
			27449	Q150T3/117/CL/CD 5PK	120	60	Clear, Horizontal, Carded	2400	1500	C-8	3 ¹ / ₈	1 ¹ / ₄	2950	
	150 T4	R7S	23710	Q150T4/CL	25	12	Clear, Dental Spotlight (139)*	2760	3000	CC-8	2 ⁹ / ₁₆		2850	
	150 T4	D.C. Bay	43693	Q150CL/DC-ETC	120	6	Clear	2800	2000	CC-8	2 ¹ / ₂	1 ³ / ₈	2950	
			44384	Q150CL/DC/2V-ESP	120	6	Clear	2800	1000	CC-2V	2 ¹ / ₁₆	1 ³ / ₈	2950	
			44653	Q150DC-ETF	120	6	Frosted	2700	2000	CC-8	2 ¹ / ₂	1 ³ / ₈	2950	
	150 T4	Mini-Cand	43694	Q150CL/MC-ETG	120	6	Clear	2800	2000	CC-8	3	1 ³ / ₈	2950	
			19386	Q150CL/MC/CD 5PK	120	25	Clear, Carded	2800	2000	CC-8	3	1 ³ / ₈	2950	
			44383	Q150CL/MC/2V-ESL	120	6	Clear	2800	1000	CC-2V	2 ¹³ / ₁₆	1 ³ / ₈	2950	
			44654	Q150MC-ETH	120	6	Frosted	2700	2000	CC-8	3	1 ³ / ₈	2950	

200 WATTS

	200 T3	R7S	16580	Q200T3 6PK	120	6	Frosted (100)*3350		1500	CC-8	3 ¹ / ₈	1 ¹ / ₄	2925	
			43713	Q200T3/CL 6PK	120	144	Clear	3460	1500	CC-8	3 ¹ / ₈	1 ¹ / ₄	2925	
	200 T4	2-Pin PreFoc	40702	Q200T4/CL	6.6A	12	Clear, Airport, Base Down	4500	500	CC-6	2 ¹ / ₂	1 ¹⁷ / ₃₂		

QUARTZLINE® HIR™ LAMPS

225 WATTS

	225 T2	R7S	12282	Q225T2/CL/ULTRA 5PK	120	25	IR, Clear, Horizontal	5950	3000	C-8	4 ¹¹ / ₁₆	2 ¹ / ₂	2965	
--	--------	-----	-------	---------------------	-----	----	-----------------------	------	------	-----	---------------------------------	-------------------------------	------	--

Halogen Lamps



Watts	Bulb	Base	Product Code	Lamp Description	Case Volts	Qty.	Additional Information	Lumens	Rated Avg. Life Hours	Filament Design	MOL in.	LCL in.	Color Temp. K	CBCP
QUARTZLINE® HALOGEN LAMPS														
235 WATTS														
	235 T4	2-Pin GZ9.5	11548	Q235T4/3	33	12	Frosted, Instrument, Prefocus (103)*	6000	150	CC-6	2 ⁵ / ₈	1 ¹⁷ / ₃₂		
250 WATTS														
	250 T3	R7S	22865	Q250T3/CL 6PK	120	144	Clear, Horizontal	4000	1500	C-8	3 ¹ / ₈	1 ¹ / ₄	2950	
	250 T2 ¹ / ₂	R7S	22121	Q250T3/CL/CD 5PK CARD	120	60	Clear, Carded	4000	1500	C-8	3 ¹ / ₄	1 ¹ / ₈	2950	
	250 T4	D. C. Bay	43701	Q250DC-ETB	120	6	Frosted	4850	2000	CC-8	3	1 ⁵ / ₈	2950	
			43702	Q250DC	130	6	Frosted	4850	2000	CC-8	3	1 ⁵ / ₈	2950	
	250 T4	Mini-Cand	43695	Q250MC-ESM	120	6	Frosted	4850	2000	CC-8	3 ⁵ / ₃₂	1 ⁵ / ₈	2950	
			43696	Q250MC	130	6	Frosted	4850	2000	CC-8	3 ⁵ / ₃₂	1 ⁵ / ₈	2950	
	250 T4	D.C. Bay	43697	Q250CL/DC-ESS	120	6	Clear	5000	2000	CC-8	3	1 ⁵ / ₈	2950	
			43698	Q250CL/DC	130	6	Clear	5000	2000	CC-8	3	1 ⁵ / ₈	2950	
	250 T4	Mini-Cand	43699	Q250CL/MC-EHT	120	6	Clear	5000	2000	CC-8	3 ⁵ / ₃₂	1 ⁵ / ₈	2950	
			19387	Q250CL/MC/CD 5PK	120	25	Clear, Carded	5000	2000	CC-8	3 ⁵ / ₃₂	1 ⁵ / ₈	2950	
			43700	Q250CL/MC	130	6	Clear	5000	2000	CC-8	3 ⁵ / ₃₂	1 ⁵ / ₈	2950	
300 WATTS														
	300 T3	R7S	43704	Q300T3-EHZ 6PK	120	144	Frosted, Horizontal	5900	2000	C-8	4 ¹¹ / ₁₆	2 ¹ / ₄	2950	
	300 T2 ¹ / ₂	R7S	19379	Q300T3/CL/CD 5PK CARD	120	60	Clear, Horizontal, Carded	5950	2000	C-8	4 ¹¹ / ₁₆	2 ¹ / ₄	2950	
			27447	Q300T3/CL/CD2 5PK	120	60	Clear, Horizontal, Carded	5950	2000	C-8	4 ¹¹ / ₁₆	2 ¹ / ₄	2950	
	300 T3	R7S	43703	Q300T3/CL-EHM 6PK	120	144	Clear, Horizontal	5950	2000	C-8	4 ¹¹ / ₁₆	2 ¹ / ₄	2950	
	300 T4	R7S	43705	Q300T4/CL-EHP	120	6	Clear	5650	2000	CC-8	3 ¹ / ₈	2 ¹ / ₄	2900	
QUARTZLINE® HIR™ LAMPS														
350														
	350 T3	R7S	13894	Q350T3/CL/HIR	120	6	IR, Clear, Horizontal	10000	2000	C-8	4 ¹¹ / ₁₆	2 ¹ / ₄	3075	
			14311	Q350T3/CL/HIR	130	6	IR, Clear, Horizontal	9600	2000	C-8	4 ¹¹ / ₁₆	2 ¹ / ₄	3000	
			12283	Q350T3/CL/ULTRA 5PK	120	25	IR, Clear, Horizontal, Carded	10000	2000	C-8	4 ¹¹ / ₁₆	2 ¹ / ₄	3075	
QUARTZLINE® HALOGEN LAMPS														
400-425 WATTS														
	400 T4	Mini-Cand	43706	Q400MC	120	6	Frosted	7850	2000	CC-8	3 ⁵ / ₈	2	2950	
			43707	Q400CL/MC	120	6	Clear	8250	2000	CC-8	3 ⁵ / ₈	2	2950	
	400 T4	R7S	43708	Q400T4/CL-EHR	120	6	Clear	7750	2000	CC-8	3 ¹ / ₈	1 ¹³ / ₁₆	2900	
	425 T3	R7S	11178	Q425T3/CL	120	12	Clear, Horizontal	8900	2000	C-8	4 ¹¹ / ₁₆	2 ⁷ / ₃₂	3000	
500 WATTS														
	500 PAR56	Mog End Pr	43494	Q500PAR56NSP	120	6	Narrow Spot (106, 131)*	8000	4000	CC-6	5		2950	96000
			43495	Q500PAR56MFL	120	6	Medium Flood (106, 131)*	8000	4000	CC-6	5		2950	43000
			43496	Q500PAR56WFL	120	6	Wide Flood (106, 131)*	8000	4000	CC-6	5		2950	19000
	500 T3	R7S	23717	Q500T3 12PK	130	144	Frosted, Horizontal	10300	2000	C-8	4 ¹¹ / ₁₆	2 ¹ / ₄	3000	
			23731	Q500T3/CL-FCL	120	12	Clear, Horizontal	11100	2000	C-8	4 ¹¹ / ₁₆	2 ¹ / ₄	3000	
	500 T2 ¹ / ₂	R7S	19382	Q500T3/CL/CD 5PK CARD	120	60	Clear, Horizontal, Carded	11100	2000	C-8	4 ¹¹ / ₁₆	2 ¹ / ₄	3000	
			27448	Q500T3/CL/CD2 5PK	120	60	Clear, Horizontal, Carded	11100	2000	C-8	4 ¹¹ / ₁₆	2 ¹ / ₄	3000	
	500 T3	R7S	23733	Q500T3/CL-DVS	130	12	Clear, Horizontal	10550	2000	C-8	4 ¹¹ / ₁₆	2 ¹ / ₄	3000	
			23744	Q500T3/CL/6 12PK	120	144	Clear, 6 Filament Support, Rough Service, Horizontal (103, 133)*	10950	1500	C-8	4 ¹¹ / ₁₆	2 ¹ / ₄	3000	
	500 T4	D.C. Bay	43709	Q500DC	120	6	Frosted	10100	2000	CC-8	3 ⁷ / ₁₆	2 ¹ / ₈	2950	
	500 T4	D.C. Bay	43710	Q500CL/DC	120	6	Clear	10450	2000	CC-8	3 ⁷ / ₁₆	2 ¹ / ₈	2950	
	500 T8FL	Approx. 6" Flexible Leads	39071	Q500T8/1CL	20A	20	Clear, Airport, Special bulb (134)*	13400	500	CC-8	4 ¹ / ₄	2 ¹ / ₂		

Halogen Lamps



Watts	Bulb	Base	Product Code	Lamp Description	Case Volts Qty.	Additional Information	Rated Lumens	Rated Avg. Life Hours	Filament Design	MOL in.	LCL in.	Color Temp. K	CBCP
-------	------	------	--------------	------------------	-----------------	------------------------	--------------	-----------------------	-----------------	---------	---------	---------------	------





QUARTZLINE® HIR™ LAMPS

900 WATTS

	900 T3	R7S	13642	↔ Q900T3/CL/HIR	240 6	IR, Clear, Horizontal	32000	2000	C-8	10 ¹ / ₁₆	6 ¹ / ₈	3160	
			14335	↔ Q900T3/CL/HIR	277 6	IR, Clear, Horizontal	31000	2000	C-8	10 ¹ / ₁₆	6 ¹ / ₈	3160	

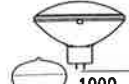
QUARTZLINE® HALOGEN LAMPS



1000 WATTS

	1000 PAR64	ExMogEndPr	43497	Q1000PAR64/NSP	120 6	Narrow Spot (106, 131)*	19400	4000	CC-6	6	3000	200000	
			43498	Q1000PAR64/MFL	120 6	Medium Flood (106, 131)*	19400	4000	CC-6	6	3000	80000	
			43499	Q1000PAR64/WFL	120 6	Wide Flood (106, 131)*	19400	4000	CC-6	6	3000	33000	
	1000 R60	Mog	23781	Q1000R60FL	120 6	Reflector, Flood I.F. (55, 108, 114, 172)*	18300	3000	CC-8	10 ¹ / ₈			
	1000 T3	R7S	43711	Q1000T3/CL 6PK	220 144	Clear, Horizontal	21500	2000	C-8	10 ¹ / ₁₆	6 ¹ / ₈	3050	
			43712	Q1000T3/CL 6PK	240 144	Clear, Horizontal	21500	2000	C-8	10 ¹ / ₁₆	6 ⁷ / ₁₆	3050	
	1000 T2	R7S	23800	Q1000T6/CL-DWT	120 6	Clear	23400	2000	CC-8	5 ⁵ / ₈	1	3200	
	1000 T20	Mog BiPost	41734	Q1000T20BP	120 6	Clear, Lighthouse, Base Down	22400	3000	CC-8	9 ¹ / ₂	4	3050	

1500 WATTS

	1500 T3	R7S	23828	Q1500T3/CL 12PK	208 144	Clear, Horizontal	35800	2000	C-8	10 ¹ / ₁₆	6 ⁹ / ₁₆	3050	
			23826	Q1500T3/CL 12PK	220 144	Clear, Horizontal	35800	2000	C-8	10 ¹ / ₁₆	6 ¹³ / ₁₆	3050	
			23830	Q1500T3/CL	240 12	Clear, Horizontal	35800	2000	C-8	10 ¹ / ₁₆	6 ⁵ / ₁₆	3050	
			23836	Q1500T3/CL/6 12PK	240 144	Clear, 14 Filament Support, Rough Service, Horizontal (100, 133)*	35800	1000	C-8	10 ¹ / ₁₆	6 ³ / ₄	3050	
			23832	Q1500T3/CL	277 12	Clear, Horizontal	34400	2000	C-8	10 ¹ / ₁₆	6 ⁹ / ₁₆	3050	

6000-6600 WATTS

	6000 T3	Wire Lead	23843	Q6M/T3/CL/HT	480 12	Clear, Infrared, High Temp, Constr. (103, 111, 122, 125)*		100	C-8	11 ¹⁵ / ₁₆	9 ³ / ₄	3250	
	6600 T3	Slv	13511	Q6000T3/CL	480 6	Clear, Infrared, Horizontal (100, 103, 111, 122, 125)*		150	C-8	11 ¹⁵ / ₁₆	9 ³ / ₄		

AIRPORT LAMPS LISTED BY AMPHERES

	200 PAR56	Mog End Pr	38271	Q6.6A/PAR56/2	200W 12	PAR, Airport, BDTH	1000		CC-6	5		16000	
	200 PAR56	Mog End Pr	18309	Q6.6A/PAR56/4	200W 12	PAR, Airport, Prismatic Lens, BDTH	600		CC-6	5			
	200 PAR56	Scrw Term	33279	Q6.6A/PAR56/3	200W 12	PAR, Airport, BDTH	1000		CC-6	4 ¹ / ₂		200000	
	200 PAR64	Mog End Pr	13224	Q6.6A/PAR64/2P 6PK	200W 6	PAR, Airport, BDTH	2000		CC-6	4 ¹ / ₂			
	300 PAR64	Mog End Pr	13223	Q6.6A/PAR64/3P 6PK	300W 6	PAR, Airport, BDTH	2000		CC-6	4 ¹ / ₂			
	45 T2 ¹ / ₂	Special	23847	Q6.6A/T21/2/1CL	45W 12	Clear, Airport (134, 137, 151, 161)*	710	1000	C-8	1 ³ / ₄			
	200 T4	Special 1" Ribbon Leads	23857	Q6.6A/T4/5CL	200W 12	Clear, Airport (134, 135, 175)*	5000	500	CC-8	3			
	200 T4	D.C. Bay	23860	Q6.6A/T4/DCR	200W 12	Clear, Airport, Ringed (129)*	5150	500	CC-6	2 ¹ / ₂	1 ¹ / ₁₆		
	300 PAR56	Mog End Pr	15482	Q20A/PAR56/C	300W 12	PAR, Airport, Teflon® Coated, Burn Position: Any (113)*		500	CC-6	5			
	300 PAR56	Scrw Term	32861	Q20A/PAR56/2	300W 12	PAR, Airport, Burn Position: Any		500	CC-6	4 ¹ / ₂		200000	
	499 PAR56	Scrw Term	23863	Q20A/PAR56/3	499W 12	PAR, Airport, BDTH		500	CC-6	4 ¹ / ₂		330000	
	500 PAR56	Mog End Pr	15485	Q20A/PAR56/1/C	500W 12	PAR, Airport, Teflon® Coated, Burn Position: Any (113)*		500	CC-6	5			

To save energy costs, find the bulbs with the light output you need, then choose the one with the lowest watts.
 (*) * All footnote references found at the end of this section. ↔ Reduced Wattage. To convert inches to millimeters, multiply by 25.4.



Watts	Bulb	Base	Product Code	Lamp Description	Case Volts	Qty.	Additional Information	Lumens	Rated Avg. Life Hours	Filament Design	MOL in.	LCL in.	Color Temp. K	GBCP
TUBULAR QUARTZ HEAT LAMPS														
300-375 WATTS														
	300 T3	Slv	39019	QH300T3/CL	120	12	Infrared (100)*		5000	C-8	8 ¹⁵ / ₃₂	4 ³ / ₁₆	2400	
	375 T3	Slv	21337	QH375T3/CL	115/5	12	Infrared (100)*		5000	C-8	8 ¹³ / ₁₆	5 ¹ / ₁₆	2400	
	375 T3	R7S	38893	QH375T3/CL/7	120	12	Infrared (100)*		5000	C-8	8 ¹¹ / ₁₆	5 ¹ / ₁₆	2400	
500 WATTS														
	500 T3	Slv	21788	QH500T3/CL	120	12	Infrared, Clear (100)*		5000	C-8	8 ¹³ / ₁₆	4 ¹³ / ₁₆	2400	
	500 T3	R7S	21787	QH500T3/CL/7	120	12	Infrared (100)*		5000	C-8	8 ¹¹ / ₁₆	4 ¹³ / ₁₆	2400	
1000 WATTS														
	1000 T3	Slv	22355	QH1000T3/CL	200/0	12	Infrared (100)*		5000	C-8	13 ¹³ / ₁₆	10	2400	
			22357	QH1000T3/CL	230/0	12	Infrared (100)*		5000	C-8	13 ¹³ / ₁₆	10	2400	
			22358	QH1000T3/CL/1	230/0	12	Infrared, Clear, Horizontal (100, 125)*		5000	C-8	11 ⁷ / ₈	10	2400	
			22365	QH1000T3/2CL/HT	230/0	12	Infrared, Clear, High Temp, Constr., Horizontal (125)*		5000	C-8	13 ¹³ / ₁₆	10	2400	
1200-1600 WATTS														
	1200 T3	Slv	22531	QH1200T3/CL	144	12	Infrared, Clear, Horizontal (100, 123, 125)*		5000	C-8	8 ¹³ / ₁₆	6 ¹ / ₈	2450	
			22532	QH1200T3/CL/HT	144	12	Infrared, Clear, High Temp, Constr., Horizontal (125)*		5000	C-8	8 ¹³ / ₁₆	6 ¹ / ₈	2450	
	1600 T3	Slv	22686	QH1600T3/CL	200/0	12	Infrared, Horizontal (100)*		5000	C-8	19 ¹³ / ₁₆	15 ⁷ / ₈	2350	
	1600 T3	R7S	22699	QH1600T3/CL/7	200/0	12	Infrared, Horizontal (100)*		5000	C-8	19 ⁵ / ₈	15 ⁷ / ₈	2350	
			22691	QH1600T3/CL/7	230/0	12	Infrared, Horizontal (100)*		5000	C-8	19 ⁵ / ₈	15 ⁷ / ₈	2400	
	1600 T3	Slv	22688	QH1600T3/CL	230/0	12	Infrared, Clear, Horizontal (100)*		5000	C-8	19 ¹³ / ₁₆	15 ⁷ / ₈	2400	
			22695	QH1600T3/CL	277	12	Infrared, Horizontal (100)*		5000	C-8	19 ¹³ / ₁₆	15 ⁷ / ₈	2400	
2000 WATTS														
	2000 T3	Slv	22789	QH2M/T3/1CL/HT	230/0	12	Infrared, Clear, High Temp, Constr.		5000	C-8	11 ¹⁵ / ₁₆	9 ¹¹ / ₁₆	2450	
			15551	QH2M/T3/1CL/HT/VB	230/0	12	Infrared, Clear, High Temp, Constr., Universal (123, 125)*		500	C-8	11 ¹⁵ / ₁₆	9 ¹¹ / ₁₆	2450	
			18668	QH2MT3/CL/VB	220/0	12	Infrared, Clear, Universal (123)*		5000	C-8	13 ¹³ / ₁₆	11 ¹ / ₁₆	2450	
			22790	QH2M/T3/CL/HT	230/0	12	Infrared, Clear, High Temp, Constr., Horizontal (125)*		5000	C-8	13 ¹³ / ₁₆	10	2450	
	2000 T3	CER	12716	QH2MT3/CL/HT/R	230/0	12	Infrared, Clear, High Temp, Horizontal, Reflector 170° (125)*		5000	C-8	13 ²⁹ / ₃₂	11 ¹ / ₁₆	2450	
2500 WATTS														
	2500 T3	Slv	22838	QH2500T3/CL	460/0	12	Infrared, Clear, Horizontal (100)*		5000	C-8	28 ¹³ / ₁₆	24 ⁷ / ₈	2400	
	2500 T3	R7S	22837	QH2500T3/CL/7	460	12	Infrared, Clear, Horizontal (100)*		5000	C-8	28 ⁵ / ₈	24 ⁷ / ₈	2400	
3650-5000 WATTS														
	3650 T3	Slv	10872	QH3650T3/CL/5	480	6	Infrared, Horizontal (100)*		5000	C-8	41 ⁵ / ₈	38	2500	
	3800 T3	Slv	22875	QH3800T3/CL	550/0	6	Infrared, Horizontal (100)*		5000	C-8	41 ¹³ / ₁₆	38	2500	
			22878	QH3800T3/CL/VB	550/0	6	Infrared, Clear, Universal (100, 123)*		5000	C-8	41 ¹³ / ₁₆	38	2500	
	5000 T3	Slv	22900	QH5M/T3/1CL/HT	575/5	12	Infrared, Clear, High Temp, Constr., Horizontal (100, 125)*		5000	C-8	28 ¹³ / ₁₆	25 ¹ / ₄	2500	



GENERAL INFORMATION

HALOGEN LAMP OPERATING PRECAUTIONS

The lamps listed in this catalog are filled to high internal gas pressures to maximize lamp efficacy (lumens per watt). Some general cautions are given below.

HIGH OPERATING TEMPERATURES

Since operating temperatures are critical to the effective self-cleaning properties of halogen lamps, filament tube wall temperatures should not go below 482°F (250°C). Hot spots on the bulb wall itself can go as high as 1230°F (700°C) in normal operation.

Substantial heat is generated in all halogen lamps, so equipment design should make allowance for the dissipation of excessive heat. Certain lamps and extremely confined fixtures may require additional ventilation or heat sinking to ensure proper operation of the halogen cycle and to prevent damage to the fixture. It is a good practice to test the lamp in the operating environment early in the design cycle to ensure adequate performance. Precautions must be taken in the selection of materials for lampholders, reflectors and lamp housings because the 1230°F (700°C) bulb wall temperature is greater than the kindling temperature of many materials. Lamp base temperatures should not exceed 662°F (350°C) because, above that point, lead wires may deteriorate and the basing cement loosen, causing premature lamp failure.

DISTRIBUTION OF SPECTRAL RADIATION

Halogen lamps offer large amounts of visible and infrared energy from a small light source, with about 90% of the energy in the infrared. Some halogen lamps can be used for special applications where small amounts of ultraviolet energy are required. The slight ultraviolet radiation that comes from unprotected sources could cause skin and eye irritation following extended direct exposure. Passing the light through ordinary glass or plastic provides adequate protection. The lenses of the PAR, TAL or Cover Glass Precise™ lamps provide this protection.

QUARTZ HEAT LAMPS

GE standard quartz heat products are primarily pressurized halogen lamps. Many standard tungsten coil filaments have been converted to a deflection coil winding design that eliminates the need for filament supports through an integral coil/support construction. These changes will improve lamp life as well as keep the bulb wall cleaner during operation and throughout the life of the lamp.

In general, halogen lamps are more efficient than ordinary incandescent lamps. HIR™ lamps are the most efficient halogen lamps we offer. For each application, check life, lumens, wattage, beam spread and lamp dimensions to determine proper bulb selection.

GE has added a reflectorized heat lamp with a patented design that directs the infrared to a surface rather than in 360° angle.

HALOGEN CAUTION NOTICE – GENERAL

Halogen lamps are constructed of a glass bulb with a pressurized internal filament tube that operates at high temperatures and could unexpectedly shatter. Should the outer bulb break, particles of extremely hot glass could be discharged into the fixture enclosure and/or surrounding environment, thereby creating a risk of personal injury or fire.



OPERATING NOTES

- Turn power off and let lamp cool before removal to avoid potential burn and electrical shock during lamp replacement
- Do not use lamp if outer glass is scratched or broken because it may break during installation or later during operation
- Do not use lamp in close proximity to combustible materials or those adversely affected by drying or fading action because of heat radiation in the lamp beam
- Dispose of removed lamp with care such as placing in used lamp carton or other closed container

COMPACT PAR LAMPS (PAR20/30)

- Use outdoors in enclosed fixtures or where protected from exposure to water

QUARTZLINE™ PAR (250W)

- Avoid use where subjected to exposure to moisture which may cause lamp to break or shatter
- Do not operated lamp over 110% rated voltage. Overvoltage operation increases pressure and tendency to break.
- Use this lamp only in fixtures designed for Q250PAR38 lamps

HALOGEN A-LINE (TB/H)

Caution: Cracked or broken bulbs that still light should be replaced immediately. The inner tube of the GE Halogen lamp is pressurized, operates at high temperature and could unexpectedly shatter with the possibility of property damage or personal injury. Avoid use in unstable table lamps. Dispose of with care. To avoid burns, electricity should be switched off and the lamp allowed to cool for several minutes before removing from socket. Use outdoors only in enclosed fixtures or where protected from exposure to water.

OPERATING NOTES – LOW VOLTAGE LAMPS

Low voltage tungsten-halogen lamps are sensitive to voltage variations. Even a small change in voltage can have a considerable impact on lamp life. Designers should match fixture transformer ratings to actual line voltages to ensure that the lamps operate at as close to 12 volts as possible.

Rapid cycling can also shorten lamp life, and designers should take advice from their GE Lighting representative before using these lamps in flashing or blinking applications.

The lamps may be dimmed by reducing voltage. However, this may cause the bulbs to blacken. If this occurs the lamp should be run at full voltage for fifteen minutes, thereby clearing the problem. Note that the nature of low voltage lighting systems requires the use of fluorescent-type dimmers. Lamp can be operated on AC or DC currents.

FOOTNOTES

Footnote

- In "base up" use, heat eventually may deteriorate paper-lined or plastic sockets.
- Lamp is made of heat resistant glass (HRG).
- Lamp base is a brass base (BB).
- This lamp produces base temperatures which may deteriorate paper-lined or plastic sockets. Use only in fixtures approved for this type and wattage bulb.
- Lamp base is a nickel plated brass base (NPBB).
- Avoid use at short distances on materials that are inflammable or susceptible to heat damage.
- Use only in fixtures rated for Cool Beam lamp operation.
- Do not use lamp in application where it may be exposed to direct water splash. If lamp is used outdoors, it must be protected by an enclosed fixture or an overhang. Failure to properly protect the lamp can result in premature failure of the lamp.
- Will operate in any burning position, but fixed-socket usage other than base up or continuous burning in any position in ambient temperatures above 150°F, may result in some loss of protective coating.
- If lamp is cracked or broken, replace immediately. The lamp may continue to light, but the inner bulb is pressurized and could unexpectedly shatter. Dispose of with care.
- Under moist conditions, metal parts of lamp and lampholder may become a shock hazard. Therefore, disconnect from circuit before touching.
- Do not operate lamp over 110% rated voltage. Over voltage operation increases pressure and tendency to break.
- Use this lamp only in fixtures designed for Q250PAR38 lamps.
- For use only where seal temperature does not exceed 650°F. For satisfactory lamp operation a minimum bulb wall temperature of 500°F is required.
- Life dependent on service conditions.
- For a more uniform lighting pattern in display applications calling for ENL, use Precise Lamp (Q50MR16/NFL30 (EXX).
- Although made of heat-resistant glass, the bulb and lens should be protected from moisture or breakage may result. The lens or bulb may break during usage under certain other conditions beyond the control of the manufacturer. Therefore screening is recommended.
- The bulb, although made of heat-resistant glass, may break if moisture falls on it. Lamp not recommended for use in enclosed close-fitting housings.
- Flexible leads not included in maximum overall length.

Footnote

- Continuous operation of the lamp at full amperage for extended periods (longer than 100 hours), or high duty cycle at high temperature may cause coating to delaminate (peel) near the center of the lamp lens.
- Nickel plated brass base (NPBB).
- Initial Avg. Max. Candlepower (Average over a 5 cone for SP and NSP and over a 10 cone for FL and NFL).
- 36mm stranded leads with lug terminals.
- Can be operated in any position, even vertically; however, when burned other than horizontally, the end marked "This End Up" on the sleeve base must be higher than other end of lamp.
- Generally limited to intermittent burning in special equipment.
- D.C. Bayonet (Ba15d) base with ring collar added. Light Center Length measured from plane of the three bosses on ring collar.
- For use only with heat-resistant connector and with lamp supported by bulb rim.
- For use only in equipment designed for lamps of this type and wattage, having ventilation adequate to maintain bulb and base temperatures within safe limits.
- Lamp provides maximum filament straightness under severe operating conditions.
- MOL dimension includes only length of quartz.
- Filament: diameter, 3.6mm; length, 5.5mm (10%).
- Filament: diameter, 1.5mm; length, 4.5mm (10%).
- Filament: diameter, 1.5mm; length, 10mm (10%).
- Filament: diameter, 3mm; length, 10mm (10%).
- Filament dimension: diameter, 1.9mm; length, 6.4mm (10%).
- Filament offset 0.0359 from center axis of lamp.
- Approx. 1" (25mm) ribbon leads extending along axis of the lamp.
- Initial average beam candlepower within cone is 15,500.
- Approx. 1" ribbon leads extending normal to lamp axis in same plane as seals.
- Recessed Single Contact base with metal ferrule. Designed for use only in special equipment, not for general use. The non-insulated ferrules are exposed and may be energized.



METAL HALIDE LAMPS

Arcstream™ 3-14
ChromaFit™ Multi-Vapor® 3-13
ConstantColor® CMH™ 3-9
High Output Multi-Vapor® 3-12
I-Line Multi-Vapor® 3-14
Multi-Vapor® 3-10
Protected High Output Multi-Vapor® 3-13
PulseArc™ Multi-Vapor® 3-9
Saf-T-Gard® Multi-Vapor® 3-14

HIGH PRESSURE SODIUM LAMPS

Deluxe Lucalox® 3-17
Ecolux® NC Non-Cycling 3-17
E-Z Lux® 3-17
Lucalox® 3-15

LOW PRESSURE SODIUM LAMPS

SOX Low Pressure Sodium 3-17

MERCURY LAMPS

E-Z Merc® Self-ballasted 3-19
Saf-T-Gard® Mercury 3-19
Standard Mercury 3-18

EXPORT LAMPS

Export Lamps 3-20



BULB IDENTIFICATION

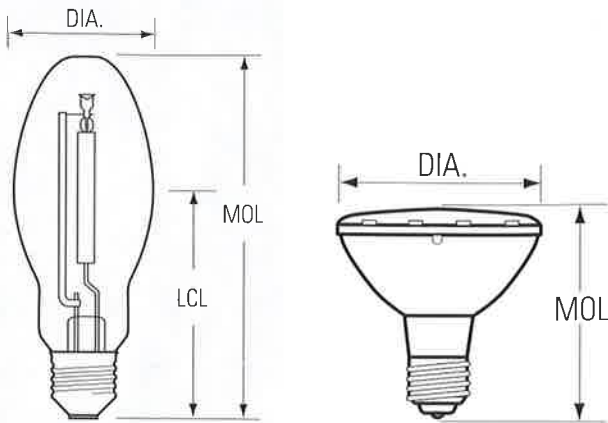

DIA: Diameter of bulb at widest point.
 MOL: Maximum Overall Length including base or pins.
 LCL: Distance between the center of the arc tube and the Light Center Length reference plane.
 Note: Lamp drawings are not drawn to scale.
 Be sure to check size and dimension information when identifying each lamp.

To convert inches to millimeters, multiply the dimension (in inches) by 25.4 (i.e. 1.5" x 25.4 = 38.1 mm).

LAMP LOCATOR

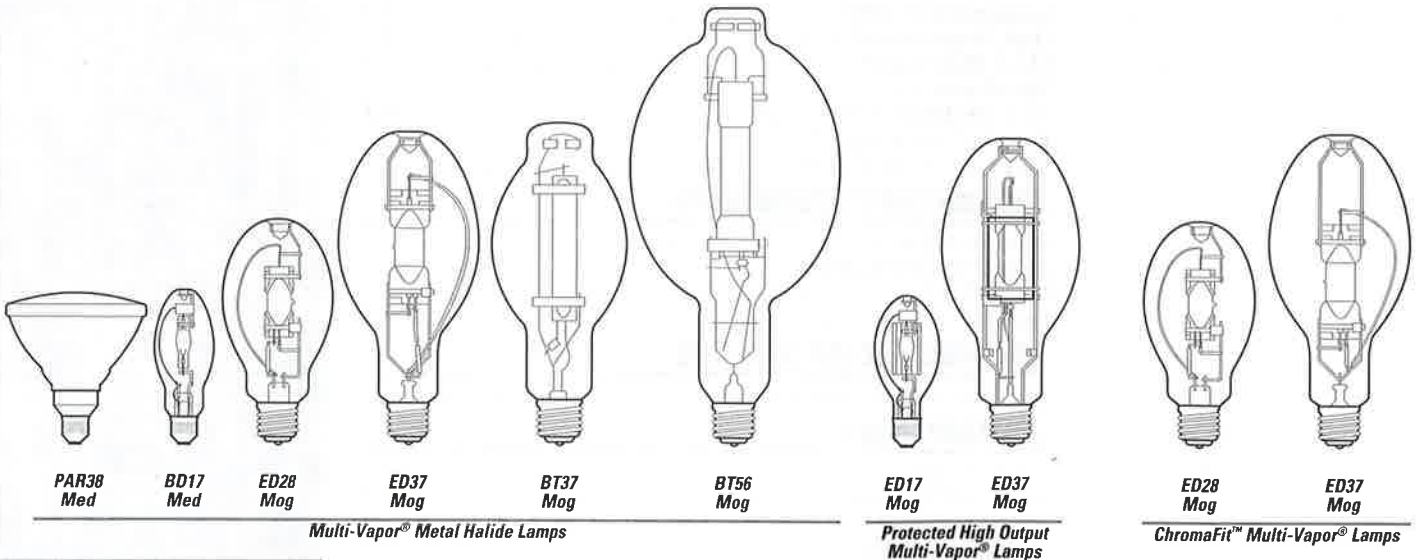
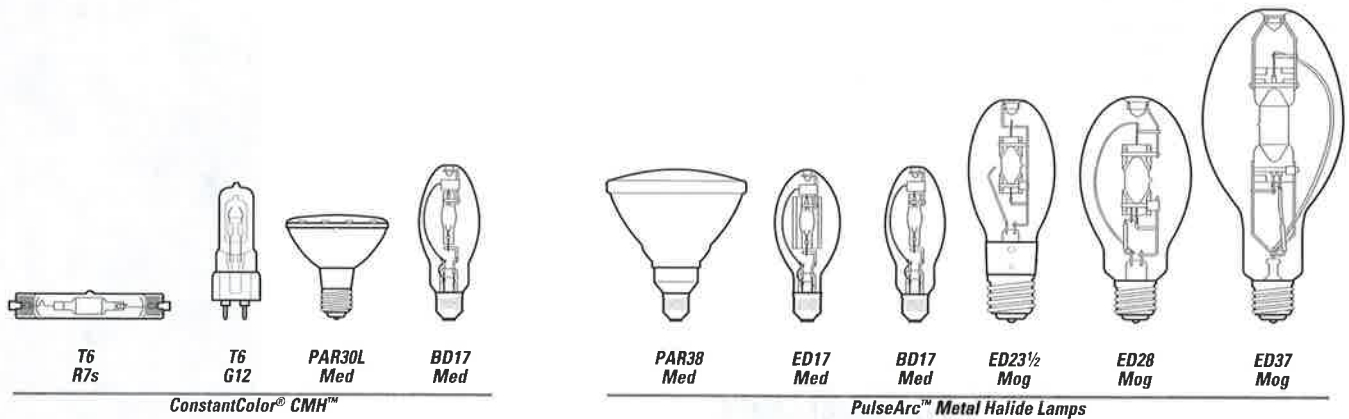

High Intensity Discharge Lamps

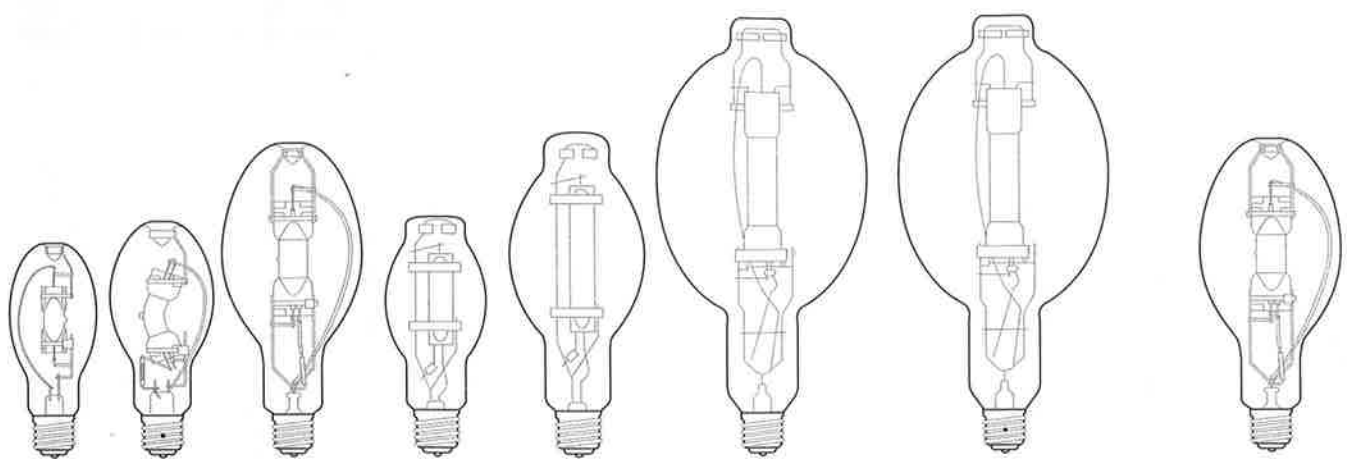

ED23 1/2
Mog

ED28
PosMog

ED37
Mog

BT28
Mog

BT37
Mog

BT56
Mog

BT56
Pos Mog

ED37
Mog

High Output Multi-Vapor® Metal Halide Lamps

Saf-T-Gard® Self-Extinguishing
Multi-Vapor Lamps

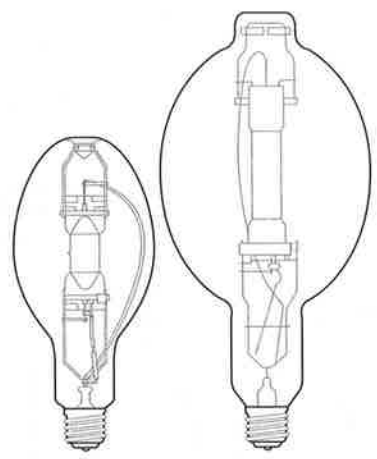

ED37
Mog

BT56
Mog

I-Line Multi-Vapor® Lamps

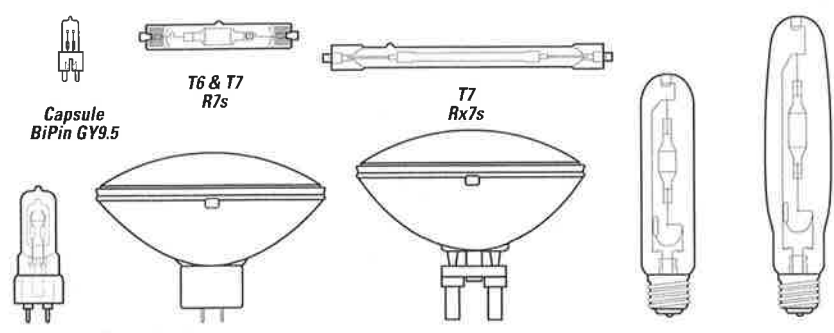

Capsule
BiPin GY9.5

T6 & T7
R7s

T7
Rx7s

T6
BiPin G12

PAR64
Ex Mog End Pr

PAR64
G38

T15
Mog

ED18
Mog

Arcstream™ Metal Halide Lamps

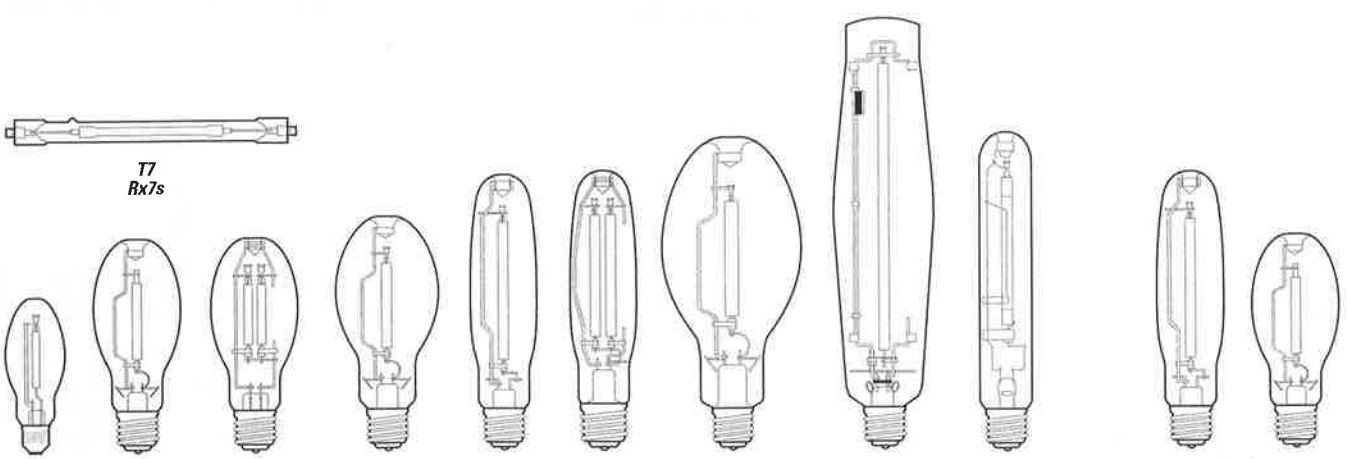

T7
Rx7s

B17
Med

ED23 1/2
Mog

ED23 1/2
Mog (SBY/LL)

ED28
Mog

ED18
Mog

ED18
Mog (SBY/LL)

ED37
Mog

E25
Mog

T15
Mog

ED18
Mog

ED23.5
Mog

Lucalox® High Pressure Sodium Lamps

Ecolux® NC Non-Cycling High
Pressure Sodium Lamps

High Intensity Discharge Lamps

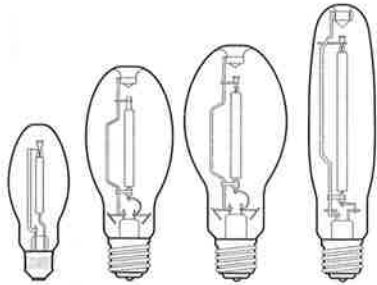

B17 Med **ED23 1/2 Mog** **ED28 Mog** **ED18 Mog**

Deluxe Lucalox® High Pressure Sodium Lamps

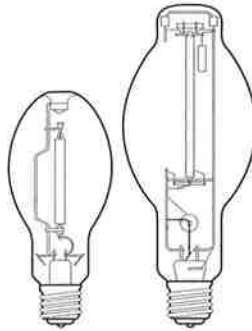

ED28 Mog **BT37 Mog**

E-Z Lux® High Pressure Sodium Lamps

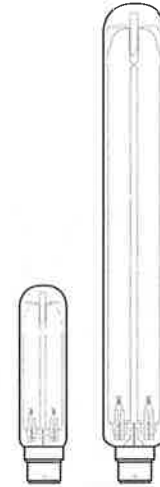

T16 B22d **T21 B22d**

SOX Low Pressure Sodium Lamps

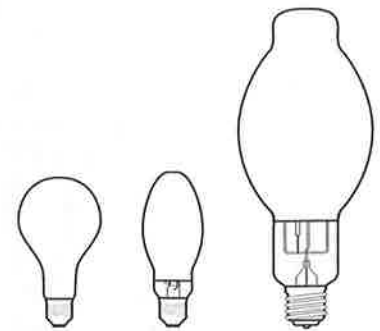

A23 1/2 Med **B17 Med** **BT37 Mog**

Mercury Lamps

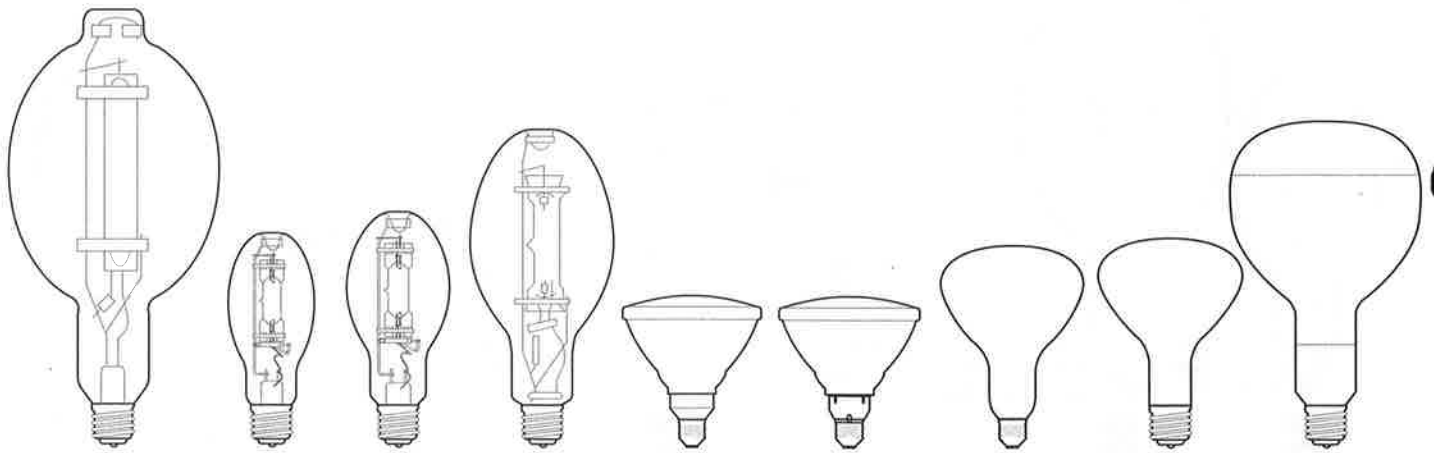

BT56 Mog **ED23 1/2 Mog** **ED28 Mog** **ED37 Mog** **PAR 38 Med Skrt** **PAR 38 Admed Skrt** **R40 Med** **R40 Mog** **R52 Mog**

Mercury Lamps (continued)

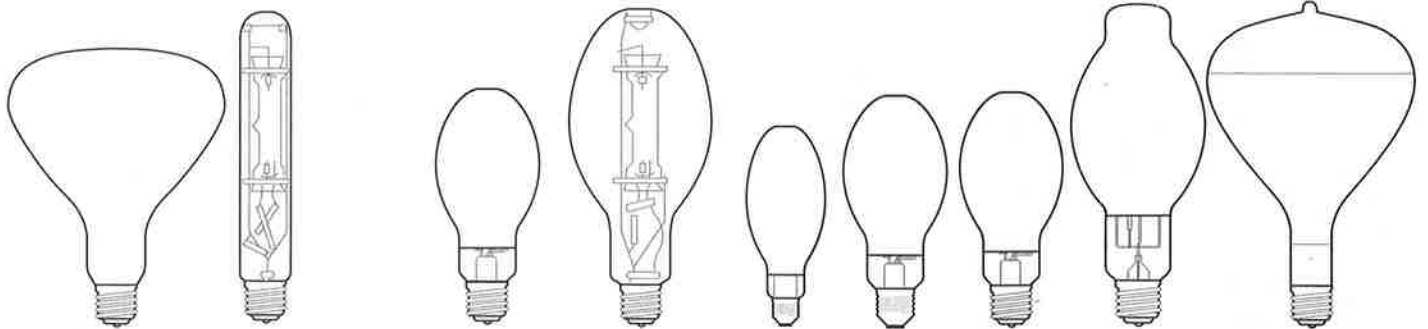

R60 Mog **T16 Mog** **ED28 Mog** **ED37 Mog** **ED24 Med** **ED28 Med** **ED28 Mog** **BT37 Mog** **R57 Mog**

Mercury Lamps (continued)

Saf-T-Gard® Mercury Lamps

E-Z Merc® Self-Ballasted Lamps



BASE IDENTIFICATION



Med Screw
E26



Export
E27



Mog Screw
E39



Export
E40

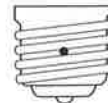

Position-
Oriented Mogul

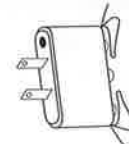

Ext. Mog End Pr
GX16d

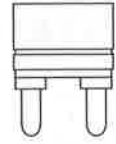

Mogul BiPost
G38

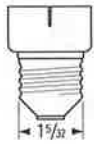

Admedium Skirted

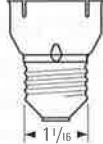

Med Skirt
E26/50x39

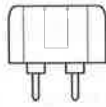

BiPin
G12



PG12
(Export Only)



Recessed
Single Contact
R7s



2-Lug Sleeve
B22d

INTRODUCTION

GE HID lamps provide the following benefits:

High Efficacy/Low Operating Cost.

HID is generally the most efficient light source. Better efficiency almost always means lower operating cost.

Long Life.

Most HID lamps have life ratings that are better than incandescent lamps and similar to fluorescent lamps.

Compact Size.

An HID lamp produces high light output from a relatively compact source. Like incandescent, it is a "point" light source, which allows for good optical control.

The chart below shows how HID lamps compare to incandescent, halogen, and fluorescent in terms of efficiency and rated average life. Efficiency is measured in lumens per watt (LPW). Rated average life for most lamp types is the number of burning hours when 50% of the tested samples have failed and 50% are still operational. For both HID and fluorescent, lamp life depends on the number of hours per start.

The combination of high efficiency and long life makes HID an ideal light source for many commercial and industrial applications.

SUGGESTED COLOR APPLICATIONS FOR HID LAMPS

CMH™: Stores, people places, display, accent.

MVR: Stores, public spaces, industrial, gymnasiums, floodlighting signs and buildings, parking areas, sports.

MVR/C: Same as MVR – warmer color – diffuse coating reduces glare.

MVR/SP30: Same as MVR – warmer than MVR or MVR/C – matches SP30 fluorescent.

MXR: Warm color (3200K) – good match for halogen.

LU: Street lighting, parking areas, industrial, floodlighting, security, CCTV.

LU/DX: Floodlighting, parking areas, indoor/outdoor pedestrian malls, industrial, security, roadway.

Deluxe (DX) Mercury: Stores, public spaces – Metal Halide lamps however, are preferred.

Clear Mercury: Landscape lighting, specialized floodlighting such as green copper roofs.

Typical Lamp Characteristics

Lamp Type	Typical LPW	Rated Avg. Life (in hours)
Incandescent	5 - 22	750 - 2000
Halogen	12 - 36	2000 - 6000
Compact Fluorescent	27 - 80	9000 - 20,000
Fluorescent	75 - 100	12,000 - 24,000 +
Mercury	50 - 60	12,000 - 24,000 +
ConstantColor® CMH™	80 - 90	6,000 - 10,000
Multi-Vapor® Metal Halide	80 - 115	10,000 - 20,000
Lucalox® High Pressure Sodium	90 - 140	10,000 - 40,000

PRODUCT INFORMATION

GE CONSTANTCOLOR® CMH™ CERAMIC METAL HALIDE LAMPS (pg 3-9)

- Color uniformity lamp-to-lamp and over lamp life
- Excellent color rendering (85+CRI)
- Delivers more light than standard metal halide (10%–20% more than standard metal halide)
- Lamp operates at high efficacy — up to 95 lumens per watt
- Universal burn — may be operated in any position
- Easy retrofit since lamp operates on standard metal halide ballasts
- Perfect for retail and commercial display lighting, accent and floodlighting, lobby and foyer lighting. Ideal for "people places."



PRODUCT INFORMATION (Continued)

GE PULSEARC™ MEDIUM BASED METAL HALIDE LAMPS (/MED MODELS) (pg 3-9 and 3-10)

- Low wattage metal halide lamps (formerly Halarc®) are now part of the PulseArc™ family
- Compact source
- Sparkling white light (3000-4000K) and very good color rendition (70-75CRI)
- High efficacy – more than 3 times the lumens per watt of incandescent
- Long life – up to 15 times longer than incandescent systems and up to 7 times longer than most PAR and R systems, saving maintenance and labor costs
- Superior optical control
- Uses: Display lighting, downlighting, floodlighting, corridors, lobbies, walkways; retail, office, commercial

GE PULSEARC™ MULTI-VAPOR® METAL HALIDE LAMPS (/PA MODELS) (pg 3-10)

- Designed for operation only on approved ballasts with metal halide pulse ignitors
- More light – 400W lamps provide highest initial and highest maintained lumens versus other standard universal or vertical base-up lamp options
- 50% longer life – 400W lamps provide 30,000 hours life when burned on 120 hour on/1 hour off cycle (approximately continuous)
- Faster hot restrike – less than 4 minutes versus 10-15 minutes for typical metal halide lamps

GE MULTI-VAPOR® METAL HALIDE LAMPS (pg 3-10 and 3-11)

- Sparkling white light (3000-4000K) and very good color rendition (65-75CRI)
- Warm, rich 3000K color of SP30 blends well with incandescent, halogen and triphosphor fluorescent lamps for interior retail applications
- High efficacy – more efficient than incandescent, mercury and most fluorescent sources
- Long life – 10,000-20,000 hours for most types
- Full line, 150-1000 watts, to meet most application needs
- Uses: Downlighting, floodlighting, corridors, lobbies, walkways; retail, commercial, industrial

GE HIGH OUTPUT MULTI-VAPOR® LAMPS (pg 3-12 and 3-13)

- More light – optimized for higher light output in horizontal, vertical base-up and base-down burn applications
 - Horizontal burn lamps provide up to 25% more light than standard universal burn equivalents
 - Vertical burn lamps provide up to 11% more light than standard universal burn equivalents
 - 400W/XHO (formerly /XL) vertical burn lamps provide up to 17% more light than standard universal burn equivalents; the highest lumen lamps available for operation on standard M59 ballasts
- Longer life – horizontal burn lamps last up to 67% longer than universal burn lamp equivalents, significantly reducing replacement lamp and maintenance costs
- Brighter longer - introducing GE Staybright™ (/STB) with 30% higher mean lumens
- Uses: any application where fixed-orientation lamps can be used. Gas stations, sports lighting, billboards, retail, office, roadway, parking garages, floodlights, sign lighting.

GE PROTECTED HIGH OUTPUT MULTI-VAPOR® LAMPS (/O) (pg 3-13)

- Protective quartz jacket surrounds the arc tube
- The /O suffix in the Lamp Description indicates lamps are suitable for open fixture applications

GE CHROMAFIT™ MULTI-VAPOR® LAMPS (/R) (pg 3-13)

- Convert high pressure sodium sockets to crisp white metal halide light
- Operate on standard HPS ballasts and auxiliary equipment
- Uses: Area lighting, industrial and “people places”

GE I-LINE MULTI-VAPOR® LAMPS (pg 3-14)

- Convert mercury sockets to crisp, white metal halide light
- More light, better color, energy cost savings for mercury users
- 40%-100% more light than existing mercury lamps
- Operate on standard CW and CWA mercury ballasts and auxiliary equipment

GE SAF-T-GARD® MULTI-VAPOR LAMPS (MVT) (pg 3-14)

- Special self-extinguishing feature prevents exposure to harmful UV in case outer bulb is punctured or broken; lamp turns off within 15 minutes
- Certified to meet Federal Standard 21CFR1040.30
- Saf-T-Gard® I-line lamps convert mercury sockets to crisp, white metal halide light
- Saf-T-Gard® I-line lamps operate on standard mercury ballasts and auxiliary equipment
- Uses: Industrial, commercial, gymnasiums, sports complexes, especially where open fixtures are used and risk of outer bulb breakage is possible

GE ARCSTREAM™ METAL HALIDE LAMPS (pg 3-14 and 3-15)

- Compact size, white light, excellent color
- Precise optical control delivers a concentrated beam of light right where it's needed
- Variety of color temperatures (3,000K - 6,000K)
- PAR64: ideal for long-range projection and sports lighting applications
- Uses: Ideal for retail and commercial display lighting, floodlighting, accent/highlighting

GE LUCALOX® HIGH PRESSURE SODIUM LAMPS (pg 3-15 and 3-16)

- Very high efficacy/low operating cost
- Superior lumen maintenance – over 90% @ 50% of life
- Very long life – 24,000+ hours
- Universal burn – can be operated in any position without affecting performance
- Warm color
- For open or enclosed fixtures
- Uses: Industrial, roadway, security, floodlighting



PRODUCT INFORMATION (Continued)

GE STANDBY LONGLIFE LUCALOX® LAMPS (/SBY) (pg 3-15 and 3-16)

- Extra arc tube provides light instantly after momentary power interruption, and will increase to 80% light output in 1-2 minutes
- Dual arc tubes provide 40,000 hour rated life
- Operates on standard HPS ballasts and auxiliary equipment
- Uses: Industrial, roadway, security, and hard-to-reach sockets

GE ECOLUX® NC "NON-CYCLING" HIGH PRESSURE SODIUM LAMPS (/ECO/NC) (pg 3-17)

- Low mercury. Passes TCLP, which can lower disposal costs.
- Non-cycling feature makes locating and replacing end-of-life lamps quick and easy
- Lead-free base
- High efficacy/low operating cost
- 6%-11% higher initial lumens than standard HPS in 100W and 400W versions
- Long life - 24,000 hours
- Open or enclosed fixtures
- Uses: Industrial, roadway, security

GE DELUXE LUCALOX® HIGH PRESSURE SODIUM LAMPS (pg 3-17)

- High efficacy, lumen maintenance and long life of standard Lucalox® HPS
- High color rendering (65-70CRI), much better than standard HPS
- Blends well with incandescent and standard HPS sources
- Operates on standard HPS ballasts and auxiliary equipment
- Uses: Storage rooms, industrial facilities, offices, gymnasiums, malls, parks, building floodlighting

GE DOUBLE-ENDED LUCALOX® LAMPS (/TD) (pg 3-16)

- Compact tubular design fits compact fixtures for excellent optical control
- High efficacy, lumen maintenance and long life of standard Lucalox® HPS

GE E-Z LUX® HIGH PRESSURE SODIUM LAMPS (pg 3-17)

- Direct replacement for mercury lamps on mercury ballasts
- More efficient, 57-114% more lumens and 10-14% fewer watts than mercury lamps they replace
- Uses: General lighting, roadway
- See operating notes for further information

GE SOX LOW PRESSURE SODIUM LAMPS (pg 3-17 and 3-18)

- Highest luminous efficacy for general, not for color-critical lighting
- Monochromatic, yellow color (589nm)

GE MERCURY LAMPS (pg 3-18 and 3-19)

- Long life and good efficacy
- Phosphor coated Deluxe lamps provide good color rendering (50CRI)
- Uses: Industrial, roadway, landscapes, residential and commercial security, parking lots

GE SAF-T-GARD® MERCURY LAMPS (pg 3-19)

- Special self-extinguishing feature prevents exposure to harmful UV in case outer bulb is punctured or broken; lamp turns off within 15 minutes
- Certified to meet Federal Standard 21 CFR 1040.30
- See operating notes for further information

GE EZ MERC® SELF BALLASTED MERCURY LAMPS (pg 3-19)

- Retrofit incandescent sockets to longer-life mercury lamps without additional mercury ballasts or auxiliary equipment

GE EXPORT BASE LAMPS (pg 3-20)

- Export-only lamps are not intended for use in North America due to potential shock hazard. The lamps are identified by "/27" or "/40" at the end of the lamp description, and comply with electrical characteristics defined by IEC standards.
- Bulb shapes are generally similar to U.S. lamp types. Refer to drawings on pages 3-2 to 3-4.

HID BRAND NAME CROSS-REFERENCE

GE	OSRAM/SYLVANIA	PHILIPS
Arcstream™ MQI	BRITE-LINE™, HQI®	MHN-TD
ChromaFit™ Multi-Vapor®	—	—
ConstantColor® CMH™ Ceramic Metal Halide	—	MasterColor™ CDM
Deluxe Lucalox®	—	Ceramalux™ Comfort
E-Z Lux®	Unalux®	Ceramalux™ Retrolux
E-Z Merc®	—	Self Ballasted Mercury
Ecolux® NC	Lumalux Plus™/ECO™	Ceramalux Alto™
High Output Multi-Vapor®	Super Metalarc®	Metal Halide
Horizontal Multi-Vapor®	Super Metalarc®	—
I-Line Multi-Vapor®	—	—
Lucalox®	Lumalux®	Ceramalux™
Multi-Vapor®	Metalarc®	Metal Halide
Protected High Output Multi-Vapor®	Metalarc® Pro-Tech™	—
PulseArc™	Super Metalarc® Pulse Start	Pulse Start
Saf-T-Gard™ Mercury	Mercury Safeline®	Safety Lifeguard Mercury
Saf-T-Gard™ Multi-Vapor®	Metalarc® Safeline®	Safety Lifeguard Metal Halide
SOX Low Pressure Sodium	SOX Low Pressure Sodium	SOX Low Pressure Sodium
Standby Longlife Lucalox®	Lumalux® Standby	Instant Restrike Ceramalux™
Watt-Miser® Multi-Vapor®	—	—

ATTENTION: This brand-name cross-reference chart is provided only as a quick reference. Other lamp company brand listings may only represent a near equivalent, versus an identical match to GE Lighting brands. Individual lamp manufacturers' performance specifications should be consulted. Lamp performance may be affected by environmental conditions, ballast type and/or other auxiliary equipment.



HEADINGS IN THIS CATALOG SECTION

The following terms and descriptions can help you when checking High Intensity Discharge lamp specifications and when ordering products. Within each product line, lamps are divided into families. Within families, lamps are listed by wattage. In each of these wattage groups, lamps are listed by bulb shape.

Color Rendering Index (CRI or R_a):
An indication of the ability of the lamp to render object colors in a normal, natural way. The higher the number (0-100), the better the color appearance.

Color Temperature Kelvins (K):

A measure of the visual "warmth" or "coolness" of the light from the lamp. The higher the value the whiter or "cooler" the light appears.

Lumens - Mean:

Lamp light output (lumens) at 40% of rated lamp life for Metal Halide lamps and 50% of rated life for Mercury and HPS lamps.

MOL:
Maximum Overall Length in inches.

LCL:
Distance between the center of the filament and the Light Center Length reference plane, in inches.

Rated Avg Life - Hrs:
Lamp burning hours to median life expectancy.

Bulb:

Bulb shape followed by its size (the maximum diameter of the bulb expressed in eighths of an inch).

Product Code:

It is important to use this five-digit code when ordering to ensure that you receive the exact product you require.

Base:

The type of base.

Lamp Description:

The lamp's identification code.

Case Qty:

Number of product units packed in a case.

Fixture Req:

Describes fixture requirements for this lamp (see page 3-21).

Additional Information:

Typical application and/or other important information including footnotes (*).

Lumens - Initial:
Initial light output.

ANSI Ballast Type:

Ballast type used to operate lamp.

Bulb	Base	Product Code	Lamp Description	Case Qty.	Fix. Req.	Additional Information	ANSI Ballast Type	Lumens Initial	Lumens Mean*	Rated Avg. Life Hours	MOL in.	LCL in.	Color Temp. K	CRI
------	------	--------------	------------------	-----------	-----------	------------------------	-------------------	----------------	--------------	-----------------------	---------	---------	---------------	-----

HIGH OUTPUT MULTI-VAPOR® METAL HALIDE LAMPS

400 WATTS

ED37	Mog	49656	MVR400/C/VBU	6	0	Coated, Vertical Base Up ±15° M59		41000	25000	20000	11 ⁵ / ₁₆	7	3700	70
------	-----	-------	--------------	---	---	-----------------------------------	--	-------	-------	-------	---------------------------------	---	------	----

MVR400 / C / VBU

Identifies as Multi-Vapor® lamp.

Identifies the lamp's wattage.

Outer bulb finish.

Burning position (see page 3-21)

WHEN YOU DON'T KNOW THE LAMP DESCRIPTION

1. Identify bulb shape by using illustrations on pages 3-2 to 3-4.
2. Measure bulb diameter using ruler in Appendix section page A-1 to determine width in eighths of an inch.
3. Identify base type using table on page 3-5.
4. Find your lamp in the tabular data containing the bulb shape, size and base, which are all listed by wattage.



Bulb	Base	Product Code	Lamp Description	Case Qty.	Fix. Req.	Additional Information	ANSI Ballast Type	Lumens Initial	Lumens Mean [†]	Rated Avg. Life Hours	MOL in.	LCL in.	Color Temp. K	CRI
CONSTANTCOLOR[®] CMH[™] METAL HALIDE LAMPS														
70 WATTS														
T6	G12	35421	CMH70/T/830/G12	10	E	Clear (31, 33)*	M85 or M98 (Alt)	6200	4750	6000	3 ¹⁵ / ₁₆	2 ³ / ₁₆	3000	85
T6	R7s	34519	CMH70/TD/830/R7S	12	E	Clear, Horizontal ±45° Only (31, 33)*	M85 or M98 (Alt)	6200	4750	10000	4 ⁵ / ₈	2 ¹ / ₄	3000	85
BD17	Med	22119	CMH70/U/830/MED	6	E	Clear	M98	6200	4470	7500	5 ⁷ / ₁₆	3 ³ / ₈	3000	85
		22124	CMH70/C/U/830/MED	6	E	Coated	M98	5890	3800	7500	5 ⁷ / ₁₆	3 ³ / ₈	3000	85
PAR30L	Med	22152	CMH70/U/PAR30L/15	6	O	Beam Spread 15°, 25,000 CBCP	M98	4100	3140	6000	4 ³ / ₄		3000	85
		22159	CMH70/U/PAR30L/40	6	O	Beam Spread 40°, 7,000 CBCP	M98	4100	3140	6000	4 ³ / ₄		3000	85
150 WATTS														
T6	RX7s	36912	CMH150/TD/830/RX7S	12	E	Clear, UV Control, Horizontal ±45° Only (31, 33, 39)*	M81 or M102 (Alt)	13500	10350	7000	5 ³ / ₈	2 ⁵ / ₈	3000	85
T6	G12	36863	CMH150/T/830/G12	10	E	Clear, UV Control (31, 33, 39)*	M81 or M102 (Alt)	13500	10350	6000	4 ⁵ / ₈	2 ¹ / ₄	3000	85
PULSEARC[™] MULTI-VAPOR[®] METAL HALIDE LAMPS														
32 WATTS														
ED17	Med	12651	MXR32/C/VBD/O	6	O	Coated, Vertical Base Down ±15°	M100	2400	1700	10000	5 ⁷ / ₁₆	3 ⁷ / ₁₆	3200	70
		16469	MXR32/C/VBU/O	6	O	Coated, Vertical Base Up ±15°	M100	2400	1700	10000	5 ⁷ / ₁₆	3 ⁷ / ₁₆	3200	70
MXR32 METAL HALIDE BALLAST														
		18778	HAL32/120	6		Ballast for 120v 60Hz service	M100							
50 WATTS														
BD17	Med	10361	MXR50/U/MED	6	E	Clear	M110	3900	2200	5000	5 ⁷ / ₁₆	3 ⁷ / ₁₆	3200	70
		10364	MXR50/C/U/MED	6	E	Coated	M110	3500	1900	5000	5 ⁷ / ₁₆	3 ⁷ / ₁₆	3200	70
		12581	MVR50/U/MED	6	E	Clear	M110	3100	1900	5000	5 ⁷ / ₁₆	3 ⁷ / ₁₆	4000	75
		12583	MVR50/C/U/MED	6	E	Coated	M110	2900	1600	5000	5 ⁷ / ₁₆	3 ⁷ / ₁₆	4000	75
70 WATTS														
ED17	Med	12377	MXR70/U/MED/O	6	O	Clear	M98	5500	3500	12000	5 ⁷ / ₁₆	3 ⁷ / ₁₆	3200	70
		12577	MXR70/C/U/MED/O	6	O	Coated	M98	5300	3300	12000	5 ⁷ / ₁₆	3 ⁷ / ₁₆	3200	70
BD17	Med	22158	MXR70/U/MED	6	E	Clear	M98	5500	3500	12000	5 ⁷ / ₁₆	3 ⁷ / ₁₆	3200	70
		22162	MXR70/C/U/MED	6	E	Coated	M98	5300	3300	12000	5 ⁷ / ₁₆	3 ⁷ / ₁₆	3200	70
		12590	MVR70/U/MED	6	E	Clear	M98	4700	3000	12000	5 ⁷ / ₁₆	3 ⁷ / ₁₆	4000	75
		12594	MVR70/C/U/MED	6	E	Coated	M98	4500	2800	12000	5 ⁷ / ₁₆	3 ⁷ / ₁₆	4000	75
PAR38	Med	12741	MXR70/U/PAR/SP	12	O	Clear, Spot, Beam Spread 12°, 50,000 CBCP	M98	4000	2740	7500	5 ⁷ / ₁₆		3000	70
		12745	MXR70/U/PAR/FL	12	O	Clear, Flood, Beam Spread 40°, 6,500 CBCP	M98	4000	2740	7500	5 ⁷ / ₁₆		3000	70
		12746	MXR70/U/PAR/WFL	12	O	Clear, Wide Flood, Beam Spread 60°, 3,200 CBCP	M98	4000	2740	7500	5 ⁷ / ₁₆		3000	70

[†] In actual applications, mean lumens will be higher for Metal Halide lamps operated on CW or CWA ballasts

To save energy costs, find the bulbs with the light output you need, then choose the one with the lowest watts.

() * All footnote references found at the end of this section. ➔ Reduced Wattage ⚡ High Color Rendering. To convert inches to millimeters, multiply by 25.4.

High Intensity Discharge Lamps



Bulb	Base	Product Code	Lamp Description	Case Qty.	Fix. Req.	Additional Information	ANSI Ballast Type	Lumens		Rated Avg. Life Hours	MOL in.	LCL in.	Color	
								Initial	Mean [†]				K	CRI
PULSEARC™ MULTI-VAPOR® METAL HALIDE LAMPS (Continued)														
100 WATTS														
ED17	Med	12381	MXR100/U/MED/O	6	O	Clear	M90	9000	6200	15000	5 ⁷ / ₁₆	3 ⁷ / ₁₆	3200	70
		12579	MXR100/C/U/MED/O	6	O	Coated	M90	8500	5900	15000	5 ⁷ / ₁₆	3 ⁷ / ₁₆	3200	70
BD17	Med	18680	MXR100/U/MED	6	E	Clear	M90	9000	6200	15000	5 ⁷ / ₁₆	3 ⁷ / ₁₆	3200	70
		18679	MXR100/C/U/MED	6	E	Coated	M90	8500	5900	15000	5 ⁷ / ₁₆	3 ⁷ / ₁₆	3200	70
		12652	MVR100/U/MED	6	E	Clear	M90	8100	5800	15000	5 ⁷ / ₁₆	3 ⁷ / ₁₆	4000	75
		12653	MVR100/C/U/MED	6	E	Coated	M90	7600	4900	15000	5 ⁷ / ₁₆	3 ⁷ / ₁₆	4000	75
PAR38	Med	12747	MXR100/U/PAR/SP	12	O	Clear, Spot, Beam Spread 12°, 54,000 CBCP	M90	5500	3400	7500	5 ⁷ / ₁₆		3000	70
		12748	MXR100/U/PAR/FL	12	O	Clear, Flood, Beam Spread 40°, 10,000 CBCP	M90	5500	3400	7500	5 ⁷ / ₁₆		3000	70
		12749	MXR100/U/PAR/WFL	12	O	Clear, Wide Flood, Beam Spread 65°, 4,500 CBCP	M90	5500	3400	7500	5 ⁷ / ₁₆		3000	70
150 WATTS														
BD17	Med	22935	MXR150/U/MED	6	E	Clear	M102	12500	8600	15000	5 ⁷ / ₁₆	3 ⁷ / ₁₆	3200	70
		22936	MXR150/C/U/MED	6	E	Coated	M102	12000	8300	15000	5 ⁷ / ₁₆	3 ⁷ / ₁₆	3200	70
		12598	MVR150/U/MED	6	E	Clear	M102	11700	8100	15000	5 ⁷ / ₁₆	3 ⁷ / ₁₆	4000	75
		12604	MVR150/C/U/MED	6	E	Coated	M102	11200	7700	15000	5 ⁷ / ₁₆	3 ⁷ / ₁₆	4000	75
175 WATTS														
ED23 ¹ / ₂	Mog	22342	MXR175/VBU/PA	6	E	Clear, Vertical Base Up ±15° (34)*		17200	13400	15000	7 ¹ / ₂	5	3200	65
		11185	MXR175/C/VBU/PA	6	E	Coated, Vertical Base Up ±15° (34)*		16250	12500	15000	7 ¹ / ₂	5	3200	65
		12622	MVR175/VBU/PA	6	E	Clear, Vertical Base Up ±15° (34)*		17700	13800	15000	7 ¹ / ₂	5	4000	75
		12633	MVR175/C/VBU/PA	6	E	Coated, Vertical Base Up ±15° (34)*		17700	12000	15000	7 ¹ / ₂	5	4000	75
BD17	Med	12636	MVR175/VBU/MED/PA	6	E	Clear, Vertical Base Up ±15° (34)*		17700	13800	15000	5 ³ / ₄	3 ⁷ / ₁₆	4000	75
		12637	MVR175/C/VBU/MED/PA	6	E	Coated, Vertical Base Up ±15° (34)*		16400	12000	15000	5 ³ / ₄	3 ⁷ / ₁₆	4000	75
250 WATTS														
ED28	Mog	26317	MVR250/VBU/PA	12	E	Clear, Vertical Base Up ±15° (30)*	(35)*	23000	16100	15000	8 ¹ / ₄	5	4200	65
		26319	MVR250/C/VBU/PA	12	E	Coated, Vertical Base Up ±15° (30)*	(35)*	21500	15100	15000	8 ¹ / ₄	5	3900	65
								14700	20000					
320 WATTS														
ED28	Mog	27501	MVR320/VBU/PA	12	E	Clear, Vertical Base Up ±15°	M132	31000	18000	15000	8 ¹ / ₄	5	4000	65
400 WATTS														
ED37	Mog	12642	MVR400/VBU/PA	6	O	Clear, Vertical Base Up ±15° (30)*	(36)*	44000	33900	20000	11 ¹⁵ / ₁₆	7	4000	65
		12644	MVR400/C/VBU/PA	6	O	Coated, Vertical Base Up ±15° (30)*	(36)*	42000	30250	20000	11 ¹⁵ / ₁₆	7	4000	65
								28200	30000					
MULTI-VAPOR® METAL HALIDE LAMPS														
150 WATTS — WATT-MISER® ENERGY-SAVING REPLACEMENT FOR 175W METAL HALIDE														
ED28	Mog	13481	➔ MVR150/U/WM	12	E	Clear, Watt-Miser®	M57	13500 V 11500 H	8500 V 7200 H	10000 V 7500 H	8 ¹ / ₄	5	4000	65
		13490	➔ MVR150/C/U/WM	12	E	Coated, Watt-Miser®	M57	12800 V 10900 H	8000 V 6900 H	10000 V 7500 H	8 ¹ / ₄	5	3700	70

[†] In actual applications, mean lumens will be higher for Metal Halide lamps operated on CW or CWA ballasts

To save energy costs, find the bulbs with the light output you need, then choose the one with the lowest watts.

() * All footnote references found at the end of this section. ➔ Reduced Wattage ⚡ High Color Rendering. To convert inches to millimeters, multiply by 25.4.



Bulb	Base	Product Code	Lamp Description	Case Qty.	Fix. Req.	Additional Information	ANSI Ballast Type	Lumens Initial	Lumens Mean†	Rated Avg. Life Hours	MOL in.	LCL in.	Color Temp. K	CRI
MULTI-VAPOR® METAL HALIDE LAMPS (Continued)														
175 WATTS														
BD17	Med	18902	MVR175/U/MED	6	E	Clear	M57	13600 V 11700 H	8600 V 7400 H	10000 V 6000 H	5 ³ / ₄	3 ⁷ / ₁₆	4000	65
		26432	MVR175/U/MED/CP	4	E	Clear, Consumer Pack	M57	13600 V 11700 H	8600 V 7400 H	10000 V 6000 H	5 ³ / ₄	3 ⁷ / ₁₆	4000	65
		19976	MVR175/C/U/MED	6	E	Coated	M57	12900 V 11900 H	8200 V 7900 H	10000 V 6000 H	5 ³ / ₄	3 ⁷ / ₁₆	3900	65
ED28	Mog	47760	MVR175/U	12	E	Clear	M57	13600 V 11700 H	8600 V 7400 H	10000 V 6000 H	8 ¹ / ₄	5	4000	65
		26433	MVR175/U/CP	4	E	Clear, Consumer Pack	M57	13600 V 11700 H	8600 V 7400 H	10000 V 6000 H	8 ¹ / ₄	5	4000	65
		47761	MVR175/C/U	12	E	Coated	M57	12900 V 11900 H	8200 V 7900 H	10000 V 6000 H	8 ¹ / ₄	5	3900	70
		17634	MVR175/SP30/U	12	E	RE730 Phosphor Coating	M57	12000 V 10300 H	7600 V 6500 H	10000 V 6000 H	8 ¹ / ₄	5	3000	70
PAR38	Med	25218	MVR175/PAR38/FL/1	6	E	Clear, One-piece PAR, Flood, 50° Beam Spread, 6,500 CBCP	M57	12000 V	7600 V	7500 V	5 ⁵ / ₈		3800	65
250 WATTS														
ED28	Mog	42729	MVR250/U	12	E	Clear	M58	20800 V 19100 H	13500 V 12400 H	10000 V 6000 H	8 ¹ / ₄	5	4200	65
		26434	MVR250/U/CP	4	E	Clear, Consumer Pack	M58	20800 V 19100 H	13500 V 12400 H	10000 V 6000 H	8 ¹ / ₄	5	4200	65
		42731	MVR250/C/U	12	E	Coated	M58	19800 V 18200 H	12600 V 11600 H	10000 V 6000 H	8 ¹ / ₄	5	3900	70
		17633	MVR250/SP30/U	12	E	RE730 Phosphor Coating	M58	18000 V 16600 H	11500 V 10600 H	10000 V 6000 H	8 ¹ / ₄	5	3000	70
360 WATTS — WATT-MISER® ENERGY-SAVING REPLACEMENT FOR 400W METAL HALIDE														
ED37	Mog	13495	MVR360/VBU/WM	6	0	Clear, Vertical Base Up ±15°, Watt-Miser® (32)*	M59	36000	24000	20000	11 ⁵ / ₁₆	7	4000	65
		13496	MVR360/C/VBU/WM	6	0	Coated, Vertical Base Up ±15°, Watt-Miser® (32)*	M59	35000	21000	20000	11 ⁵ / ₁₆	7	3700	70
400 WATTS														
ED37	Mog	43828	MVR400/U	6	V	Clear	M59	36000 V 33100 H	24000 V 22100 H	20000 V 15000 H	11 ⁵ / ₁₆	7	4000	65
		26435	MVR400/U/CP	4	V	Clear, Consumer Pack	M59	36000 V 33100 H	24000 V 22100 H	20000 V 15000 H	11 ⁵ / ₁₆	7	4000	65
		43829	MVR400/C/U	6	V	Coated	M59	35000 V 32200 H	21000 V 19300 H	20000 V 15000 H	11 ⁵ / ₁₆	7	3700	70
		17632	MVR400/SP30/U	6	V	RE730 Phosphor Coating	M59	31000 V 28500 H	18600 V 17100 H	20000 V 15000 H	11 ⁵ / ₁₆	7	3000	70
ED28	Mog	18904	MVR400/U/ED28	12	E	Clear, Compact Bulb	M59	36000 V 33100 H	24000 V 22100 H	20000 V 15000 H	8 ¹ / ₄	5	4000	65
		19979	MVR400/C/U/ED28	12	E	Coated, Compact Bulb	M59	35000 V 32200 H	21000 V 19300 H	20000 V 15000 H	8 ¹ / ₄	5	3700	70
1000 WATTS														
BT56	Mog	41826	MVR1000/U	6	V	Clear	M47	105000 V 96600 H	66000 V 60700 H	12000 V 9000 H	15 ³ / ₈	9 ¹ / ₂	4000	65
		41827	MVR1000/C/U	6	V	Coated	M47	99800 V 91800 H	59900 V 55100 H	12000 V 9000 H	15 ³ / ₈	9 ¹ / ₂	3400	70
BT37	Mog	18205	MVR1000/U/BT37	6	E	Clear, Compact Bulb	M47	105000 V 96600 H	66000 V 60700 H	12000 V 8000 H	11 ¹ / ₂	7	4000	65

† In actual applications, mean lumens will be higher for Metal Halide lamps operated on CW or CWA ballasts

To save energy costs, find the bulbs with the light output you need, then choose the one with the lowest wattage.

{ } * All footnote references found at the end of this section. ⚡ Reduced Wattage ⦿ High Color Rendering. To convert inches to millimeters, multiply by 25.4.

High Intensity Discharge Lamps



Bulb	Base	Product Code	Lamp Description	Case Qty.	Fix. Req.	Additional Information	ANSI Ballast Type	Lumens Initial	Lumens Mean†	Rated Avg. Life Hours	MOL in.	LCL in.	Temp. K	Color CRI
HIGH OUTPUT MULTI-VAPOR® METAL HALIDE LAMPS														
175 WATTS														
ED23½	Mog	11420	MXR175/VBD	6	E	Clear, Vertical Base Down ±15°, Integral Ignitor (13)*	M57	17200	13400	10000	7¾	5	3200	70
		11417	MXR175/VBU	6	E	Clear, Vertical Base Up ±15°, Integral Ignitor (13)*	M57	17200	13400	10000	7¾	5	3200	70
		11203	MXR175/C/VBU	6	E	Coated, Vertical Base Up ±15°, Integral Ignitor (13)*	M57	16300	12500	10000	7¾	5	3200	70
ED28	Pos Mog	18104	MVR175/HOR	12	E	Clear, Horizontal Burn ±15°, Position-oriented Socket Required	M57	15000	7700	10000	8¼	5	4000	65
		18105	MVR175/C/HOR	12	E	Coated, Horizontal Burn ±15°, Position-oriented Socket Required	M57	14100	7500	10000	8¼	5	3500	70
250 WATTS														
ED28	Pos Mog	18101	MVR250/HOR	12	E	Clear, Horizontal Burn ±15°, Position-oriented Socket Required	M58	21000	10000	15000	8¼	5	4200	65
		18103	MVR250/C/HOR	12	E	Coated, Horizontal Burn ±15°, Position-oriented Socket Required	M58	19700	9400	15000	8¼	5	3600	70
360 WATTS — WATT-MISER® ENERGY-SAVING REPLACEMENT FOR 400W METAL HALIDE														
ED37	Mog	40053	➔ MVR360/VBU/WM/XHO	6	0	Clear, Vertical Base Up ±15°, Watt-Miser®, High Output (32)*	M59	39000	24300	20000	11⅝	7	4200	65
		40055	➔ MVR360/C/VBU/WM/XHO	6	0	Coated, Vertical Base Up ±15°, Watt-Miser®, High Output (32)*	M59	37500	22500	20000	11⅝	7	4000	70
400 WATTS														
ED37	Mog	26865	MVR400/VBU/STB	6	E	Clear, Vertical Base Up ±15° Staybright™	M59	41000	31200	20000	11⅝	7	4000	65
		26866	MVR400/C/VBU/STB	6	E	Coated, Vertical Base Up ±15° Staybright™	M59	41000	27700	20000	11⅝	7	3700	70
		49657	MVR400/VBU	6	0	Clear, Vertical Base Up ±15°	M59	41000	25500	20000	11⅝	7	4000	65
		49656	MVR400/C/VBU	6	0	Coated, Vertical Base Up ±15°	M59	41000	25000	20000	11⅝	7	3700	70
		49655	MVR400/VBD	6	0	Clear, Vertical Base Down ±15°	M59	41000	25500	20000	11⅝	7	4000	65
BT28	Mog	40335	MVR400/VBU/BT28	6	E	Clear, Vertical Base Up ±15°, Compact Bulb	M59	41000	25500	20000	11⅝	7	4000	65
ED37	Mog	20931	☞ MVR400/SP30/VBU	6	0	RE730 Phosphor Coating, Vertical Base Up ±15°	M59	34000	20400	20000	11⅝	7	3200	70
		13923	MVR400/VBU/XHO	6	0	Clear, Vertical Base Up ±15°	M59	44000	27400	20000	11⅝	7	4000	65
		13924	MVR400/C/VBU/XHO	6	0	Coated, Vertical Base Up ±15°	M59	43000	25800	20000	11⅝	7	3700	70
BT28	Mog	40201	MVR400/HOR/BT28	12	E	Clear, Horizontal Burn ±15°, Fits Standard or Position-oriented Socket, Compact Bulb	M59	37000	22000	20000	8⅜	5	4200	65
BT37	Mog	26218	MVR400/HOR/MOG	6	E	Clear, Horizontal Burn ±15°, Fits Standard or Position-oriented Socket	M59	38000	22500	20000	11½	7	4200	65
		26219	MVR400/C/HOR/MOG	6	E	Coated, Horizontal Burn ±15°, Fits Standard or Position-oriented Socket	M59	36800	22000	20000	11½	7	3900	70

† In actual applications, mean lumens will be higher for Metal Halide lamps operated on CW or CWA ballasts

To save energy costs, find the bulbs with the light output you need, then choose the one with the lowest watts.

() * All footnote references found at the end of this section. ➔ Reduced Wattage ☞ High Color Rendering. To convert inches to millimeters, multiply by 25.4.



Bulb	Base	Product Code	Lamp Description	Case Qty.	Fix. Req.	Additional Information	ANSI Ballast Type	Lumens Initial	Lumens Mean [†]	Rated Avg. Life Hours	MOL in.	LCL in.	Color Temp. K	CRI
HIGH OUTPUT MULTI-VAPOR® METAL HALIDE LAMPS (CONTINUED)														
1000 WATTS														
BT56	Mog	44835	MVR1000/VBU	6	0	Clear, Vertical Base Up ±15°	M47	115000	72300	12000	15 ³ / ₈	9 ¹ / ₂	3800	65
		13137	MVR1000/C/VBU	6	0	Coated, Vertical Base Up ±15°	M47	110000	66000	12000	15 ³ / ₈	9 ¹ / ₂	3400	70
1500 WATTS														
BT56	Mog	37405	MVR1500/HBU	6	E	Clear, Base Up to 15° Below Horizontal (16, 17)*	M48	155000 V 146000 H	126000 V 119000 H	3000 V 3000 H	15 ³ / ₈	9 ¹ / ₂	3600	65
		37406	MVR1500/HBD	6	E	Clear, Base Down to 15° Above Horizontal (16, 17)*	M48	155000 V 146000 H	126000 V 119000 H	3000 V 3000 H	15 ³ / ₈	9 ¹ / ₂	3600	65
BT56	Pos Mog	27246	MVR1500/HOR	6	E	Clear, Horizontal Burn ±60°, Position-oriented Socket Required (17)*	M48	162000	132000	3000	15 ³ / ₈	9 ¹ / ₂	3400	65
1650 WATTS														
BT56	Pos Mog	25532	MVR1650/HOR	6	E	Clear, Horizontal Burn ±60°, Position-oriented Socket Required (17)*	M112	177000	145000	3000	15 ³ / ₈	9 ¹ / ₂	3200	65
PROTECTED HIGH OUTPUT MULTI-VAPOR® METAL HALIDE LAMPS														
32 WATTS														
ED17	Med	12651	MXR32/C/VBD/O	6	0	Coated, Vertical Base Down ±15°	M100	2400	1700	10000	5 ⁷ / ₁₆	3 ⁷ / ₁₆	3200	70
		16469	MXR32/C/VBU/O	6	0	Coated, Vertical Base Up ±15°	M100	2400	1700	10000	5 ⁷ / ₁₆	3 ⁷ / ₁₆	3200	70
70 WATTS														
ED17	Med	12377	MXR70/U/MED/O	6	0	Clear	M98	5500	3500	12000	5 ⁷ / ₁₆	3 ⁷ / ₁₆	3200	70
		12577	MXR70/C/U/MED/O	6	0	Coated	M98	5300	3300	12000	5 ⁷ / ₁₆	3 ⁷ / ₁₆	3200	70
100 WATTS														
ED17	Med	12381	MXR100/U/MED/O	6	0	Clear	M90	9000	6200	15000	5 ⁷ / ₁₆	3 ⁷ / ₁₆	3200	70
		12579	MXR100/C/U/MED/O	6	0	Coated	M90	8500	5900	15000	5 ⁷ / ₁₆	3 ⁷ / ₁₆	3200	70
360 WATTS WATT-MISER® ENERGY-SAVING REPLACEMENT FOR 400W METAL HALIDE														
ED37	Mog	40056	MPR360/VBU/WM/O	6	0	Clear, Vertical Base Up ±15°, Shrouded Arc Tube, Watt-Miser® (32)*	M59	36000	24000	20000	11 ⁵ / ₁₆	7	4000	65
400 WATTS														
ED37	Mog	18708	MPR400/VBU/O	6	0	Clear, Vertical Base Up ±15°, Shrouded Arc Tube	M59	40000	24900	20000	11 ⁵ / ₁₆	7	3400	65
		13582	MPR400/C/VBU/O	6	0	Coated, Vertical Base Up ±15°, Shrouded Arc Tube	M59	38000	22800	20000	11 ⁵ / ₁₆	7	3200	70
CHROMAFIT™ MULTI-VAPOR® METAL HALIDE LAMPS (HPS RETROFIT LAMPS)														
250 WATTS														
ED28	Mog	12762	MVR250/VBU/R	12	E	Clear HPS Retrofit, Vertical Base Up ±15°	S50	18500	13900	10000	8 ¹ / ₄	5 ³ / ₄	4500	65
		12769	MVR250/C/VBU/R	12	E	Coated HPS Retrofit, Vertical Base Up ±15°	S50	18000	13000	10000	8 ¹ / ₄	5 ³ / ₄	4000	70
400 WATTS														
ED28	Mog	26851	MVR400/U/ED28/R	12	E	Clear HPS Retrofit, Compact Bulb	S51	36000 V 33100 H	22000 V 20200 H	20000 V 15000 H	8 ⁵ / ₁₆	5	4000	65
ED37	Mog	12770	MVR400/VBU/R	6	0	Clear HPS Retrofit, Vertical Base Up ±15°	S51	37600	22600	20000	11 ¹ / ₂	5 ³ / ₄	4500	65
		12772	MVR400/C/VBU/R	6	0	Coated HPS Retrofit, Vertical Base Up ±15°	S51	35700	21400	20000	11 ¹ / ₂	5 ³ / ₄	4000	70

[†] In actual applications, mean lumens will be higher for Metal Halide lamps operated on CW or CWA ballasts

To save energy costs, find the bulbs with the light output you need, then choose the one with the lowest watts.

(*) * All footnote references found at the end of this section. ➤ Reduced Wattage Ⓞ High Color Rendering. To convert inches to millimeters, multiply by 25.4.

High Intensity Discharge Lamps



Bulb	Base	Product Code	Lamp Description	Case Qty.	Fix. Req.	Additional Information	ANSI Ballast Type	Lumens Initial	Lumens Mean†	Rated Avg. Life Hours	MOL in.	LCL in.	Color Temp. K	CRI
I-LINE MULTI-VAPOR® METAL HALIDE LAMPS (MERCURY RETROFIT LAMPS)														
325 WATTS WATT-MISER® ENERGY-SAVING REPLACEMENT FOR 400W MERCURY														
ED37	Mog	10687	MVR325/I/U/WM	6	V	Clear, Energy-saving Retrofit for 400W Mercury, Watt-Miser®	H33	28000 V 25800 H	13300 V 12200 H	20000 V 10000 H	11 ⁵ / ₁₆	7	4000	65
		10688	MVR325/C/I/U/WM	6	V	Coated, Energy-saving Retrofit for 400W Mercury, Watt-Miser®	H33	26300 V 24200 H	12900 V 11800 H	20000 V 10000 H	11 ⁵ / ₁₆	7	3700	70
400 WATTS														
ED37	Mog	43817	MVR400/I/U	6	V	Clear, Retrofit for 400W Mercury	H33 or M59	36000 V 33100 H	24000 V 22100 H	15000 V 10000 H	11 ⁵ / ₁₆	7	4000	65
		43818	MVR400/C/I/U	6	V	Coated, Retrofit for 400W Mercury	H33 or M59	35000 V 32200 H	21000 V 19300 H	15000 V 10000 H	11 ⁵ / ₁₆	7	3700	70
950 WATTS ENERGY-SAVING REPLACEMENT FOR 1000W MERCURY														
BT56	Mog	39097	MVR950/I/VBU	6	0	Clear, Energy-saving Retrofit for 1000W Mercury, Vertical Base Up ±15°	H36 or M47	100000	62900	12000	15 ¹ / ₁₆	9 ¹ / ₂	3800	65
SAF-T-GARD® SELF-EXTINGUISHING MULTI-VAPOR® METAL HALIDE LAMPS														
400 WATTS														
ED37	Mog	11146	MVT400/I/U	6	V	Clear, Retrofit for 400W Mercury	H33 or M59	36000 V 33100 H	24000 V 22100 H	15000 V 10000 H	11 ⁵ / ₁₆	7	4000	65
		11119	MVT400/C/I/U	6	V	Coated, Retrofit for 400W Mercury	H33 or M59	35000 V 32200 H	21000 V 19300 H	15000 V 10000 H	11 ⁵ / ₁₆	7	3700	70
		11144	MVT400/VBU	6	0	Clear, Vertical Base Up ±15°	M59	41000	25500	20000	11 ⁵ / ₁₆	7	4000	65
		11145	MVT400/C/VBU	6	0	Coated, Vertical Base Up ±15°	M59	41000	22000	20000	11 ⁵ / ₁₆	7	3700	70
ARCSTREAM™ METAL HALIDE LAMPS														
70 WATTS														
T6	R7s	17443	ARC70/TD/730/R7S	12	E	Clear, Horizontal ±45°	M85	6000	4800	6000	4 ¹ / ₁₆		3000	75
		34592	ARC70/TD/742/R7S	12	E	Clear, Horizontal ±45°	M85	6000	4500	6000	4 ¹ / ₁₆		4200	75
150 WATTS														
Capsule	BiPin GY9.5	34813	CSS150/CAP/50	10	E	Clear, Disco Lamp	M81	10000	8000	1000	1 ³ / ₈	1 ¹ / ₈	5000	80
T6	BiPin G12	21053	ARC150/T/U/830/G12	10	E	Clear	M81	12000	9500	6000	3	2 ¹ / ₄	3000	80
		21054	ARC150/T/U/840/G12	10	E	Clear	M81	11500	10500	6000	3	2 ¹ / ₄	4000	80
T7	R7s	30095	ARC150/TD/730/R7S-24	12	E	Clear, Horizontal ±45°	M81	13000	11000	6000	5 ³ / ₈		3000	75
		17445	ARC150/TD/742/R7S-24	12	E	Clear, Horizontal ±45°	M81	12000	10000	6000	5 ³ / ₈		4200	75
PAR64	Ex Mog End Pr	30080	MBI150/PAR64/30M	1	0	Clear, Medium Beam, 13° Beam Spread, 50,000 CBCP	M81	11500	9000	6000	5 ¹ / ₄		3000	80
		21285	MBI150/PAR64/30N	1	0	Clear, Narrow Beam, 3° Beam Spread, 300,000 CBCP	M81	11500	9000	6000	5 ¹ / ₄		3000	80
250 WATTS														
T15	Mog	26683	ARC250/T/H/960/E39	12	E	Clear, Horizontal ±45°, Daylight Color	M80	19000	13300	10000	8 ³ / ₈	5 ³ / ₈	6000	90
400 WATTS														
ED18	Mog	26685	KRC400/T/H/960/E39	12	E	Clear, Horizontal ±45°, Daylight Color	(40)*	25000	17500	10000	10 ¹ / ₂	6 ³ / ₄	6000	90

† In actual applications, mean lumens will be higher for Metal Halide lamps operated on CW or CWA ballasts

To save energy costs, find the bulbs with the light output you need, then choose the one with the lowest watts.

(*) * All footnote references found at the end of this section. ⚡ Reduced Wattage ⚡ High Color Rendering. To convert inches to millimeters, multiply by 25.4.



Bulb	Base	Product Code	Lamp Description	Case Qty.	Fix. Req.	Additional Information	ANSI Ballast Type	Lumens Initial	Lumens Mean†	Rated Avg. Life Hours	MOL in.	LCL in.	Temp. K	Color CRI
ARCSTREAM™ METAL HALIDE LAMPS (Continued)														
1000 WATTS														
PAR64	G38	29333	SPL1000/PAR64/840/G38	1	E	Clear, Narrow Spot, 6° Beam Spread, 1,350,000 CBCP, Spotlight	(38)*	63000	53000	3500	6 ⁷ / ₈	4000	4000	80
		29336	SPL1000/PAR64/840/HR/G38	1	E	Clear, Narrow Spot, 6° Beam Spread, 1,350,000 CBCP, Hot Restrike, Spotlight	(38)*	63000	53000	3500	6 ⁷ / ₈	4000	4000	80
1500 WATTS														
T7	Rx7s	30061	SPL1500/L/H/652/RX7SM	1	E	Frosted, Horizontal ±15°, Spotlight	(37)*	120000	90000	6000	10 ¹ / ₈	5	5200	65
LUCALOX® HIGH PRESSURE SODIUM LAMPS														
35 WATTS														
B17	Med	11668	LU35/MED	6	0	Clear	S76	2250	2025	16000	5 ⁷ / ₁₆	3 ⁷ / ₁₆	1900	22
		26420	LU35/MED/CP	4	0	Clear, Consumer Pack	S76	2250	2025	16000	5 ⁷ / ₁₆	3 ⁷ / ₁₆	1900	22
		11669	LU35/D/MED	6	0	Diffuse	S76	2150	1935	16000	5 ⁷ / ₁₆	3 ⁷ / ₁₆	1900	22
50 WATTS														
B17	Med	11345	LU50/MED	6	0	Clear	S68	4000	3600	24000 +	5 ⁷ / ₁₆	3 ⁷ / ₁₆	1900	22
		26421	LU50/MED/CP	4	0	Clear, Consumer Pack	S68	4000	3600	24000 +	5 ⁷ / ₁₆	3 ⁷ / ₁₆	1900	22
		11347	LU50/D/MED	6	0	Diffuse	S68	3800	3420	24000 +	5 ⁷ / ₁₆	3 ⁷ / ₁₆	1900	22
ED23 ¹ / ₂	Mog	44975	LU50	12	0	Clear	S68	4000	3600	24000 +	7 ³ / ₄	5	1900	22
		26425	LU50/CP	4	0	Clear, Consumer Pack	S68	4000	3600	24000 +	7 ³ / ₄	5	1900	22
		45006	LU50/D	12	0	Diffuse	S68	3800	3420	24000 +	7 ³ / ₄	5	1900	22
70 WATTS														
B17	Med	11339	LU70/MED	6	0	Clear	S62	6400	5450	24000 +	5 ⁷ / ₁₆	3 ⁷ / ₁₆	1900	22
		26422	LU70/MED/CP	4	0	Clear, Consumer Pack	S62	6400	5450	24000 +	5 ⁷ / ₁₆	3 ⁷ / ₁₆	1900	22
		11340	LU70/D/MED	6	0	Diffuse	S62	5950	5050	24000 +	5 ⁷ / ₁₆	3 ⁷ / ₁₆	1900	22
ED23 ¹ / ₂	Mog	44033	LU70	12	0	Clear	S62	6400	5450	24000 +	7 ³ / ₄	5	1900	22
		26426	LU70/CP	4	0	Clear, Consumer Pack	S62	6400	5450	24000 +	7 ³ / ₄	5	1900	22
		44035	LU70/D	12	0	Diffuse	S62	5950	5050	24000 +	7 ³ / ₄	5	1900	22
		19264	LU70/SBY/LL	12	0	Clear, Standby Longlife, Dual Arc Tube	S62	6400	5050	40000	7 ³ / ₄	5	1900	22
100 WATTS														
B17	Med	13250	LU100/MED	6	0	Clear	S54	9500	8550	24000 +	5 ¹ / ₂	3 ⁷ / ₁₆	2000	22
		26423	LU100/MED/CP	4	0	Clear, Consumer Pack	S54	9500	8550	24000 +	5 ¹ / ₂	3 ⁷ / ₁₆	2000	22
		13251	LU100/D/MED	6	0	Diffuse	S54	8800	7920	24000 +	5 ¹ / ₂	3 ⁷ / ₁₆	2000	22
ED23 ¹ / ₂	Mog	44037	LU100	12	0	Clear	S54	9500	8550	24000 +	7 ³ / ₄	5	2000	22
		26427	LU100/CP	4	0	Clear, Consumer Pack	S54	9500	8550	24000 +	7 ³ / ₄	5	2000	22
		44038	LU100/D	12	0	Diffuse	S54	8800	7920	24000 +	7 ³ / ₄	5	2000	22
		19265	LU100/SBY/LL	12	0	Clear, Standby Longlife, Dual Arc Tube	S54	9500	8190	40000	7 ³ / ₄	5	2000	22

† In actual applications, mean lumens will be higher for Metal Halide lamps operated on CW or CWA ballasts

To save energy costs, find the bulbs with the light output you need, then choose the one with the lowest watts.
 () * All footnote references found at the end of this section. ➤ Reduced Wattage ➤ High Color Rendering. To convert inches to millimeters, multiply by 25.4.

High Intensity Discharge Lamps



Bulb	Base	Product Code	Lamp Description	Case Qty.	Fix. Req.	Additional Information	ANSI Ballast Type	Lumens Initial	Lumens Mean	Rated Avg. Life Hours	MOL in.	LCL in.	Temp. K	Color CRI
LUCALOX® HIGH PRESSURE SODIUM LAMPS (Continued)														
150 WATTS														
B17	Med	13252	LU150/MED	6	0	Clear	S55	16000	14400	24000 +	5 ³ / ₄	3 ¹ / ₂	2000	22
		26424	LU150/MED/CP	4	0	Clear, Consumer Pack	S55	16000	14400	24000 +	5 ³ / ₄	3 ¹ / ₂	2000	22
		13253	LU150/D/MED	6	0	Diffuse	S55	15000	13500	24000 +	5 ³ / ₄	3 ¹ / ₂	2000	22
ED23 ¹ / ₂	Mog	44043	LU150/55	12	0	Clear	S55	16000	14400	24000 +	7 ³ / ₄	5	2000	22
		26429	LU150/55/CP	4	0	Clear, Consumer Pack	S55	16000	14400	24000 +	7 ³ / ₄	5	2000	22
		44045	LU150/55/D	12	0	Diffuse	S55	15000	13500	24000 +	7 ³ / ₄	5	2000	22
		19266	LU150/55/SBY/LL	12	0	Clear, Standby Longlife, Dual Arc Tube	S55	16000	14000	40000	7 ³ / ₄	5	2000	22
ED28	Mog	44243	LU150/100	12	0	Clear	S56	15000	13500	24000 +	8 ⁵ / ₁₆	5	2000	22
		18245	LU150/100/D	12	0	Diffuse	S56	14000	12600	24000 +	8 ⁵ / ₁₆	5	2000	22
200 WATTS														
ED18	Mog	44206	LU200	12	0	Clear	S66	22000	19800	24000 +	9 ³ / ₄	5 ³ / ₄	2100	22
		23431	LU200/SBY/LL	12	0	Clear, Standby Longlife, Dual Arc Tube	S66	21500	18150	40000	9 ³ / ₄	5 ³ / ₄	2100	22
250 WATTS														
ED18	Mog	44047	LU250	12	0	Clear	S50	28000	27000	24000 +	9 ³ / ₄	5 ³ / ₄	2100	22
		26430	LU250/CP	4	0	Clear, Consumer Pack	S50	28000	27000	24000 +	9 ³ / ₄	5 ³ / ₄	2100	22
		44049	LU250/S	12	0	Clear, Extra Light	S50	30000	28000	24000 +	9 ³ / ₄	5 ³ / ₄	2100	22
		19270	LU250/SBY/LL	12	0	Clear, Standby Longlife, Dual Arc Tube	S50	27500	24750	40000	9 ³ / ₄	5 ³ / ₄	2100	22
ED28	Mog	44051	LU250/D	12	0	Diffuse	S50	26000	23400	24000 +	9	5	2100	22
310 WATTS														
ED18	Mog	44053	LU310	12	0	Clear	S67	37000	33300	24000 +	9 ³ / ₄	5 ³ / ₄	2100	22
400 WATTS														
ED18	Mog	44054	LU400	12	0	Clear	S51	51000	45000	24000 +	9 ³ / ₄	5 ³ / ₄	2100	22
		26431	LU400/CP	4	0	Clear, Consumer Pack	S51	51000	45000	24000 +	9 ³ / ₄	5 ³ / ₄	2100	22
		19272	LU400/SBY/LL	12	0	Clear, Standby Longlife, Dual Arc Tube	S51	50000	45000	40000	9 ³ / ₄	5 ³ / ₄	2100	22
ED28	Mog	44056	LU400/D	6	0	Diffuse	S51	47500	42750	24000 +	11 ⁵ / ₁₆	7	2100	22
T7	Rx7s	30244	LU400/TD	10	0	Clear, Double-ended, Horizontal Burn ±20°	S51	43000	37300	24000	10 ¹ / ₈		2000	25
600 WATTS														
T15	Mog	27187	LU600/T	12	0	Clear	S106	90000	81000	12000 +	11 ¹ / ₁₆	6 ⁵ / ₈	2000	25
750 WATTS														
ED37	Mog	14682	LU750	6	0	Clear	S111	110000	99000	24000 +	11 ¹ / ₂	6 ³ / ₄	2100	22
1000 WATTS														
E25	Mog	44058	LU1000	6	0	Clear	S52	140000	126000	24000 +	15 ¹ / ₁₆	8 ³ / ₄	2100	22
		27185	LU1000/SBY/LL	6	0	Clear, Standby Longlife, Dual Arc Tube	S52	127000	115000	40000	15 ¹ / ₁₆	8 ³ / ₄	2100	22
T7	Rx7s	30246	LU1000/TD	10	0	Clear, Double-ended, Horizontal Burn ±20°	S52	137500	118200	24000	13 ³ / ₁₆		2000	25



Bulb	Base	Product Code	Lamp Description	Case Qty.	Fix. Req.	Additional Information	ANSI Ballast Type	Lumens Initial	Lumens Mean	Rated Avg. Life Hours	MOL in.	LCL in.	Temp. K	Color CRI
ECOLUX® NC NON-CYCLING HIGH PRESSURE SODIUM LAMPS (TCLP COMPLIANT)														
70 WATTS														
ED23 1/2	Mog	14672	LU70/ECO/NC	12	0	Clear, Non-Cycling	S62	6300	5370	24000	7 3/4	5	1900	23
100 WATTS														
ED23 1/2	Mog	14673	LU100/ECO/NC	12	0	Clear, Non-Cycling	S54	10500	8550	24000	7 3/4	5	2000	23
150 WATTS														
ED23 1/2	Mog	40390	LU150/ECO/NC	12	0	Clear, Non-Cycling	S55	16000	14400	24000	7 3/4	5	2000	23
250 WATTS														
ED18	Mog	14674	LU250/ECO/NC	12	0	Clear, Non-Cycling	S50	29000	27500	24000	9 3/4	5 3/4	2000	30
400 WATTS														
ED18	Mog	14675	LU400/ECO/NC	12	0	Clear, Non-Cycling	S54	54000	48000	24000	9 3/4	5 3/4	2100	30
DELUXE LUCALOX® HIGH PRESSURE SODIUM LAMPS														
70 WATTS														
B17	Med	16611	LU70/DX/MED	6	0	Clear, Improved CRI	S62	3800	3040	10000	5 1/2	3 1/2	2200	65
150 WATTS														
B17	Med	18094	LU150/DX/MED	6	0	Clear, Improved CRI	S55	10500	9135	15000	5 3/4	3 1/2	2200	65
ED23 1/2	Mog	18092	LU150/55/DX	12	0	Clear, Improved CRI	S55	10500	9135	15000	7 3/4	5	2200	65
250 WATTS														
ED18	Mog	11785	LU250/DX	12	0	Clear, Improved CRI	S50	22500	20700	15000	9 3/4	5 3/4	2200	65
400 WATTS														
ED28	Mog	19650	LU400/DX	12	0	Clear, Improved CRI	S51	37400	34400	15000	9	5 5/16	2200	70
E-Z LUX® HIGH PRESSURE SODIUM LAMPS (MERCURY RETROFIT)														
150 WATTS														
ED28	Mog	49943	LUH150/EZ	12	0	Clear, Energy-saving Retrofit for 175W Mercury	H39	12500	12000	13000	9	5	1900	22
215 WATTS														
ED28	Mog	49939	LUH215/EZ	12	0	Clear, Energy-saving Retrofit for 250W Mercury	H37	20200	18600	12000	9	5	1900	22
360 WATTS														
BT37	Mog	18012	LUH360/EZ	6	0	Clear, Energy-saving Retrofit for 400W Mercury	H33	45000	40500	24000	11 5/16	7 1/8	2100	25
SOX LOW PRESSURE SODIUM LAMPS														
18 WATTS														
T16	B22d	21294	SOX-18	16	E	Clear, Horizontal Burn ±20° or Vertical Base Up ±15°	L69	1800	1570	18000	8 1/2	5 3/8	1800	0
35 WATTS														
T16	B22d	21296	SOX-35	16	E	Clear, Horizontal Burn ±20° or Vertical Base Up ±15°	L70	4600	4000	18000	12 1/4	7 1/4	1800	0
55 WATTS														
T16	B22d	21297	SOX-55	16	E	Clear, Horizontal Burn ±20° or Vertical Base Up ±15°	L71	7650	6655	18000	16 3/4	9 1/2	1800	0
90 WATTS														
T21	B22d	21298	SOX-90	9	E	Clear, Horizontal Burn ±20°	L72	12750	11095	16000	20 3/4	11 1/2	1800	0

To save energy costs, find the bulbs with the light output you need, then choose the one with the lowest watts.
 () * All footnote references found at the end of this section. ⚡ Reduced Wattage ⚙ High Color Rendering. To convert inches to millimeters, multiply by 25.4.

High Intensity Discharge Lamps



Bulb	Base	Product Code	Lamp Description	Case Qty.	Fix. Req.	Additional Information	ANSI Ballast Type	Lumens Initial	Lumens Mean	Rated Avg. Life Hours	MOL in.	LCL in.	Temp. K	Color CRI
SOX LOW PRESSURE SODIUM LAMPS (Continued)														
135 WATTS														
T21	B22d	21299	SOX-135	9	E	Clear, Horizontal Burn ±20°	L73	22000	19140	16000	30 ¹ / ₂	16 ³ / ₈	1800	0
180 WATTS														
T21	B22d	30203	SOX-180	9	E	Clear, Horizontal Burn ±20°	L74	32000	27800	16000	44 ¹ / ₈	22 ⁷ / ₈	1800	0
MERCURY LAMPS														
40/50 WATTS														
B17	Med	12460	HR40/50DX45	5	0	40W on H45 Ballast, 50W on H46 Ballast, Deluxe White	H45 H46	1140 1575	910 1250	6000 6000	5 ¹ / ₈	3 ¹ / ₈	3900	50
75 WATTS														
B17	Med	12461	HR75DX43	5	0	Deluxe White	H43	2700	2250	16000	5 ⁷ / ₁₆	3 ¹ / ₂	3900	50
100 WATTS														
A23 ¹ / ₂	Med	12464	HR100A38/A23	5	0	Clear	H38	3700	2400	18000	5 ⁷ / ₁₆	3 ¹ / ₂	5700	15
		12467	HR100DX38/A23	5	0	Deluxe White	H38	4000	2600	18000	5 ⁷ / ₁₆	3 ¹ / ₂	3800	50
B17	Med	17113	HR100DX38/MED	5	0	Deluxe White	H38	4000	2600	18000	5 ⁷ / ₁₆	3 ¹ / ₂	3900	50
ED23 ¹ / ₂	Mog	12471	HR100A38	5	0	Clear	H38	3850	2500	24000 +	7 ¹ / ₂	5	5700	15
		22575	HR100DX38	12	0	Deluxe White	H38	4000	2600	24000 +	7 ¹ / ₂	5	3900	50
		26437	HR100DX38/CP	4	0	Deluxe White, Consumer Pack	H38	4000	2600	24000 +	7 ¹ / ₂	5	3900	50
PAR38	Admed Skrt	24040	HR100PSP44	12	0	PAR Spot, Landscape & Black Light, 15° Beam Spread	H44	2450	1700	12000	5 ⁷ / ₁₆		5700	15
PAR38	Med Skirt	19648	HR100PSP44/MED	12	0	PAR Spot, Landscape & Black Light, 15° Beam Spread	H44	2450	1700	12000	5 ⁷ / ₁₆		5700	15
		19647	HR100PFL44/MED	12	0	PAR Flood, Landscape & Black Light, 75° Beam Spread	H44	2450	1700	12000	5 ⁷ / ₁₆		5700	15
R40	Med	36238	HR100RFL38	12	0	Reflector Flood, 48° Beam Spread	H38	2450	2000	24000 +	7		5700	15
		36495	HR100RDXFL38	12	0	Deluxe White, Reflector WFL, 140° Beam Spread	H38	2450	2050	24000 +	7		3900	50
175 WATTS														
ED28	Mog	24048	HR175A39	12	0	Clear	H39	7850	6830	24000 +	8 ¹ / ₄	5	5700	15
		26440	HR175A39/CP	4	0	Clear, Consumer Pack	H39	7850	6830	24000 +	8 ¹ / ₄	5	5700	15
		24062	HR175DX39	12	0	Deluxe White	H39	7800	6800	24000 +	8 ¹ / ₄	5	3900	50
		26439	HR175DX39/CP	4	0	Deluxe White, Consumer Pack	H39	7800	6800	24000 +	8 ¹ / ₄	5	3900	50
R40	Med	24058	HR175RFL39	12	0	Clear, Reflector Flood, 40° Beam Spread	H39	5700	4800	24000 +	7		5700	15
		33026	HR175RDXFL39	12	0	Deluxe White, Reflector WFL, 120° Beam Spread	H39	5700	4350	24000 +	7		3900	50
R40	Mog	36445	HR175RFL39/M	12	0	Clear, Reflector Flood, 40° Beam Spread	H39	5700	4800	24000 +	7 ¹ / ₂		5700	15
250 WATTS														
ED28	Mog	24068	HR250A37	12	0	Clear	H37	11000	8250	24000	8 ¹ / ₄	5	5700	15
		32127	HR250DX37	12	0	Deluxe White	H37	11200	8400	24000 +	8 ¹ / ₄	5	3900	50



Bulb	Base	Product Code	Lamp Description	Case Qty.	Fix. Req.	Additional Information	ANSI Ballast Type	Lumens Initial	Lumens Mean	Rated Avg. Life Hours	MOL in.	LCL in.	Temp. K	CRI
MERCURY LAMPS (Continued)														
400 WATTS														
BT37	Mog	32313	HR400DX33/BT	6	0	Deluxe White	H33	22600	14400	24000 + 11 ⁵ / ₁₆	7	3900	50	
ED37	Mog	23974	HR400A33	6	0	Clear	H33	21000	13400	24000 + 11 ⁵ / ₁₆	7	5700	15	
		23998	HR400DX33	6	0	Deluxe White	H33	22600	14400	24000 + 11 ⁵ / ₁₆	7	3900	50	
R52	Mog	33879	HR400RDX33	6	0	Reflector, Deluxe White, 160° Beam Spread	H33	20800	13400	24000 + 11 ³ / ₄		3900	50	
R60	Mog	33938	HR400RDXFL33	6	0	Reflector WFL, Deluxe White, Clear Face, 110° Beam Spread	H33	15500	8950	24000 + 10 ¹ / ₈		3900	50	
T16	Mog	14873	H400A33/T16	6	0	Clear	H33	20000	18200	12000	11	7	5700	15
1000 WATTS														
BT56	Mog	24171	HR1000A36	6	0	Clear	H36	57000	28500	24000 + 15 ¹ / ₁₆	9 ¹ / ₂	5700	15	
		24191	HR1000DX36	6	0	Deluxe White	H36	58000	29000	24000 + 15 ¹ / ₁₆	9 ¹ / ₂	3900	50	
		32733	HR1000DX34	6	0	Deluxe White (28)*	H34	58300	29200	16000	15 ¹ / ₁₆	9 ³ / ₈	3900	50
SAF-T-GARD® MERCURY LAMPS														
175 WATTS														
ED28	Mog	43391	HT175DX39	12	0	Deluxe White	H39	7800	6800	16000	8 ¹ / ₄	5	3900	50
400 WATTS														
ED37	Mog	43363	HT400DX33	6	0	Deluxe White	H33	22600	14400	24000	11 ⁵ / ₁₆	7	3900	50
E-Z MERC® SELF-BALLASTED LAMPS (INCANDESCENT RETROFIT)														
160 WATTS														
ED24	Med	45178	HSB160/M	24	0	Deluxe White, 120V (9)*		2300	1600	12000	7	4 ⁹ / ₁₆	3900	50
250 WATTS														
ED28	Med	45174	HSB250/M	12	0	Deluxe White, 120V (9)*		5000	3750	12000	8 ¹ / ₂	5 ³ / ₁₆	3900	50
ED28	Mog	45176	HSB250	12	0	Deluxe White, 120V (9)*		5000	3750	12000	8 ¹ / ₂	5 ³ / ₁₆	3900	50
450 WATTS														
BT37	Mog	40122	HSB450	6	0	Deluxe White, 120V (9)*		9100	8280	16000	11 ¹³ / ₃₂	7 ³ / ₈	3900	50
750 WATTS														
R57	Mog	44012	HSB750R/120	6	0	Deluxe White, Reflector Flood, 120V, 130° Beam Spread (9)*		14000	11200	16000	12 ³ / ₄	8 ³ / ₈	3900	50

To save energy costs, find the bulbs with the light output you need, then choose the one with the lowest watts.
 (*) * All footnote references found at the end of this section. Reduced Wattage High Color Rendering. To convert inches to millimeters, multiply by 25.4.

High Intensity Discharge Lamps



Bulb	Base	Product Code	Lamp Description	Case Qty.	Fix. Req.	Additional Information	ANSI Ballast Type	Lumens		Rated Avg. Life Hours	MOL		LCL		Color Temp.		
								Initial	Mean		in.	(mm)	in.	(mm)	K	CR1	
EXPORT LAMPS																	
METAL HALIDE																	
ED17	E27	16893	MXR32/C/VBU/0/27	6	0	Coated, Vertical Base Up ±15°	M100	2400	1700	10000	5 1/2 (140)	3 1/2 (89)	3200	70			
BD17	E27	18686	MXR100/U/27	6	E	Clear		9000	6200	15000	5 1/2 (140)	3 1/2 (89)	3200	70			
		18684	MXR100/C/U/27	6	E	Coated		8500	5900	15000	5 1/2 (140)	3 1/2 (89)	3200	70			
ED23 1/2	E40	18952	MXR175/C/VBU/40	6	E	Coated, Vertical Base Up ±15°, Integral Ignitor (13)*		16300	12500	10000	7 7/8 (200)	5 1/8 (130)	3200	70			
ED28	E40	47762	MVR175/U/40	12	E	Clear (14)*		13600	8600	10000	8 1/2 (216)	5 1/8 (130)	4000	65			
		47763	MVR175/C/U/40	12	E	Coated (14)*		12900	8200	10000	8 1/2 (216)	5 1/8 (130)	3900	70			
		17714	MVR175/SP30/U/40	12	E	RE730 Phosphor Coating (14)*		12000	7600	10000	8 1/2 (216)	5 1/8 (130)	3000	70			
		44542	MVR250/U/40	12	E	Clear (14)*		20800	13500	10000	8 1/2 (216)	5 1/8 (130)	4200	65			
		44543	MVR250/C/U/40	12	E	Coated (14)*		19800	12600	10000	8 1/2 (216)	5 1/8 (130)	3900	70			
		17715	MVR250/SP30/U/40	12	E	RE730 Phosphor Coating (14)*		18000	11500	10000	8 1/2 (216)	5 1/8 (130)	3000	70			
ED37	E40	43907	MVR400/U/40	6	V	Clear (14)*		36000	24000	20000	11 5/8 (295)	7 3/16 (183)	4000	65			
		43908	MVR400/C/U/40	6	V	Coated (14)*		35000	21000	20000	11 5/8 (295)	7 3/16 (183)	3700	70			
		17716	MVR400/SP30/U/40	6	V	RE730 Phosphor Coating (14)*		31000	18600	20000	11 5/8 (295)	7 3/16 (183)	3000	70			
		49860	MVR400/VBU/40	6	0	Clear, Vertical Base Up ±15°		41000	25500	20000	11 5/8 (295)	7 3/16 (183)	4000	65			
		49857	MVR400/C/VBU/40	6	0	Coated, Vertical Base Up ±15°		41000	25000	20000	11 5/8 (295)	7 3/16 (183)	3700	70			
		21440	MVR400/SP30/VBU/40	6	0	RE730 Phosphor Coating, Vertical Base Up ±15°		34000	20400	20000	11 5/8 (295)	7 3/16 (183)	3200	70			
BT56	E40	41828	MVR1000/U/40	6	V	Clear		105000	66000	12000	15 5/32 (385)	9 5/32 (233)	4000	65			
		41829	MVR1000/C/U/40	6	V	Coated		99800	59900	12000	15 5/32 (385)	9 5/32 (233)	3400	70			
LUCALOX® HIGH PRESSURE SODIUM																	
E21	E27	10405	LU70/90/27	12	0	Clear		6000	5400	24000 +	6 3/8 (160)	4 5/32 (106)	1900	22			
		27224	LU70/90/D/27	12	0	Diffuse		5800	5220	24000 +	6 3/8 (160)	4 5/32 (106)	1900	22			
ED23 1/2	E40	27230	LU100/100/D/40	12	0	Diffuse		9200	7820	24000 +	7 5/16 (186)	5 (127)	2000	22			
		44044	LU150/55/40	12	0	Clear		16000	14400	24000 +	7 15/16 (202)	5 5/32 (131)	2000	22			
T14 1/2	E40	27223	LU150/100/40	12	0	Clear		15000	13500	24000 +	8 1/4 (210)	5 5/32 (131)	2000	22			
ED28	E40	27228	LU150/100/D/40	12	0	Diffuse		14000	12600	24000 +	8 7/16 (214)	5 5/32 (131)	2000	22			
ED18	E40	44048	LU250/40	12	0	Clear		28000	27000	24000 +	9 15/16 (252)	5 29/32 (150)	2100	22			
ED28	E40	27226	LU250/D/40	12	0	Clear		26000	23400	24000 +	9 1/8 (232)	5 3/8 (137)	2100	22			
ED18	E40	44055	LU400/40	12	0	Clear		51000	45000	24000 +	9 15/16 (252)	5 29/32 (150)	2100	22			
ED37	E40	27229	LU400/D/40	6	0	Diffuse		47500	42750	24000 +	11 1/2 (292)	7 3/16 (183)	2100	22			
E25	E40	44059	LU1000/40	6	0	Clear		140000	126000	24000 +	15 3/16 (386)	8 13/16 (224)	2100	22			
T18	E40	44247	LU1000/T18/40	6	0	Clear		140000	126000	24000 +	15 1/16 (383)	8 13/16 (224)	2100	22			
E-Z LUX® LUCALOX® HIGH PRESSURE SODIUM (MERCURY RETROFIT)																	
ED23 1/2	E27	11683	LUH110/D/27	12	0	Diffuse, Energy-saving Retrofit for 125W Mercury		8800	7920	10000	6 7/8 (175)	4 5/16 (110)	1900	22			
ED28	E40	49941	LUH215/D/EZ/40	12	0	Diffuse, Energy-saving Retrofit for 250W Mercury		20200	18600	12000	9 1/8 (232)	5 7/32 (133)	1900	22			
MERCURY																	
ED28	E40	32372	HR250DX37/40	12	0	Deluxe White		11200	8400	24000 +	8 3/8 (213)	5 5/32 (131)	3900	50			
ED37	E40	32294	HR400DX33/40	6	0	Deluxe White		22600	14400	24000	11 7/16 (291)	7 11/64 (182)	3900	50			
BT56	E40	12017	HR1000DX34/40	6	0	Deluxe White		58300	29200	16000	15 1/16 (383)	9 3/8 (238)	3900	50			



GENERAL INFORMATION

FIXTURE REQUIREMENTS

HID lamps have fixture requirements that must be followed. The following three codes identify the appropriate fixture for a particular lamp. Lamps having an "O" code can be operated in an "Open or Enclosed" fixture. Lamps with a "V" code can be used in open fixtures only if operated in a vertical ± 15 degrees burn position. Lamps in all other burn positions must be suitably enclosed.

O = Open or Enclosed Fixtures

E = Enclosed Fixtures Only

V = Lamps operated in a vertical position (Base Up or Down), ± 15 degrees, can be used in an open fixture. Lamps burned in any other orientation must be used in "enclosed fixtures only".

Use in Enclosed Fixtures. "Enclosed" fixture means a fixture suitably enclosed and designed to contain fragments of hot quartz or glass (up to 1100° C) per UL Standard #1572 (if in doubt, contact your fixture manufacturer).

Use in Open Fixtures. For lamps operated in the vertical position $\pm 15^\circ$ that are not designated "Enclosed Fixtures Only," lamp may be used in an open or enclosed lighting fixture depending upon the application and operating environment. For example, if the lamp is located near combustible material or in an area which is unoccupied for extended periods, an enclosed fixture which can contain fragments of hot quartz or glass is recommended. For more information, contact your fixture manufacturer.

PROTECTION OF BULBS FROM MOISTURE

Outer bulbs of HID lamps are made of heat-resistant glass, designed to have strength and thermal-shock-resistant characteristics suitable for normal applications in typical luminaries. However, shielding of lamps must be provided to avoid bulb breakage that could result from direct contact with liquids (such as water) during operation.

RATED AVERAGE LIFE

Values are based on laboratory tests of a large number of representative lamps under controlled conditions, including operation at 10 hours per start on ballasts having specified electrical characteristics. Individual lamps or groups of lamps may, of course, vary from the Rated Average Life shown. Lamp operating conditions can also affect life. Where Rated Average Life is less than 24,000 hours, it is a MEDIAN value of life expectancy; that is, the total operating time at which, under normal operating conditions, 50% of any large group of initially installed lamps is expected to be still burning. Where Rated Average Life is 24,000+ hours, 67% of lamps are expected to be still burning at 24,000 hours. For cost-of-light calculations involving these lamps, if an estimated operating time is required at which 50% of the lamps will still be burning, a value of 28,500 hours is suggested. At burning cycles shorter than 10 hours per start, the median life will be shortened as follows:

5 hrs/start:	approx. life 75% of rating
2½ hrs/start:	approx. life 56% of rating
1¼ hrs/start:	approx. life 42% of rating

LUMENS— LUMENS LISTED ARE REFERENCE LUMENS

Rated average lamp lumens are obtained under controlled laboratory conditions in a prescribed burning position. **Initial Reference Lumens** refer to the lamp lumen output after 100-hours burning. **Mean Reference Lumens** refer to the lamp lumen output at the mean lumen point during lamp life. The mean lumen point occurs at 50% rated life for HPS and mercury lamps, and at 40% rated life for metal halide lamps. Lamp performance on typical systems under typical service conditions will vary from the reference lumen ratings.

High Intensity Discharge lighting systems are subject to a wide range of variations which may affect final lighting levels. As a result, lamp performance on actual systems may vary due to lamp orientation, ambient temperatures, ballast variations, line voltage and other reasons. Care must be taken when choosing a system to consider how these changes can affect your light levels both initially and at the mean lumen point.

BALLASTS

HID lamps (except E-Z-Merc®) require auxiliary ballast equipment designed to produce proper electrical values. Actual lamp watts may vary depending on ballast characteristics. For total system watts, add nominal ballast watts.

All Lucalox®, Mercury, and Metal Halide lamps (except I-Line) will start at ambient temperatures of -22°F (-30°C). I-Line Multi-Vapor® will start at ambient temperatures of 5°F (-15°C) when used on approved mercury ballasts.

START CHARACTERISTICS

Full light output does not occur immediately when power is applied. Instead, there is a time delay for the lamp to reach 90% total light output. The starting delay for High Pressure Sodium is 3-4 minutes, for Metal Halide 2-5 minutes, and for Mercury 5-7 minutes.

RESTART CHARACTERISTICS

With a power interruption of a half cycle or more, the arc will extinguish. When power is immediately reapplied, full light output does not occur immediately. For HPS lamps there is a delay of 1 minute to reach 90% total light output; however, Lucalox® LU1000 requires 2 minutes and E-Z Lux® lamps require 3 minutes to reach 90% total light output. For most Metal Halide lamps, including CMH™, when the power is immediately reapplied, there will be a delay of 10 to 15 minutes before the lamps reach the 90% light output level. PulseArc™ lamps restrike in <4 minutes. The restart delay for mercury lamps is 3 to 6 minutes to reach 90% total light output.

BURN POSITIONS AND CODES

Mercury and High Pressure Sodium lamps may be operated in any burn position and will still maintain their rated performance specifications. Metal Halide and Low Pressure Sodium lamps, however, are optimized for performance in specific burn positions, or may be restricted to certain burn positions for safety reasons.

- U = Universal burning position
- HBU = Horizontal -15° to Base Up
- HBD = Horizontal +15° to Base Down
- HOR = Horizontal $\pm 15^\circ$
- VBU = Vertical Base Up $\pm 15^\circ$
- VBD = Vertical Base Down $\pm 15^\circ$

If no special burn position is noted, the burn position is universal.



GENERAL INFORMATION (Continued)

HID COLOR

The color temperature and CRI listed in the tabular data are for reference purposes only. All high intensity discharge lamps exhibit some degree of lamp to lamp color variation and shift over life. These characteristics can be increased based on choice of fixture, ballast, burning position, and ambient conditions. Color variation can be greater than normal during the initial 100 hours of burning. Where color consistency is important, consider using ConstantColor® CMH™ for better performance (page 3-8). Contact your local GE Lighting representative for more information.

OPERATING NOTES

E-Z LUX® LAMPS

These high pressure sodium lamps should be operated only on certain mercury ballasts, as indicated below.

LUH110/EZ: use only with the following types of 125-watt mercury ballasts: high-reactance lag-type autotransformers or 220-volt or greater reactors.

LUH150/EZ: use only with the following types of H39 175-watt mercury ballasts: high-reactance lag-type autotransformers or 240-volt and 277-volt reactors. Do not use with CW (lead-type) or CWA ballasts.

LUH215/EZ: use only with the following types of H37 250-watt mercury ballasts: high reactance lag-type autotransformers or 240-volt and 277-volt reactors. Do not use with CW (lead-type) or CWA ballasts.

LUH360/EZ: use only with the following types of H33 400-watt mercury ballasts: high-reactance lag-type autotransformers, reactors, CWA auto regulators or CW regulators.

EXPORT BASE LAMPS (/27 AND /40)

Export only lamps have a non-domestic (non-U.S.) base and are not intended for use in the United States due to potential shock hazard. The lamps are identified by "/27" or "/40" at the end of the lamp description and comply with electrical characteristics defined by IEC standards.

MXR32 METAL HALIDE LAMP AND ELECTRONIC BALLAST

MXR32 lamps must be operated on GE Lighting's special, high power factor electronic ballast, HAL32/120 (page 3-8). Outside dimensions for the ballast are 9¼" long, 3⅝" wide and 1¾" high.

SAF-T-GARD® MULTI-VAPOR® AND SAF-T-GARD® MERCURY LAMPS

Caution: If the outer glass envelope of a Saf-T-Gard® lamp is broken, the arc tube will self-extinguish, but the supporting structure will still be electrically connected. Be sure power is off and the lamp has cooled before removing the lamp to avoid possible electrical shock from contact with the arc tube support and to avoid risk of burn from the hot arc tube.

ARCSTREAM™ METAL HALIDE LAMPS

Arcstream™ tubular-shaped lamps must be used in suitably-enclosed fixtures with UV-absorbing cover glass. Enclosed fixtures must be capable of containing fragments of hot quartz or glass (up to 1100°C) in the unusual event of the outer bulb shattering. Also see complete Warning and Caution Notices on metal halide lamps.

WARNING AND CAUTION NOTICES

METAL HALIDE LAMPS

The following operating instructions must be complied with to help avoid possible shattering and early failure of the lamp. Metal Halide lamps are constructed of an outer bulb with an internal arc tube made of quartz. The arc tube operates under high pressure at very high temperatures – as high as approximately 1100°C.

The arc tube and outer bulb may unexpectedly rupture due to internal causes or external factors such as a system failure or misapplication.

- Turn power off and let lamp cool before removal to avoid potential burn and electrical shock hazard during lamp replacement.
- Do not scratch glass bulb because it may break during installation or later during lamp operation.
- Lamp may only be operated in the types of fixtures prescribed in the applicable specification bulletin. Fixture lens/diffuser material must be able to contain fragments of hot quartz or glass (up to 1100°C). If in doubt, contact your fixture manufacturer.
- Screw lamp firmly but not forcibly into the socket to minimize loosening due to vibration. Do not use excessive force as the glass bulb may break.
- Electrically insulate any metal to glass support in fixture to avoid decomposition of the glass.
- Protect lamp from direct contact with liquids (such as water) to avoid breakage from thermal shock.

- In continuously operating systems (24 hours/day, 7 days/week), turn lamps off once per week for at least 15 minutes. Failure to comply increases the risk of rupture.
- Relamp fixtures at or before the end of rated life. Beyond rated life, light output diminishes while energy consumption and risk of rupture increase.

Use in Enclosed Fixtures. "Enclosed" fixture means a fixture suitably enclosed and designed to contain fragments of hot quartz or glass (up to 1100°C) per UL Standard #1572 (if in doubt, contact your fixture manufacturer).

Use In Open Fixtures. For lamps operated in the vertical position ±15° that are not designated "Enclosed Fixtures only," lamp may be used in an open or enclosed lighting fixture depending upon the application and operating environment. For example, if the lamp is located near combustible material or in an area which is unoccupied for extended periods, an enclosed fixture which can contain fragments of hot quartz or glass is recommended. For more information, contact your fixture manufacturer.

Arcstream™ tubular-shaped lamps must be used in suitably-enclosed fixtures with a UV-absorbing cover glass. Enclosed fixtures must be capable of containing fragments of hot quartz or glass (up to 1100°C), in the unusual event of the outer bulb shattering.



WARNING AND CAUTION NOTICES (Continued)

Important Notice – Metal Halide Lamps

In accordance with Federal Standard 21 CFR 1040.30, the following notice applies to Multi-Vapor®, Arcstream™ PAR64, and ConstantColor® CMH™ Lamps (those having Lamp Descriptions beginning with the letters “MVR...”, “MXR...” or “MBI150PAR64...” or “CMH...”).

“WARNING. This lamp can cause serious skin burn and eye inflammation from shortwave ultraviolet radiation if outer envelope of the lamp is broken or punctured, and the arc tube continues to operate. Do not use where people will remain for more than a few minutes unless adequate shielding or other safety precautions are used. Certain types of lamps that will automatically extinguish when the outer envelope is broken or punctured are commercially available from General Electric Company. GE self extinguishing lamps include Saf-T-Gard® Mercury and Multi-Vapor® lamps.”

HIGH PRESSURE SODIUM LAMPS

The following instructions must be complied with to help assure good lamp performance and minimize risk of breakage. General Electric Company will not be responsible for poor lamp performance, personal injury or property damage resulting from failure to follow these instructions.

- Turn power off and let lamp cool before removal to avoid potential burn and electric shock hazard during lamp replacement.
- This is a vacuum jacket lamp and may implode if broken. As a precaution, wear safety glasses and gloves when installing or removing lamp.
- Do not scratch glass bulb because it may break during installation or later during lamp operation.
- Lamp must only be operated with compatible auxiliary equipment.
- Screw lamp firmly but not forcibly into the socket to minimize loosening due to vibration. Do not use excessive force as the glass bulb may break.
- Lamp may be operated in any position.
- Electrically insulated any metal to glass support in fixture to avoid decomposition of the glass.
- Protect lamps from direct contact with liquids (such as rain, sleet or snow) to avoid breakage from thermal shock.

LOW PRESSURE SODIUM LAMPS

Before Use

1. Always isolate the equipment from the electricity supply before inserting or replacing a lamp.
2. Check that the replacement lamp is the correct type, including cap, and wattage for use in the circuit and with appropriate control gear for the application.
3. Ensure that the lamp is correctly located in the lampholder and the glass bulb is not scratched during insertion.

During Use

For all lamps (unless indicated to the contrary by the manufacturer) prevent rain, snow condensation droplets or water, splashing on the lamp as these may cause the bulb to shatter.

Disposal

Low pressure sodium lamps must be broken with precautions against the risk of fire. Precautions must also be taken against flying glass or other fragments. The lamps (not more than 20 at a time) should be broken into small pieces in a large dry container, in a dry atmosphere. The container, when one-quarter full, should be filled with water; the operator must stand back (e.g. should use a hose). After a few minutes, the metallic sodium will be inactive and the debris may be disposed of as for glass.

MERCURY LAMPS

Mercury lamps are constructed of an outer bulb with an internal arc tube made of quartz. The arc tube operates under high pressure at very high temperatures – as high as approximately 1100°C. The arc tube and outer bulb may unexpectedly rupture due to internal causes or external factors such as a system failure or misapplication.

- Turn power off and let lamp cool before removal, to avoid potential burn and electrical shock hazard during lamp replacement.
- Do not scratch glass bulb because it may break during installation or later during lamp operation.
- Lamp may be operated in any position. Lamp must only be operated with compatible electrical equipment in the types of fixtures prescribed in the applicable specification bulletin. Fixture lens/diffuser material must be able to contain fragments of hot quartz or glass (up to 1100°C). If in doubt, contact your fixture manufacturer.
- Screw lamp firmly but not forcibly into the socket to minimize loosening due to vibration. Do not use excessive force as the glass bulb may break.
- Electrically insulate any metal to glass support in fixture to avoid decomposition of the glass.
- Protect lamps from direct contact with liquids (such as rain, sleet or snow) to avoid breakage from thermal shock.
- Relamp fixtures at or before the end of rated life. Beyond rated life, light output diminishes while energy consumption and risk of rupture increase.

Important Notice – Mercury Lamps

In accordance with Federal Standard 21 CFR 1040.30, the following notice applies to all Standard Mercury Lamps (those having Lamp Descriptions beginning with the letters “H...” or “HR...”):

“WARNING: This lamp can cause serious skin burn and eye inflammation from shortwave ultraviolet radiation if outer envelope of the lamp is broken or punctured, and the arc tube continues to operate. Do not use where people will remain for more than a few minutes unless adequate shielding or other safety precautions are used. Certain types of lamps that will automatically extinguish when the outer envelope is broken or punctured are commercially available from General Electric Company. GE self-extinguishing lamps include Saf-T-Gard® mercury and Multi-Vapor® lamps.”

FOOTNOTES

Footnote

- 9 Do not use this lamp in fixtures designed for less than rated lamp wattage.
- 13 For use only in 175-watt metal halide luminaires that do not exceed maximum temperatures of 160°C at the point where metallic base meets the heat resistant collar and 245°C on the solder button of the plastic collar for this lamp.
- 14 Life shown is for vertical ±15° operation.
- 16 Approximate lumen ratings at 45° burning position: Initial - 145,000, Mean - 108,000.
- 17 Rated life based on 5 or more burning hours per start.
- 28 Use only 1000-watt H12 or H34-type ballasts. Do not use on 1000-watt H36-type ballasts.
- 30 First life rating and mean lumen rating refers to operation @ 11 hrs. on / 1 hr. off cycle. Second life rating and mean lumen rating refer to operation @ 120 hrs. on / 1 hr. off cycle.
- 31 The CMH lamps shown can be operated on listed ballasts. When the alternate ballast is used, GE recommends that a label be placed on the fixture (where it can be read by a person replacing the lamp) that states: “Designed for use with a ceramic metal halide lamp only.” A standard quartz-type metal halide lamp may not operate in the fixture.
- 32 Lamp will run at 400-watts when used on a linear reactor ballast.
- 33 Rated life based on 7 hours per start.
- 34 Approved ballast is ANSI M57 with add-on metal halide ignitor (3-4 Kv pulse, 1 micro second).
- 35 Approved ballast is ANSI M58 with add-on metal halide ignitor (3-4 Kv pulse, 1 micro second).
- 36 Approved ballasts are: ANSI M128; ANSI M59 with add-on metal halide ignitor (3-4 Kv pulse, 1 micro second); ANSI M135 with minimum open circuit voltage of 270-volts.
- 37 Approved ballasts are: ANSI M133; ANSI M48 with add-on metal halide ignitor (3-4 Kv pulse, 1 micro second).
- 38 Requires a non-ANSI designated ballast with a special, add-on metal halide ignitor. Contact your local GE Representative for a list of approved ballasts and ignitors.
- 39 UV Control is a new, quartz material that effectively cuts UVB and UVC radiation.
- 40 Approved ballasts are ANSI M135 or ANSI M59 with add-on metal halide ignitor (3-4Kv pulse, 1 micro second).

[Faint, illegible text, likely bleed-through from the reverse side of the page]





T8 LAMPS

Starcoat™ T8 Lamps	4-7
Starcoat™ XL Extra-Life Lamps	4-7
F25T12 Energy-Saving Lamps (For T8 Ballasts)	4-8
Ecolux® Lamps – TCLP Compliant	4-7
Ecolux® XL Extra-Life Lamps – TCLP Compliant	4-8
Mod-U-Line® U-Shaped Lamps	4-8
8' T8 Lamps	4-8
8' T8 High Output Lamps	4-8

T12 RAPID START LAMPS

F30T12 Lamps	4-10
F40 Ecolux® Lamps – TCLP Compliant	4-12
F40 Mod-U-Line® U-Shaped Lamps	4-12
F40 Standard Lamps	4-10
F40 Watt-Miser® Energy-Saving Lamps	4-11
F40 XL Extra-Life Lamps	4-12
F48" Utility Shoplite Lamps	4-12

SLIMLINE (Single Pin) INSTANT START LAMPS

T6, T8 and 24"-84" T12 Slimline Lamps	4-13
8' T12 Slimline Lamps	4-14
8' T12 Slimline XL Extra-Life Lamps	4-15
8' T12 Watt-Miser® Lamps	4-14
8' T12 Watt-Miser® Plus Lamps	4-14
8' T12 Ecolux® Lamps – TCLP Compliant	4-15
F40T17 Instant Start Lamps (Mogul Bipin)	4-15

T12 HIGH OUTPUT (800mA) RAPID START LAMPS 4-15

T12 VERY HIGH OUTPUT (1500mA) RAPID START LAMPS 4-17

POWER GROOVE® (1500mA) RAPID START LAMPS 4-17

PREHEAT LAMPS

T5, T8, T12 and T17 Lamps	4-9
---------------------------------	-----

GOLD LAMPS

F25T8, F32T8	4-8
F40	4-11
F72T12, F96T12	4-14
F96T12/HO	4-16

SPECIAL APPLICATION LAMPS

"All Weather" Lamps	4-18
Appliance Lamps	4-19
Blacklight/Blacklight Blue Lamps	4-20
Circline Lamps	4-19
Cov-R-Guard™ Shatter-Protected Lamps	4-17
Diazo Reprographic Lamps	4-20
Germicidal Lamps	4-20
Plant and Aquarium/Terrarium Lamps	4-19

EXPORT-ONLY LAMPS 4-21



LAMP LOCATOR (Not Drawn to Scale)

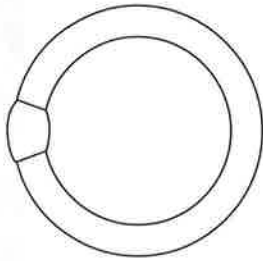

T9 Circline (1¹/₈" diameter) 4-Pin Base (G10q)

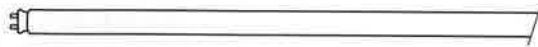

T5 (5/8" diameter) Miniature Bipin Base (G5)

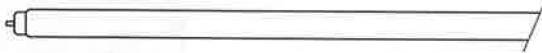

T6 (3/4" diameter) Single Pin Base (Fa8)



T8 (1" diameter) Single Pin Base (Fa8)



T8 (1" diameter) Medium Bipin Base (G13)



T8 (1" diameter) Recessed Double Contact Base (R17d)



T10 (1¹/₄" diameter) Recessed Double Contact Base (R17d)

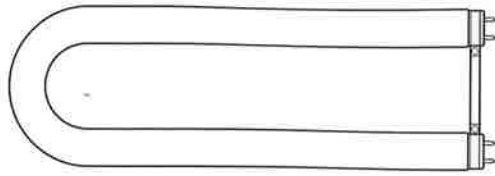

Mod-U-Line® T8/U6 (1" diameter) Medium Bipin Base (G13)

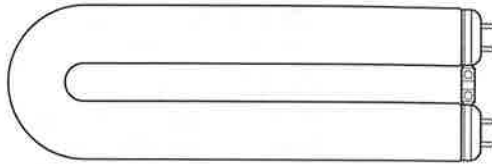

Mod-U-Line® T12/U3 (1¹/₂" diameter) Medium Bipin Base (G13)

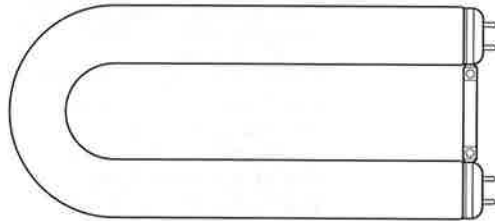

Mod-U-Line® T12/U6 (1¹/₂" diameter) Medium Bipin Base (G13)

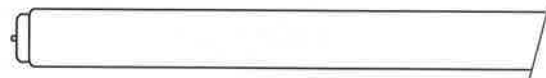

T12 (1¹/₂" diameter) Single Pin Base (Fa8)

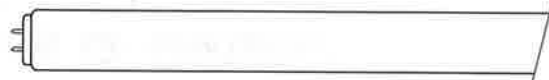

T12 (1¹/₂" diameter) Medium Bipin Base (G13)

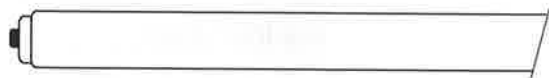

T12 (1¹/₂" diameter) Recessed Double Contact Base (R17d)

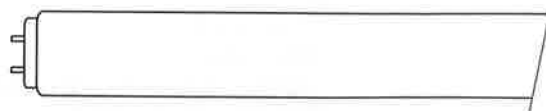

T17 (2¹/₈" diameter) Mogul Bipin (G20)

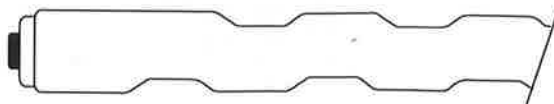

Power Groove® (2¹/₈" diameter) Recessed Double Contact Base (R17d)



BASE IDENTIFICATION



**Min Bipin
G5**

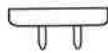

**Med Bipin
G13**



**Mog Bipin
G20**



**Single Pin
Fa8**

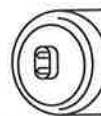

**Recessed Double
Contact
R17d**

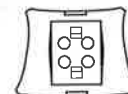

**4-Pin
G10q
(Circline)**

INTRODUCTION

GE introduced the first fluorescent lamp in 1939. Today, these lamps have become almost a universal standard in office and other lighting applications. The characteristics of fluorescent lamps vary widely according to the lamp type. In general, fluorescent lamps have the following advantages:

- **Low Operating Cost:**
Efficient, fluorescent lamps can cost significantly less to operate over their lifetime than incandescent lamps.
- **Long Life:**
Life ratings for fluorescent lamps range from 6000 to 24,000 hours based on the industry standard of 3 burning hours per start.
- **Light Quality:**
GE Starcoat™ T8 lamps offer the best color rendering and highest lumen maintenance (95%) in the industry.
- **Flexibility:**
Fluorescent lamps are available in a wide range of sizes, shapes, color performance, and wattage ratings.
- **Fast Starting:**
Rapid-Start and Instant-Start lamps typically start within 1 second of being turned on.

FLUORESCENT BRAND NAME CROSS-REFERENCE

GE	OSRAM/SYLVANIA	PHILIPS
Aquarium/Terrarium	—	—
Chroma 50	Design 50®	Colortone 50
Cov-R-Guard™	—	—
Ecolux®	Ecologic	Alto
Ecolux® XL	—	—
Gro & Sho™/Plant & Aquarium	GRO-LUX®	Agro-Lite
Kitchen and Bath ULTRA™	Interior Design® (D30)	Softone Pastel FL (SPEC 30)
Mod-U-Line®	Curvalume®	U-Bent
Power Groove®	—	—
Specification Series (SP)	Designer® Series (D)	SPEC Series
Specification Series (SPX)	Designer® "800" Series	Ultralume™
Starcoat™	—	—
T8	Octron®	TL70/TL80™
T10/1500MA	VHO/LT	—
/1500	VHO	VHO
Watt-Miser®	SuperSaver®	Econ-o-Watt
Watt-Miser® Plus	SuperSaver Plus®	—
XL	XP	Advantage

ATTENTION: This brand-name cross-reference chart is provided only as a quick reference. Other lamp company brand listings may only represent a near equivalent, versus an identical match to GE Lighting brands. Individual lamp manufacturer's performance specifications and product offerings should be consulted. Lamp performance may be affected by environmental conditions, ballast type and/or other auxiliary equipment.



PRODUCT INFORMATION

GE T8 STARCOAT™ LAMPS (pg 4-7)

- More light over life – 95% lumen maintenance
- Enhanced color rendering... best in the industry
- High system efficiency delivers significant energy cost savings
- Long lamp life... 20,000 hours, 24,000 hour XL versions

GE STARCOAT™ XL AND ECOLUX® XL EXTRA-LIFE FLUORESCENT LAMPS (pg 4-7 and 4-8)

- Longer life... up to 20% longer than standard T8 lamps... provides an extra year of quality lighting
- Best color rendering of any standard T8
- Highest lumen maintenance (95%) in industry
- Ecolux® XL lamps are TCLP compliant and may reduce disposal costs

GE ECOLUX® T8 REDUCED MERCURY LAMPS WITH STARCOAT™ (pg 4-7)

- All the superior performance benefit of Starcoat™ (best color, more light over life) in a reduced mercury lamp
- TCLP compliant, substantially lowering disposal costs where applicable (state regulations vary, consult your state EPA)
- Also available... Ecolux® 4-foot and 8-foot T12 Watt-Miser®

GE F25T12 LAMPS FOR USE WITH T8 ELECTRONIC BALLASTS (pg 4-8)

- Maximum energy cost savings in a fluorescent system
 - Less energy than T8 or T12 Watt-Miser® with minimal reduction in light output
- 25-watt energy-saving replacement for 4' T8 fluorescent lamps
- Operates on T8 electronic ballast

GE GOLD LAMPS (pg 4-8, 4-11, 4-14, and 4-16)

- Block UV emissions
- Highly efficient
- Used in photo-sensitive applications, semi-conductor assembly, darkrooms

GE T8 MOD-U-LINE® U-SHAPED FLUORESCENT LAMPS (pg 4-8)

- Primarily used in 2x2 fixtures with prismatic or parabolic lenses
- Lower energy costs... 36% energy cost saving vs. F40T12 U-Tubes
- Longer lamp life than T12 Mod-U-Line®— 20,000 hours

GE 8' T8 HIGH OUTPUT LAMPS (pg 4-8)

Cost efficient T8 lighting and long life

- High system efficiency delivers 38% cost energy savings
- 50% longer life than T12 high output lamps
- Wide choice of color options
- Operate at 400mA

GE PREHEAT FLUORESCENT LAMPS (pg 4-9 and 4-10)

- Require starters
- Available in various diameters (T5, T8, T12, and T17) and various lengths (6" to 60")
- **Smaller sizes excellent for low-profile applications, including cabinet, display case lighting, emergency lighting, and transportation vehicles**

GE FLUORESCENT T12 RAPID START LAMPS (pg 4-10 to 4-13)

- Popular for commercial lighting
- Upgrade new and existing facilities easily... change the lamp to SP/SPX color-improved lamps, available in standard and Watt-Miser® versions

GE T12 WATT-MISER® ENERGY-SAVING LAMPS (WM) (pg 4-10 and 4-11)

- Energy-saving replacement for standard T12 fluorescent lamps
- 12% to 20% savings in energy costs vs. standard fluorescent
- 83% to 89% of the light output of standard fluorescent

GE T12 MOD-U-LINE® U-SHAPED LAMPS (pg 4-12 and 4-13)

- Available in standard and Watt-Miser® versions
- Operate on standard or electronic rapid start ballasts

GE SLIMLINE LAMPS (pg 4-13)

- One of the most efficient fluorescent products available, up to 97 lumens per watt
- Single pin based lamps designed to operate on instant start ballast

GE 8' SLIMLINE WATT-MISER® PLUS (pg 4-14)

- Maximum energy savings
- Same light output as standard Slimline lamps

GE 8' SLIMLINE XL LAMPS (pg 4-15)

- Extra-life... lasts 25% longer than standard F96 lamps for reduced lamp replacement and maintenance costs
- Excellent color... color enhanced SP and SPX versions provide color so true and natural you won't believe it's fluorescent

GE HIGH OUTPUT LAMPS (pg 4-15 and 4-16)

- High light output and long life
- Produces about 45% more initial lumens than Slimline lamps of same size
- Usually operated at 800mA



PRODUCT INFORMATION (Continued)

GE VERY HIGH OUTPUT LAMPS (pg 4-17)

- Where high light levels are required – factories, warehouses, gymnasiums, open areas
- Rapid start, operate at 1500mA

GE POWER GROOVE® LAMPS (pg 4-17)

- Highest light output of any fluorescent lamp
- Grooved bulb actually increases the effective arc length by about 10%
- Rapid start, operate at 1500mA

COV-R-GUARD™ SHATTER PROTECTED FLUORESCENT LAMPS (pg 4-17 and 4-18)

- Protective shield effectively contains shattered glass particles if lamp is broken
- Protects people, food, etc. from broken glass
- Available in many types and wattages, including T12, T8 with Starcoat™ and Ecolux® lamps

GE ALL-WEATHER LAMPS (pg 4-18)

- Top performance for outdoor applications, freezers, low temperature display cases
- For severe or continued low temperatures (down to -20° F or -29° C) and/or high wind velocities use T10 or T10J (Jacketed) lamps for better light output than T12 or T12J
- In still air environments, T12 and T12J offer equal or superior lumen performance
- Rated nominal lamp watts and initial lumens are peak values. Actual watt and lumen values may be somewhat lower in service, depending on ambient conditions

GE CIRCLINE FLUORESCENT LAMPS (pg 4-19)

- Used in household, kitchen and bath applications... where significant levels of uniform light are desired
- Designed for operation on rapid start ballasts; will also operate on preheat or switch start ballasts

GE APPLIANCE LAMPS (pg 4-19)

- Designed for intermittent burning service in appliances, ovens and dryers
- Rated at 3 hrs per start; life and watts depend upon the ballast

GE BLACKLIGHT AND REPROGRAPHIC (pg 4-20)

- Blacklight (BL) lamps are commonly used in “bug zappers”
- Blacklight Blue (BLB) lamps are often used decoratively in disco lighting and theatrical applications. These lamps are made with a special dark blue glass that filters most visible light.
- The Diazo Reprographic lamp emits a blue light, peaking at approximately 417 nanometers... used primarily in reprographic equipment

GE GERMICIDAL LAMPS (pg 4-20)

- Clear lamps with special UV transmitting glass
- The 253.7 nanometer radiation from the mercury discharge is passed through the glass
- Used in water and air purification applications

GE ELECTRONIC BALLASTS

Energy efficiency and high performance make GE Electronic Ballasts and GE Fluorescent Lamps the perfect match for total performance.

- Energy efficient — GE has the most efficient system on the market to dramatically reduce electricity costs
- Broadest selection of electronic ballasts on the market
- Outstanding quality
- Industry-leading technical hotline provides specification and application support

See **GE Electronic Ballast System Catalog** (#82696) for more information. For your electromagnetic ballast needs, MagneTek magnetic ballasts are now also available from GE Lighting.





HEADINGS IN THIS CATALOG SECTION

The following terms and descriptions can help you when checking Fluorescent lamp specifications and when ordering products. Within each product line, lamps are divided into families, within these families, lamps are then listed by wattage.

Product Code:

It is important to use this five-digit code when ordering to ensure that you receive the exact product you require.

Ⓢ Means this lamp meets Federal Minimum Efficiency Standards.

Ⓡ Indicates that this is a lamp with high color rendering, which helps objects and persons illuminated to appear more true to life.

Energy Used - Nominal Watts:

Energy used (as defined by FTC Lamp Label Rules). To estimate energy consumption (kWh), multiply watts x hours of use and divide by 1000.

⚡ Indicates that this is a reduced wattage option for lamps normally used in this application. Be sure to check wattage, lumens and life to determine which lamp is best suited to your needs.

Additional Information:

Typical application and/or other important information including footnotes (†).

Lamp Description:

The lamp's identification code.

Case Quantity:

Number of product units packed in a case.

Color Rendering Index (CRI or R_a):

An indication of the ability of the lamp to render object colors in a normal, natural way. The higher the number (0-100), the better the color appearance.

Color Temperature Kelvins (K):

A measure of the visual "warmth" or "coolness" of the light from the lamp. The higher the value, the whiter or "cooler" the light appears.

Rated Average Life - Hours:

Lamp burning hours to median life expectancy.

Mean Lumens:

Lamp light output at 40% of rated lamp life.

Initial Lumens:

Lamp light output after the initial 100 hours of operation.

Nominal Length:

Lamp length including base and/or pins.

Nominal Product Watts	Product Code	Lamp Description	Case Qty.	Additional Information	Nominal Length in.	Lumens Initial	Mean Lumens	Rated Avg. Life Hours	Color Temp. K	CRI
-----------------------	--------------	------------------	-----------	------------------------	--------------------	----------------	-------------	-----------------------	---------------	-----

T8 LAMPS (Medium Bipin Unless Otherwise Noted)

STARCOAT™ T8 LAMPS

32	22656	Ⓢ Ⓡ F32T8/SPX35	36	RE 835 Phosphor, Starcoat™	48	2950	2800	20000	3500	86
----	-------	-----------------	----	----------------------------	----	------	------	-------	------	----

F 32 T8 / SPX35

Identifies as Fluorescent lamp.

Identifies either the lamp's wattage or its length in inches.

Identifies the lamp shape and the bulb diameter in eighths of an inch.

Identifies the lamp finish or color.

WHEN YOU DON'T KNOW THE LAMP DESCRIPTION

- 1 Identify bulb shape by using table on page 4-2.
- 2 Measure bulb diameter using ruler in Appendix section page A-1 to determine width in eighths of an inch.
- 3 Identify base type using table on page 4-3.
- 4 Find your lamp in the table containing the bulb shape, size and base.

WATT-MISER® ENERGY-SAVING REPLACEMENTS

Standard Lamp	40-watt F40 U Tube	40-watt F40 Rapid Start	40-watt F40 Rapid Start	75-watt F96 Slimline	110-watt F96 High Output	215-watt F96 Power Groove®	215-watt F96 1500 ma T12
Energy Saving Replacement	Replace w/ 35-watt F40 Watt-Miser® U Tube	Replace w/ 34-watt F40 Watt-Miser®	Replace w/ 32-watt F40 Watt-Miser® Plus	Replace w/ 60-watt F96 Watt-Miser®	Replace w/ 95-watt F96HO Watt-Miser®	Replace w/ 185-watt F96PG Watt-Miser®	Replace w/ 185-watt F96 1500 ma, T12 Watt-Miser®
Energy Savings*	\$7.00	\$12.00	\$16.00	\$18.00	\$18.00	\$36.00	\$27.00

* 10 ¢ per KWH over lamp life.

Fluorescent Lamps



Nominal Watts	Product Code	Lamp Description	Case Qty.	Additional Information	Nominal Length in.	Lumens Initial	Lumens Mean	Rated Avg. Life Hours	Color Temp. K	CRI
T8 LAMPS (Medium Bipin Unless Otherwise Noted)										
STARCOAT™ T8 LAMPS										
17	22642	➤ ⚡ F17T8/SPX30	24	RE 830 Phosphor, Starcoat™	24	1350	1280	20000	3000	86
	22646	➤ ⚡ F17T8/SPX35	24	RE 835 Phosphor, Starcoat™	24	1350	1280	20000	3500	86
	22647	➤ ⚡ F17T8/SPX41	24	RE 841 Phosphor, Starcoat™	24	1350	1280	20000	4100	86
	17033	➤ ⚡ F17T8/SP30	24	RE 730 Phosphor, Starcoat™	24	1325	1260	20000	3000	78
	17035	➤ ⚡ F17T8/SP35	24	RE 735 Phosphor, Starcoat™	24	1325	1260	20000	3500	78
	17036	➤ ⚡ F17T8/SP41	24	RE 741 Phosphor, Starcoat™	24	1325	1260	20000	4100	78
25	22648	➤ ⚡ F25T8/SPX30	24	RE 830 Phosphor, Starcoat™	36	2150	2040	20000	3000	86
	22650	➤ ⚡ F25T8/SPX35	24	RE 835 Phosphor, Starcoat™	36	2150	2040	20000	3500	86
	22651	➤ ⚡ F25T8/SPX41	24	RE 841 Phosphor, Starcoat™	36	2150	2040	20000	4100	86
	15943	➤ ⚡ F25T8/SP30	24	RE 730 Phosphor, Starcoat™	36	2080	1970	20000	3000	78
	15944	➤ ⚡ F25T8/SP35	24	RE 735 Phosphor, Starcoat™	36	2080	1970	20000	3500	78
	15945	➤ ⚡ F25T8/SP41	24	RE 741 Phosphor, Starcoat™	36	2080	1970	20000	4100	78
32	22655	Ⓢ ➤ ⚡ F32T8/SPX30	36	RE 830 Phosphor, Starcoat™	48	2950	2800	20000	3000	86
	22656	Ⓢ ➤ ⚡ F32T8/SPX35	36	RE 835 Phosphor, Starcoat™	48	2950	2800	20000	3500	86
	22657	Ⓢ ➤ ⚡ F32T8/SPX41	36	RE 841 Phosphor, Starcoat™	48	2950	2800	20000	4100	86
	23460	Ⓢ ➤ ⚡ F32T8/SPX50	36	RE 850 Phosphor, Starcoat™	48	2800	2660	20000	5000	86
	15946	Ⓢ ➤ ⚡ F32T8/SP30	36	RE 730 Phosphor, Starcoat™	48	2850	2710	20000	3000	78
	25396	Ⓢ ➤ ⚡ F32T8/SP30/UPC	36	RE 730 Phosphor, Starcoat™, UPC Code	48	2850	2710	20000	3000	78
	15947	Ⓢ ➤ ⚡ F32T8/SP35	36	RE 735 Phosphor, Starcoat™	48	2850	2710	20000	3500	78
	25392	Ⓢ ➤ ⚡ F32T8/SP35/UPC	36	RE 735 Phosphor, Starcoat™, UPC Code	48	2850	2710	20000	3500	78
	15949	Ⓢ ➤ ⚡ F32T8/SP41	36	RE 741 Phosphor, Starcoat™	48	2850	2710	20000	4100	78
	25394	Ⓢ ➤ ⚡ F32T8/SP41/UPC	36	RE 741 Phosphor, Starcoat™, UPC Code	48	2850	2710	20000	4100	78
	23384	Ⓢ ➤ ⚡ F32T8/SP41/C	12	RE 741 Phosphor, Starcoat™, Pro-line™ Commercial Pack	48	2850	2710	20000	4100	78
	14613	Ⓢ ➤ ⚡ F32T8/SP50	36	RE 750 Phosphor, Starcoat™	48	2750	2610	20000	5000	78
	12132	Ⓢ ➤ ⚡ F32T8/SP65	36	RE 765 Phosphor, Starcoat™	48	2700	2565	20000	6500	75
40	22660	➤ ⚡ F40T8/SPX30	24	RE 830 Phosphor	60	3725	3350	20000	3000	84
	22661	➤ ⚡ F40T8/SPX35	24	RE 835 Phosphor	60	3725	3350	20000	3500	84
	22662	➤ ⚡ F40T8/SPX41	24	RE 841 Phosphor	60	3725	3350	20000	4100	80
	15950	➤ ⚡ F40T8/SP30	24	RE 730 Phosphor	60	3600	3240	20000	3000	75
	15951	➤ ⚡ F40T8/SP35	24	RE 735 Phosphor	60	3600	3240	20000	3500	75
	15952	➤ ⚡ F40T8/SP41	24	RE 741 Phosphor	60	3600	3240	20000	4100	75
STARCOAT XL™ EXTRA-LIFE LAMPS										
32	12528	Ⓢ ➤ ⚡ F32T8/XL/SPX30	36	RE 830 Phosphor, Starcoat™ XL (7)*	48	2950	2800	24000	3000	86
	12529	Ⓢ ➤ ⚡ F32T8/XL/SPX35	36	RE 835 Phosphor, Starcoat™ XL (7)*	48	2950	2800	24000	3500	86
	12530	Ⓢ ➤ ⚡ F32T8/XL/SPX41	36	RE 841 Phosphor, Starcoat™ XL (7)*	48	2950	2800	24000	4100	86
	12539	Ⓢ ➤ ⚡ F32T8/XL/SPX50	36	RE 850 Phosphor, Starcoat™ XL (7)*	48	2800	2660	24000	5000	86
	25359	Ⓢ ➤ ⚡ F32T8/XL/SP30	36	RE 730 Phosphor, Starcoat™ XL	48	2850	2710	24000	3000	78
	25360	Ⓢ ➤ ⚡ F32T8/XL/SP35	36	RE 735 Phosphor, Starcoat™ XL	48	2850	2710	24000	3500	78
	25363	Ⓢ ➤ ⚡ F32T8/XL/SP41	36	RE 741 Phosphor, Starcoat™ XL	48	2850	2710	24000	4100	78
ECOLUX® LAMPS - TCLP COMPLIANT										
32	25611	Ⓢ ➤ ⚡ F32T8/SPX30/ECO	36	RE 830 Phosphor, Ecolux® with Starcoat™	48	2950	2800	20000	3000	86
	25612	Ⓢ ➤ ⚡ F32T8/SPX35/ECO	36	RE 835 Phosphor, Ecolux® with Starcoat™	48	2950	2800	20000	3500	86
	25613	Ⓢ ➤ ⚡ F32T8/SPX41/ECO	36	RE 841 Phosphor, Ecolux® with Starcoat™	48	2950	2800	20000	4100	86
	26666	Ⓢ ➤ ⚡ F32T8/SP30/ECO	36	RE 730 Phosphor, Ecolux® with Starcoat™	48	2850	2710	20000	3000	78
	26667	Ⓢ ➤ ⚡ F32T8/SP35/ECO	36	RE 735 Phosphor, Ecolux® with Starcoat™	48	2850	2710	20000	3500	78
	26668	Ⓢ ➤ ⚡ F32T8/SP41/ECO	36	RE 741 Phosphor, Ecolux® with Starcoat™	48	2850	2710	20000	4100	78

Ⓢ Means this lamp meets Federal Minimum Efficiency Standards.

To save energy costs, find the bulbs with the light output you need, then choose the one with the lowest watts.

(*) * All footnote references found at the end of this section. ➤ Reduced Wattage ⚡ High Color Rendering.

To convert inches to millimeters, multiply by 25.4.



Nominal Watts	Product Code	Lamp Description	Case Qty.	Additional Information	Nominal Length in.	Lumens Initial	Lumens Mean	Rated Avg. Life Hours	Color Temp. K	CRI
T8 LAMPS (Medium Bipin Unless Otherwise Noted) (Continued)										
ECOLUX® XL EXTRA-LIFE LAMPS – TCLP COMPLIANT										
32	27619	Ⓢ F32T8/XL/SPX30/ECO	36	RE 830 Phosphor, Ecolux® XL with Starcoat™	48	2950	2800	24000	3000	86
	27620	Ⓢ F32T8/XL/SPX35/ECO	36	RE 835 Phosphor, Ecolux® XL with Starcoat™	48	2950	2800	24000	3500	86
	27621	Ⓢ F32T8/XL/SPX41/ECO	36	RE 841 Phosphor, Ecolux® XL with Starcoat™	48	2950	2800	24000	4100	86
	27616	Ⓢ F32T8/XL/SP30/ECO	36	RE 730 Phosphor, Ecolux® XL with Starcoat™	48	2850	2710	24000	3000	78
	27617	Ⓢ F32T8/XL/SP35/ECO	36	RE 735 Phosphor, Ecolux® XL with Starcoat™	48	2850	2710	24000	3500	78
	27618	Ⓢ F32T8/XL/SP41/ECO	36	RE 741 Phosphor, Ecolux® XL with Starcoat™	48	2850	2710	24000	4100	78
F25T12 ENERGY-SAVING LAMPS (Use On T8 Electronic Ballasts)										
25	11439	Ⓢ F25T12/SP30	30	RE 730 Phosphor	48	2300	2140	20000	3000	70
	11440	Ⓢ F25T12/SP35	30	RE 735 Phosphor	48	2300	2140	20000	3500	73
	11442	Ⓢ F25T12/SP41	30	RE 741 Phosphor	48	2300	2140	20000	4100	72
GOLD LAMPS										
25	23008	Ⓢ F25T8/GO	24	Gold	36	1360	1140	20000	-	-
32	23009	Ⓢ F32T8/GO	36	Gold	48	1750	1470	20000	-	-
MOD-U-LINE® U-SHAPED LAMPS										
32	10483	Ⓢ F32T8/SPX30/U/6	12	RE 830 Phosphor, 6" Spacing Between Legs	22½	2800	2630	20000	3000	84
	10485	Ⓢ F32T8/SPX35/U/6	12	RE 835 Phosphor, 6" Spacing Between Legs	22½	2800	2630	20000	3500	84
	10488	Ⓢ F32T8/SPX41/U/6	12	RE 841 Phosphor, 6" Spacing Between Legs	22½	2800	2630	20000	4100	80
	10489	Ⓢ F32T8/SPX50/U/6	12	RE 850 Phosphor, 6" Spacing Between Legs	22½	2660	2510	20000	5000	80
	10479	Ⓢ F32T8/SP30/U/6	12	RE 730 Phosphor, 6" Spacing Between Legs	22½	2700	2565	20000	3000	75
	23585	Ⓢ F32T8/SP35/U/6	12	RE 735 Phosphor, 6" Spacing Between Legs	22½	2700	2565	20000	3500	75
	10480	Ⓢ F32T8/SP41/U/6	12	RE 741 Phosphor, 6" Spacing Between Legs	22½	2700	2565	20000	4100	75
8' LAMPS (Single Pin)										
59	23414	Ⓢ F96T8/SPX30	24	RE 830 Phosphor	96	5950	5440	15000	3000	84
	23415	Ⓢ F96T8/SPX35	24	RE 835 Phosphor	96	5950	5440	15000	3500	84
	23416	Ⓢ F96T8/SPX41	24	RE 841 Phosphor	96	5950	5440	15000	4100	80
	23575	Ⓢ F96T8/SPX50	24	RE 850 Phosphor	96	5650	5300	15000	5000	80
	23407	Ⓢ F96T8/SP30	24	RE 730 Phosphor	96	5800	5310	15000	3000	75
	23411	Ⓢ F96T8/SP35	24	RE 735 Phosphor	96	5800	5310	15000	3500	75
	23412	Ⓢ F96T8/SP41	24	RE 741 Phosphor	96	5800	5310	15000	4100	75
8' HIGH OUTPUT LAMPS (400mA, Recessed Double Contact Base)										
86	12532	Ⓢ F96T8/SPX30/HO	24	RE 830 Phosphor (7)*	96	8200	7380	18000	3000	84
	12533	Ⓢ F96T8/SPX35/HO	24	RE 835 Phosphor (7)*	96	8200	7380	18000	3500	84
	12534	Ⓢ F96T8/SPX41/HO	24	RE 841 Phosphor (7)*	96	8200	7380	18000	4100	80
	12535	Ⓢ F96T8/SPX50/HO	24	RE 850 Phosphor (7)*	96	8200	7380	18000	5000	80
	12536	Ⓢ F96T8/SP30/HO	24	RE 730 Phosphor (7)*	96	8000	7200	18000	3000	75
	12537	Ⓢ F96T8/SP35/HO	24	RE 735 Phosphor (7)*	96	8000	7200	18000	3500	75
	12538	Ⓢ F96T8/SP41/HO	24	RE 741 Phosphor (7)*	96	8000	7200	18000	4100	75

Ⓢ Means this lamp meets Federal Minimum Efficiency Standards.

To save energy costs, find the bulbs with the light output you need, then choose the one with the lowest watts.
 (*) * All footnote references found at the end of this section. Ⓢ Reduced Wattage Ⓢ High Color Rendering. To convert inches to millimeters, multiply by 25.4.



Nominal Watts	Product Code	Lamp Description	Case Qty.	Additional Information	Nominal Length in.	Lumens Initial	Lumens Mean	Rated Avg. Life Hours	Color Temp. K	CRI
PREHEAT LAMPS (Starter Required)										
T5 LAMPS (Miniature Bipin)										
4	10004	F4T5/CW	24	Cool White	6	135	100	6000	4100	60
	15983	F4T5/CW CARD	10	Cool White, Carded	6	135	100	6000	4100	60
6	10032	F6T5/CW	24	Cool White	9	295	235	7500	4100	60
	15986	F6T5/CW CARD	10	Cool White, Carded	9	295	235	7500	4100	60
	10028	F6T5/D	24	Daylight	9	230	185	7500	6500	75
8	10059	F8T5/CW	24	Cool White	12	400	320	7500	4100	60
	15987	F8T5/CW CARD	10	Cool White, Carded	12	400	320	7500	4100	60
	10064	F8T5/WW	24	Warm White	12	410	330	7500	3000	52
	25425	F8T5/WW CARD	10	Warm White, Carded	12	410	330	7500	3000	52
	10055	F8T5/D	24	Daylight	12	330	265	7500	6500	75
13	10086	F13T5/CW	24	Cool White	21	850	705	7500	4100	60
	10089	F13T5/WW	24	Warm White	21	870	720	7500	3000	52
	25426	F13T5/WW CARD	10	Warm White, Carded	21	870	720	7500	3000	52
T8 LAMPS (Medium Bipin)										
13	10098	F13T8/CW	24	Cool White	12	565	480	7500	4100	60
14	10104	F14T8/CW	24	Cool White	15	685	580	7500	4100	60
15	19644	F15T8/SPX30	24	RE 830 Phosphor	18	1000	900	7500	3000	82
	19645	F15T8/SPX35	24	RE 835 Phosphor	18	1000	900	7500	3500	82
	17911	F15T8/SP35	24	RE 735 Phosphor	18	940	850	7500	3500	75
	19643	F15T8/SP41	24	RE 741 Phosphor	18	940	850	7500	4100	72
	21326	F15T8/KB 6PK	24	Kitchen and Bath ULTRA™	18	940	850	7500	3000	70
	10142	F15T8/CW	24	Cool White	18	825	725	7500	4100	60
	10143	F15T8/CW 6PK	24	Cool White	18	825	725	7500	4100	60
	10147	F15T8/WW	24	Warm White	18	845	745	7500	3000	52
	10134	F15T8/D	24	Daylight	18	700	615	7500	6500	75
	13968	F15T8/SUN 6PK	24	Sunshine	18	620	525	7500	5000	90
30	16323	F30T8/SPX30	24	RE 830 Phosphor	36	2300	2140	7500	3000	82
	22747	F30T8/KB 6PK	24	Kitchen and Bath ULTRA™	36	2125	1910	7500	3000	70
	10316	F30T8/CW 6PK	24	Cool White	36	2175	1980	7500	4100	60
	10318	F30T8/WW 24PK	24	Warm White	36	2250	1980	7500	3000	52
	10310	F30T8/D 24PK	24	Daylight	36	1850	1625	7500	6500	75
T12 LAMPS (Medium Bipin)										
14	10116	F14T12/CW	24	Cool White	15	650	550	9000	4100	60
	10117	F14T12/CW 6PK	24	Cool White	15	650	550	9000	4100	60
	22979	F14T12/KB 6PK	24	Kitchen and Bath ULTRA™	15	700	650	9000	3000	70
15	10183	F15T12/CW 6PK	24	Cool White	18	760	685	9000	4100	60
	10185	F15T12/WW	24	Warm White	18	780	700	9000	3000	52
	22745	F15T12/KB 6PK	24	Kitchen and Bath ULTRA™	18	785	730	9000	3000	70

To save energy costs, find the bulbs with the light output you need, then choose the one with the lowest watts.

() * All footnote references found at the end of this section. ⚡ Reduced Wattage ⚡ High Color Rendering.

To convert inches to millimeters, multiply by 25.4.

Fluorescent Lamps



Nominal Watts	Product Code	Lamp Description	Case Qty.	Additional Information	Nominal Length in.	Lumens Initial	Lumens Mean	Rated Avg. Life Hours	Color Temp. K	CRI
PREHEAT LAMPS (Starter Required) (Continued)										
T12 LAMPS (Medium Bipin) (Continued)										
20	15109	F20T12/SPX30	24	RE 830 Phosphor	24	1300	1220	9000	3000	82
	15354	F20T12/SPX35	24	RE 835 Phosphor	24	1300	1220	9000	3500	82
	14423	F20T12/SP35	24	RE 735 Phosphor	24	1275	1200	9000	3500	73
	15353	F20T12/SP41	24	RE 741 Phosphor	24	1275	1200	9000	4100	72
	21325	F20T12/KB 6PK	24	Kitchen and Bath ULTRA™	24	1275	1200	9000	3000	70
	10213	F20T12/CW	24	Cool White	24	1200	1150	9000	4100	60
	10214	F20T12/CW 6PK	24	Cool White	24	1200	1150	9000	4100	60
	10217	F20T12/WW	24	Warm White	24	1250	1150	9000	3000	52
	25577	F20T12/WW/UPC	24	Warm White, UPC Code	24	1250	1150	9000	3000	52
	10205	F20T12/D	24	Daylight	24	1025	945	9000	6500	75
	25575	F20T12/D/UPC	24	Daylight, UPC Code	24	1025	945	9000	6500	75
	38114	F20T12/C50	24	Chroma 50	24	875	790	9000	5000	90
	14419	F20T12/SUN	24	Sunshine	24	875	790	9000	5000	90
	10231	F20T12/B 6PK	24	Blue	24	450	330	9000	-	-
	10233	F20T12/G 6PK	24	Green	24	1575	975	9000	-	-
T17 LAMPS (Mogul Bipin)										
82	43443	F90T17/CW/WM	12	Cool White, Watt-Miser® (1)*	60	5750	5060	9000	4100	60
90	10643	F90T17/CW	12	Cool White	60	6000	5280	9000	4100	60
T12 RAPID START LAMPS (Medium Bipin)										
F30T12 LAMPS										
25	14425	F30T12/SP35/RS/WM	24	RE 735 Phosphor, Watt-Miser® (1)*	36	2025	1780	18000	3500	73
	44599	F30T12/CW/RS/WM	24	Cool White, Watt-Miser® (1)*	36	1925	1640	18000	4100	60
	44600	F30T12/WW/RS/WM	24	Warm White, Watt-Miser® (1)*	36	1975	1680	18000	3000	52
30	15108	F30T12/SPX30/RS	24	RE 830 Phosphor	36	2375	2140	18000	3000	82
	15355	F30T12/SPX35/RS	24	RE 835 Phosphor	36	2375	2140	18000	3500	82
	15085	F30T12/SP35/RS	24	RE 735 Phosphor	36	2350	2120	18000	3500	73
	15267	F30T12/SP41/RS	24	RE 741 Phosphor	36	2350	2120	18000	4100	72
	10357	F30T12/CW/RS	24	Cool White	36	2200	1910	18000	4100	60
	39176	F30T12/CW/RS 6PK	24	Cool White	36	2200	1910	18000	4100	60
	10359	F30T12/WW/RS	24	Warm White	36	2275	1980	18000	3000	52
	10365	F30T12/D/RS	24	Daylight	36	1900	1650	18000	6500	75
	38115	F30T12/C50/RS	24	Chroma 50	36	1650	1350	18000	5000	90
F40T12 LAMPS										
32	14225	F40SP35/RS/WMP 30PK	30	RE 735 Phosphor, Watt-Miser® Plus (1, 7)*	48	2650	2400	20000	3500	80
	14221	F40CW/RS/WMP 30PK	30	Cool White, Watt-Miser® Plus (1, 7)*	48	2500	2200	20000	4100	70

© Means this lamp meets Federal Minimum Efficiency Standards.

To save energy costs, find the bulbs with the light output you need, then choose the one with the lowest watts.

() * All footnote references found at the end of this section. ⚡ Reduced Wattage ⦿ High Color Rendering. To convert inches to millimeters, multiply by 25.4.

Fluorescent Lamps



Nominal Watts	Product Code	Lamp Description	Case Qty.	Additional Information	Nominal Length in.	Lumens Initial	Lumens Mean	Rated Avg. Life Hours	Color Temp. K	CRI
T12 RAPID START LAMPS (Medium Bipin) (Continued)										
F40T12 LAMPS (Continued)										
34	14627	Ⓢ ⚡ F40SPX30/RS/WM	30	RE 830 Phosphor, Watt-Miser® (1)*	48	2900	2610	20000	3000	82
	14628	Ⓢ ⚡ F40SPX35/RS/WM	30	RE 835 Phosphor, Watt-Miser® (1)*	48	2900	2610	20000	3500	82
	14811	Ⓢ ⚡ F40SPX41/RS/WM	30	RE 841 Phosphor, Watt-Miser® (1)*	48	2900	2610	20000	4100	80
	23459	Ⓢ ⚡ F40SPX50/RS/WM	30	RE 850 Phosphor, Watt-Miser® (1)*	48	2700	2430	20000	5000	80
	14200	Ⓢ ⚡ F40SP30/RS/WM	30	RE 730 Phosphor, Watt-Miser® (1)*	48	2750	2475	20000	3000	70
	25401	Ⓢ ⚡ F40SP30/RS/WM/UPC	30	RE 730 Phosphor, Watt-Miser®, UPC Code (1)*	48	2750	2475	20000	3000	70
	13807	Ⓢ ⚡ F40SP35/RS/WM	30	RE 735 Phosphor, Watt-Miser® (1)*	48	2750	2475	20000	3500	73
	23486	Ⓢ ⚡ F40SP35/WM/C 10PK	10	RE 735 Phosphor, Watt-Miser®, Pro-line™ Commercial Pack (1)*	48	2750	2475	20000	3500	73
	21858	Ⓢ ⚡ F40SP35/RS/WM/UPC 6PK	24	RE 735 Phosphor, Watt-Miser®, UPC Code (1)*	48	2750	2475	20000	3500	73
	13809	Ⓢ ⚡ F40SP41/RS/WM	30	RE 741 Phosphor, Watt-Miser® (1)*	48	2750	2475	20000	4100	72
	25397	Ⓢ ⚡ F40SP41/RS/WM/UPC	30	RE 741 Phosphor, Watt-Miser®, UPC Code (1)*	48	2750	2475	20000	4100	72
	12134	Ⓢ ⚡ F40SP65/RS/WM	30	RE 765 Phosphor, Watt-Miser® (1)*	48	2650	2430	20000	6500	75
	13803	Ⓢ ⚡ F40CW/RS/WM 30PK	30	Cool White, Watt-Miser® (1)*	48	2650	2280	20000	4100	60
	25391	Ⓢ ⚡ F40CW/RS/WM/UPC	30	Cool White, Watt-Miser®, UPC Code (1)*	48	2650	2280	20000	4100	60
	23485	Ⓢ ⚡ F40CW/RS/WM/C 10PK	10	Cool White, Watt-Miser®, Pro-line™ Commercial Pack (1)*	48	2650	2280	20000	4100	60
	13822	Ⓢ ⚡ F40LW/RS/WM 30PK	30	Lite White, Watt-Miser® (1)*	48	2825	2430	20000	4200	49
	13821	Ⓢ ⚡ F40WW/RS/WM 30PK	30	Warm White, Watt-Miser® (1)*	48	2700	2320	20000	3000	52
	25398	Ⓢ ⚡ F40WW/RS/WM/UPC	30	Warm White, Watt-Miser®, UPC Code (1)*	48	2700	2320	20000	3000	52
	14655	Ⓢ ⚡ F40DX/RS/WM	30	Deluxe Daylight, Watt-Miser® (1)*	48	1950	1620	20000	6500	84
	19217	⚡ F40/C50/RS/WM	30	Chroma 50, Watt-Miser® (1)*	48	2000	1720	20000	5000	90
40	15079	Ⓢ F40SPX30 30PK	30	RE 830 Phosphor	48	3400	3090	20000	3000	82
	15083	Ⓢ F40SPX35 30PK	30	RE 835 Phosphor	48	3400	3090	20000	3500	82
	15084	Ⓢ F40SPX41 30PK	30	RE 841 Phosphor	48	3350	3050	20000	4100	80
	23457	Ⓢ F40SPX50	30	RE 850 Phosphor	48	3200	2860	20000	5000	80
	15075	Ⓢ F40SP30 30PK	30	RE 730 Phosphor	48	3250	2950	20000	3000	70
	15077	Ⓢ F40SP35 30PK	30	RE 735 Phosphor	48	3200	2910	20000	3500	73
	20463	Ⓢ F40SP35/UPC	30	RE 735 Phosphor, UPC Code	48	3200	2910	20000	3500	73
	15078	Ⓢ F40SP41 30PK	30	RE 741 Phosphor	48	3200	2910	20000	4100	72
	23382	Ⓢ F40SP41/C	10	RE 741 Phosphor, Pro-line™ Commercial Pack	48	3200	2910	20000	4100	72
	12133	Ⓢ F40SP65	30	RE 765 Phosphor	48	3050	2775	20000	6500	75
	25400	Ⓢ F40SP65/UPC	30	RE 765 Phosphor, UPC Code	48	3050	2775	20000	6500	75
	13969	Ⓢ F40D/ULTRA 6PK	24	Daylight ULTRA™, Retail Pack	48	3050	2775	20000	6500	75
	14654	Ⓢ F40DX	30	Deluxe Daylight	48	2250	1910	20000	6500	84
	27385	Ⓢ F40DX 10PK	10	Deluxe Daylight	48	2250	1910	20000	6500	84
	21323	Ⓢ F40KB 6PK	24	Kitchen and Bath ULTRA™	48	3400	3090	20000	3000	82
	40333	Ⓢ F40KB/TWIN	9	Kitchen and Bath ULTRA™, Twin Pack	48	3400	3090	20000	3000	82
	14440	Ⓢ F40/RES/SLV	30	Residential Light, Sleeved	48	3150	2860	15000	4100	72
	14433	Ⓢ F40/RES/SLV 6PK	24	Residential Light, Sleeved 6-pack	48	3150	2860	15000	4100	72
	14441	Ⓢ F40/RES/TWIN	9	Residential Light, Twin Pack	48	3150	2860	15000	4100	72
	13797	Ⓢ F40N 30PK	30	Natural	48	2100	1740	20000	3700	90
	13794	Ⓢ F40/C50 30PK	30	Chroma 50	48	2250	1870	20000	5000	90
	25399	Ⓢ F40C50/UPC	30	Chroma 50, UPC Code	48	2250	1870	20000	5000	90
	12224	Ⓢ F40/SUN 6PK	24	Sunshine	48	2250	1870	20000	5000	90
	13795	Ⓢ F40/C75 30PK	30	Chroma 75	48	1950	1680	20000	7500	92
	10535	Ⓢ F40CG 6PK	24	Cool Green	48	2850	2450	20000	-	-
	10514	Ⓢ F40B 6PK	24	Blue	48	1200	720	20000	-	-
	10517	Ⓢ F40G 6PK	24	Green	48	4000	2000	20000	-	-
	10522	Ⓢ F40GO 6PK	24	Gold	48	2150	1830	20000	-	-

Ⓢ Means this lamp meets Federal Minimum Efficiency Standards.

To save energy costs, find the bulbs with the light output you need, then choose the one with the lowest watts.

(*) All footnote references found at the end of this section. ⚡ Reduced Wattage Ⓢ High Color Rendering. To convert inches to millimeters, multiply by 25.4.



Nominal Watts	Product Code	Lamp Description	Case Qty.	Additional Information	Nominal Length in.	Lumens Initial	Lumens Mean	Rated Avg. Life Hours	Color Temp. K	CRI
T12 RAPID START LAMPS (Medium Bipin) (Continued)										
F40T12 XL EXTRA-LIFE LAMPS										
40	18331	F40XL/SPX30	30	RE 830 Phosphor, Extra-Life (7)*	48	3400	3060	24000	3000	82
	18332	F40XL/SPX35	30	RE 835 Phosphor, Extra-Life (7)*	48	3400	3060	24000	3500	82
	18333	F40XL/SPX41	30	RE 841 Phosphor, Extra-Life (7)*	48	3400	3060	24000	4100	80
	23471	F40XL/SPX50	30	RE 850 Phosphor, Extra-Life (7)*	48	3350	3050	24000	5000	80
	18337	F40XL/SP30	30	RE 730 Phosphor, Extra-Life (7)*	48	3300	2970	24000	3000	75
	18338	F40XL/SP35	30	RE 735 Phosphor, Extra-Life (7)*	48	3300	2970	24000	3500	75
	18342	F40XL/SP41	30	RE 741 Phosphor, Extra-Life (7)*	48	3300	2970	24000	4100	73
F40T12 ECOLUX® LAMPS – TCLP COMPLIANT										
34	23157	F40SPX30/RS/WM/ECO	30	RE 830 Phosphor, Watt-Miser®, Ecolux® (1)*	48	2900	2610	20000	3000	82
	23158	F40SPX35/RS/WM/ECO	30	RE 835 Phosphor, Watt-Miser®, Ecolux® (1)*	48	2900	2610	20000	3500	82
	23159	F40SPX41/RS/WM/ECO	30	RE 841 Phosphor, Watt-Miser®, Ecolux® (1)*	48	2900	2610	20000	4100	80
	23163	F40SP30/RS/WM/ECO	30	RE 730 Phosphor, Watt-Miser®, Ecolux® (1)*	48	2750	2475	20000	3000	70
	23165	F40SP35/RS/WM/ECO	30	RE 735 Phosphor, Watt-Miser®, Ecolux® (1)*	48	2750	2475	20000	3500	73
	23166	F40SP41/RS/WM/ECO	30	RE 741 Phosphor, Watt-Miser®, Ecolux® (1)*	48	2750	2475	20000	4100	72
	23010	F40CW/RS/WM/ECO	30	Cool White, Watt-Miser®, Ecolux® (1)*	48	2650	2280	20000	4100	60
F48" UTILITY SHOPLIGHT LAMPS (T12)										
25	14445	F48"/25W/UTSL/UPC	30	Utility Shoplite, UPC Code (10)*	48	1860	1675	12000	4100	60
	14450	F48"/25W/UTSL/SLV	30	Utility Shoplite, Sleeved (10)*	48	1860	1675	12000	4100	60
	14456	F48"/25W/UTSL/TWIN	9	Utility Shoplite, Twin Pack (10)*	48	1860	1675	12000	4100	60
MOD-U-LINE® U-SHAPED LAMPS										
35	12199	F40CW/U/3/WM	12	Cool White, Watt-Miser®, 3 ⁵ / ₈ " Spacing Between Legs (1)*	22 ¹ / ₂	2200	2050	14000	4100	60
	12200	F40WW/U/3/WM	12	Warm White, Watt-Miser®, 3 ⁵ / ₈ " Spacing Between Legs (1)*	22 ¹ / ₂	2300	2100	14000	3000	52
40	14814	F40SPX30/U/3	12	RE 830 Phosphor, 3 ⁵ / ₈ " Spacing Between Legs (7)*	22 ¹ / ₂	3000	2730	14000	3000	82
	14813	F40SPX35/U/3	12	RE 835 Phosphor, 3 ⁵ / ₈ " Spacing Between Legs (7)*	22 ¹ / ₂	3000	2730	14000	3500	82
	15259	F40SP30/U/3	12	RE 730 Phosphor, 3 ⁵ / ₈ " Spacing Between Legs (7)*	22 ¹ / ₂	2925	2660	14000	3000	70
	14228	F40SP35/U/3	12	RE 735 Phosphor, 3 ⁵ / ₈ " Spacing Between Legs (7)*	22 ¹ / ₂	2925	2660	14000	3500	73
	15260	F40SP41/U/3	12	RE 741 Phosphor, 3 ⁵ / ₈ " Spacing Between Legs (7)*	22 ¹ / ₂	2925	2660	14000	4100	72
	14649	F40SCW/U/3	12	Super Cool White, 3 ⁵ / ₈ " Spacing Between Legs (7)*	22 ¹ / ₂	2725	2400	14000	4100	75
	14610	F40SWW/U/3	12	Super Warm White, 3 ⁵ / ₈ " Spacing Between Legs (7)*	22 ¹ / ₂	2725	2400	14000	3000	75
35	12203	F40CW/U/6/WM	12	Cool White, Watt-Miser®, 6" Spacing Between Legs (1)*	22 ¹ / ₂	2300	2100	14000	4100	60
	14471	F40CW/U/6/WM/UPC	12	Cool White, Watt-Miser®, 6" Spacing Between Legs, UPC Code (1)*	22 ¹ / ₂	2300	2100	14000	4100	60
	23383	F40CW/U6/WM/C	6	Cool White, Watt-Miser®, 6" Spacing Between Legs, Commercial Pack (1)*	22 ¹ / ₂	2300	2100	14000	4100	60
	12207	F40WW/U/6/WM	12	Warm White, Watt-Miser®, 6" Spacing Between Legs (1)*	22 ¹ / ₂	2350	2150	14000	3000	52

© Means this lamp meets Federal Minimum Efficiency Standards.

To save energy costs, find the bulbs with the light output you need, then choose the one with the lowest watts.
 (*) * All footnote references found at the end of this section. Reduced Wattage High Color Rendering. To convert inches to millimeters, multiply by 25.4.



Nominal Watts	Product Code	Lamp Description	Case Qty.	Additional Information	Nominal Length in.	Lumens		Rated Avg. Life Hours	Color	
						Initial	Mean		Temp. K	CRI
T12 RAPID START LAMPS (Medium Bipin) (Continued)										
MOD-U-LINE® U-SHAPED LAMPS (Continued)										
40	14816	F40SPX30/U/6	12	RE 830 Phosphor, 6" Spacing Between Legs (7)*	22½	3100	2820	14000	3000	82
	14815	F40SPX35/U/6	12	RE 835 Phosphor, 6" Spacing Between Legs (7)*	22½	3100	2820	14000	3500	82
	15263	F40SP30/U/6	12	RE 730 Phosphor, 6" Spacing Between Legs (7)*	22½	3050	2780	14000	3000	70
	14227	F40SP35/U/6	12	RE 735 Phosphor, 6" Spacing Between Legs (7)*	22½	3050	2780	14000	3500	73
	22050	F40SP35/U/6/UPC	12	RE 735 Phosphor, 6" Spacing Between Legs, UPC Code (7)*	22½	3050	2780	14000	3500	73
	15265	F40SP41/U/6	12	RE 741 Phosphor, 6" Spacing Between Legs (7)*	22½	3050	2780	14000	4100	72
	14648	F40SCW/U/6	12	Super Cool White, 6" Spacing Between Legs (7)*	22½	2800	2460	14000	4100	75
	12520	F40SCW/U/6/UPC	12	Super Cool White, 6" Spacing Between Legs, UPC Code (7)*	22½	2800	2460	14000	4100	75
	25374	F40SCW/U6/UPC 6PK	6	Super Cool White, 6" Spacing Between Legs, UPC Code, 6 Pack (7)*	22½	2800	2460	14000	4100	75
	14632	F40SFW/U/6	12	Super Warm White, 6" Spacing Between Legs (7)*	22½	2800	2460	14000	3000	75
INSTANT START LAMPS (SLIMLINE, Single Pin Unless Otherwise Noted)										
T6 SLIMLINE LAMPS										
25	12221	F42T6/SP35	24	RE 735 Phosphor	42	1830	1700	7500	3500	73
	10720	F42T6/CW	24	Cool White	42	1750	1580	7500	4100	60
	10721	F42T6/WW	24	Warm White	42	1825	1640	7500	3000	52
40	12223	F64T6/SP35	24	RE 735 Phosphor	64	2930	2720	7500	3500	73
	10805	F64T6/CW	24	Cool White	64	2800	2520	7500	4100	60
	10807	F64T6/WW	24	Warm White	64	2900	2610	7500	3000	52
T8 SLIMLINE LAMPS										
35	10829	F72T8/CW	24	Cool White	72	3000	2730	7500	4100	60
	10835	F72T8/WW 6PK	6	Warm White	72	3100	2820	7500	3000	52
50	10912	F96T8/CW	24	Cool White	96	4050	3730	7500	4100	60
T12 SLIMLINE LAMPS										
20	10691	F24T12/CW	24	Cool White	24	900	1050	7500	4100	60
30	10709	F36T12/CW	24	Cool White	36	2000	1800	7500	4100	60
35	10735	F42T12/CW	24	Cool White	42	2400	2210	7500	4100	60
30	15183	F48T12/SP30/WM	24	RE 730 Phosphor, Watt-Miser® (1)*	48	2575	2420	9000	3000	70
	14319	F48T12/SP35/WM	24	RE 735 Phosphor, Watt-Miser® (1)*	48	2575	2420	9000	3500	73
	13048	F48T12/SP41/WM	24	RE 741 Phosphor, Watt-Miser® (1)*	48	2575	2420	9000	4100	72
	44967	F48T12/CW/WM	24	Cool White, Watt-Miser® (1)*	48	2475	2280	9000	4100	60
	44971	F48T12/LW/WM	24	Lite White, Watt-Miser® (1)*	48	2650	2440	9000	4200	49
40	15088	F48T12/SPX30	24	RE 830 Phosphor	48	3050	2870	9000	3000	82
	15116	F48T12/SPX35	24	RE 835 Phosphor	48	3050	2870	9000	3500	82
	15262	F48T12/SP35	24	RE 735 Phosphor	48	3000	2820	9000	3500	73
	10748	F48T12/CW	24	Cool White	48	2875	2650	9000	4100	60
	20461	F48T12/CW/UPC 6PK	24	Cool White, UPC Code	48	2875	2650	9000	4100	60
	10761	F48T12/D	24	Daylight	48	2450	2250	9000	6500	75
50	12446	F60T12/SP41	24	RE 741 Phosphor	60	3750	3520	12000	4100	72
	23073	F60T12/CW 15PK	15	Cool White	60	3600	3310	12000	4100	60
	23076	F60T12/D 15PK	15	Daylight	60	3000	2760	12000	6500	75
	23082	F64T12/CW 15PK	15	Cool White	64	3850	3540	10000	4100	60
	23085	F64T12/D 15PK	15	Daylight	64	3300	3040	10000	6500	75

Means this lamp meets Federal Minimum Efficiency Standards.
 To save energy costs, find the bulbs with the light output you need, then choose the one with the lowest watts.

* All footnote references found at the end of this section. Reduced Wattage High Color Rendering. To convert inches to millimeters, multiply by 25.4.



Nominal Watts	Product Code	Lamp Description	Case Qty.	Additional Information	Nominal Length in.	Lumens Initial	Lumens Mean	Rated Avg. Life Hours	Color Temp. K	CRI
INSTANT START LAMPS (SLIMLINE, Single Pin Unless Otherwise Noted) (Continued)										
T12 SLIMLINE LAMPS (Continued)										
55	15117	F72T12/SPX30 15PK	15	RE 830 Phosphor	72	4800	4510	12000	3000	82
	15098	F72T12/SPX35 15PK	15	RE 835 Phosphor	72	4800	4510	12000	3500	82
	15286	F72T12/SP35 15PK	15	RE 735 Phosphor	72	4700	4420	12000	3500	73
	15097	F72T12/SP41 15PK	15	RE 741 Phosphor	72	4700	4420	12000	4100	72
	13743	F72T12/CW 15PK	15	Cool White	72	4500	4140	12000	4100	60
	23385	F72T12/CW/C	10	Cool White, Pro-line™ Commercial Pack	72	4500	4140	12000	4100	60
	12525	F72T12/CW/UPC 10PK	10	Cool White, UPC Code	72	4500	4140	12000	4100	60
	13751	F72T12/WW 15PK	15	Warm White	72	4650	4280	12000	3000	52
	13748	F72T12/D 15PK	15	Daylight	72	3800	3500	12000	6500	75
	12524	F72T12/GO 10PK	10	Gold	72	3200	2840	12000	-	-
65	13764	F84T12/CW 15PK	15	Cool White	84	5300	4880	12000	4100	60
8' T12 SLIMLINE LAMPS										
58	40511	F96T12/SP35/WMP	15	RE 735 Phosphor, Watt-Miser® Plus (1)*	96	5700	5360	12000	3500	75
	41163	F96T12/SP41/WMP	15	RE 741 Phosphor, Watt-Miser® Plus (1)*	96	5700	5360	12000	4100	75
60	14629	F96T12/SPX30/WM 15PK	15	RE 830 Phosphor, Watt-Miser® (1)*	96	6000	5640	12000	3000	82
	14630	F96T12/SPX35/WM 15PK	15	RE 835 Phosphor, Watt-Miser® (1)*	96	6000	5640	12000	3500	82
	15340	F96T12/SPX41/WM 15PK	15	RE 841 Phosphor, Watt-Miser® (1)*	96	6000	5640	12000	4100	80
	14201	F96T12/SP30/WM 15PK	15	RE 730 Phosphor, Watt-Miser® (1)*	96	5700	5360	12000	3000	70
	13849	F96T12/SP35/WM 15PK	15	RE 735 Phosphor, Watt-Miser® (1)*	96	5700	5360	12000	3500	73
	21856	F96T12/SP35/WM/UPC	15	RE 735 Phosphor, Watt-Miser®, UPC Code (1)*	96	5700	5360	12000	3500	73
	11217	F96T12/SP35/WM/C 10PK	10	RE 735 Phosphor, Watt-Miser®, Pro-line™ Commercial Pack (1)*	96	5700	5360	12000	3500	73
	13758	F96T12/SP41/WM 15PK	15	RE 741 Phosphor, Watt-Miser® (1)*	96	5700	5360	12000	4100	72
	25395	F96T12/SP41/WM/UPC	15	RE 741 Phosphor, Watt-Miser®, UPC Code (1)*	96	5700	5360	12000	4100	72
	12128	F96T12/SP65/WM	15	RE 765 Phosphor, Watt-Miser® (1)*	96	5100	4800	12000	6500	75
	13729	F96T12/CW/WM 15PK	15	Cool White, Watt-Miser® (1)*	96	5500	5060	12000	4100	60
	25171	F96T12/UTCW/EE/C	10	Cool White, Energy Efficient, Pro-line™ Commercial Pack (1)*	96	5500	5060	12000	4100	60
	21713	F96T12/CW/WM/UPC 10PK	10	Cool White, Watt-Miser®, UPC Code (1)*	96	5500	5060	12000	4100	60
	17892	F96T12/CW/WM 10PK	10	Cool White, Watt-Miser® (1)*	96	5500	5060	12000	4100	60
	13742	F96T12/LW/WM 15PK	15	Lite White, Watt-Miser® (1)*	96	5800	5340	12000	4200	49
	13736	F96T12/WW/WM 15PK	15	Warm White, Watt-Miser® (1)*	96	5700	5240	12000	3000	52
	13756	F96T12/C50/WM 15PK	15	Chroma 50, Watt-Miser® (1)*	96	4000	3520	12000	5000	90
75	15110	F96T12/SPX30 15PK	15	RE 830 Phosphor	96	6800	6390	12000	3000	82
	15101	F96T12/SPX35 15PK	15	RE 835 Phosphor	96	6800	6390	12000	3500	82
	15335	F96T12/SPX41 15PK	15	RE 841 Phosphor	96	6800	6390	12000	4100	80
	23466	F96T12/SPX50	15	RE 850 Phosphor	96	6250	5880	12000	5000	80
	15357	F96T12/SP30 15PK	15	RE 730 Phosphor	96	6500	6110	12000	3000	70
	14067	F96T12/SP35 15PK	15	RE 735 Phosphor	96	6500	6110	12000	3500	73
	15358	F96T12/SP41 15PK	15	RE 741 Phosphor	96	6500	6110	12000	4100	72
	12127	F96T12/SP65	15	RE 765 Phosphor	96	6125	5760	12000	6500	75
	13970	F96T12/SP65/C	10	RE 765 Phosphor, Pro-line™ Commercial Pack	96	6125	5760	12000	6500	75
	13725	F96T12/N 15PK	15	Natural	96	4250	3740	12000	3700	90
	13752	F96T12/C50 15PK	15	Chroma 50	96	4600	4050	12000	5000	90
	25387	F96T12/C50/UPC	15	Chroma 50, UPC Code	96	4600	4050	12000	5000	90
	14652	F96T12/DX	15	Deluxe Daylight (7)*	96	4500	4050	12000	6500	84
	17897	F96T12/GO 10PK	10	Gold	96	4350	3870	12000	-	-

© Means this lamp meets Federal Minimum Efficiency Standards.

To save energy costs, find the bulbs with the light output you need, then choose the one with the lowest watts.
 (1) * All footnote references found at the end of this section. Reduced Wattage High Color Rendering. To convert inches to millimeters, multiply by 25.4.

Fluorescent Lamps



Nominal Watts	Product Code	Lamp Description	Case Qty.	Additional Information	Nominal Length in.	Lumens Initial	Lumens Mean	Rated Avg. Life Hours	Color Temp. K	CRI
INSTANT START LAMPS (SLIMLINE, Single Pin Unless Otherwise Noted) (Continued)										
8' T12 SLIMLINE XL EXTRA-LIFE LAMPS										
60	12404	⊕ → ⊕ F96T12/XL/SP30/WM	15	RE 830 Phosphor, Watt-Miser® (1)*	96	5900	5480	15000	3000	75
	12406	⊕ → ⊕ F96T12/XL/SP35/WM	15	RE 835 Phosphor, Watt-Miser® (1)*	96	5900	5480	15000	3500	75
	12408	⊕ → ⊕ F96T12/XL/SP41/WM	15	RE 841 Phosphor, Watt-Miser® (1)*	96	5900	5480	15000	4100	73
75	11662	⊕ ⊕ F96T12/XL/SPX30	15	RE 830 Phosphor	96	6900	6370	15000	3000	82
	11663	⊕ ⊕ F96T12/XL/SPX35	15	RE 835 Phosphor	96	6900	6370	15000	3500	82
	11664	⊕ ⊕ F96T12/XL/SPX41	15	RE 841 Phosphor	96	6900	6370	15000	4100	80
	11665	⊕ ⊕ F96T12/XL/SPX50	15	RE 850 Phosphor	96	6425	5930	15000	5000	80
	11659	⊕ ⊕ F96T12/XL/SP30	15	RE 730 Phosphor	96	6700	6180	15000	3000	75
	23576	⊕ ⊕ F96T12/XL/SP35	15	RE 735 Phosphor	96	6700	6180	15000	3500	75
	11661	⊕ ⊕ F96T12/XL/SP41	15	RE 741 Phosphor	96	6700	6180	15000	4100	73
8' T12 ECOLUX® SLIMLINE LAMPS – TCLP COMPLIANT										
60	27237	⊕ → ⊕ F96T12/SPX30/WM/ECO	15	RE 830 Phosphor, Watt-Miser®, Ecolux® (1)*	96	6000	5640	12000	3000	82
	27238	⊕ → ⊕ F96T12/SPX35/WM/ECO	15	RE 835 Phosphor, Watt-Miser®, Ecolux® (1)*	96	6000	5640	12000	3500	82
	27239	⊕ → ⊕ F96T12/SPX41/WM/ECO	15	RE 841 Phosphor, Watt-Miser®, Ecolux® (1)*	96	6000	5640	12000	4100	80
	27232	⊕ → ⊕ F96T12/SP30/WM/ECO	15	RE 730 Phosphor, Watt-Miser®, Ecolux® (1)*	96	5700	5360	12000	3000	70
	27233	⊕ → ⊕ F96T12/SP35/WM/ECO	15	RE 735 Phosphor, Watt-Miser®, Ecolux® (1)*	96	5700	5360	12000	3500	73
	27235	⊕ → ⊕ F96T12/SP41/WM/ECO	15	RE 741 Phosphor, Watt-Miser®, Ecolux® (1)*	96	5700	5360	12000	4100	72
	40373	⊕ → ⊕ F96T12/SP65/WM/ECO	15	RE 765 Phosphor, Watt-Miser®, Ecolux® (1)*	96	5100	4800	12000	6500	75
	27186	⊕ → ⊕ F96T12/CW/WM/ECO	15	Cool White, Watt-Miser®, Ecolux® (1)*	96	5500	5060	12000	4100	60
F40T17 INSTANT START LAMP (Mogul Bipin)										
40	10575	F40T17/CW/IS	12	Cool White (3)*	60	2850	2620	7500	4100	60
T12 HIGH OUTPUT RAPID START LAMPS (800mA, Recessed Double Contact)										
25	10204	F18T12/CW/HO	24	Cool White	18	1000	750	9000	4100	60
35	13051	⊕ F24T12/SP41/HO	24	RE 741 Phosphor	24	1700	1460	9000	4100	72
	10261	F24T12/CW/HO	24	Cool White	24	1620	1345	9000	4100	60
	10275	F24T12/D/HO	24	Daylight	24	1400	1160	9000	6500	75
40	33707	F30T12/CW/HO	24	Cool White	30	2250	1950	9000	4100	60
45	10374	F36T12/CW/HO	24	Cool White	36	2800	2440	9000	4100	60
	10380	F36T12/D/HO	24	Daylight	36	2350	2040	9000	6500	75
	10388	⊕ F36T12/SGN/HO	24	Sign White	36	2150	1830	9000	5400	82
55	10559	F42T12/CW/HO	24	Cool White	42	3400	2960	9000	4100	60
	10560	F42T12/D/HO	24	Daylight	42	2900	2520	9000	6500	75
	10562	⊕ F42T12/SGN/HO	24	Sign White	42	2600	2215	9000	5400	82
	15341	→ ⊕ F48T12/SP30/HO/WM	24	RE 730 Phosphor, Watt-Miser® (1)*	48	3850	3465	12000	3000	70
	15342	→ ⊕ F48T12/SP35/HO/WM	24	RE 735 Phosphor, Watt-Miser® (1)*	48	3850	3465	12000	3500	73
	11179	→ F48T12/LW/HO/WM	24	Lite White, Watt-Miser® (1)*	48	3900	3390	12000	4200	49
60	15114	⊕ F48T12/SPX30/HO	24	RE 830 Phosphor	48	4350	3920	12000	3000	82
	15115	⊕ F48T12/SPX35/HO	24	RE 835 Phosphor	48	4350	3920	12000	3500	82
	15359	⊕ F48T12/SP30/HO	24	RE 730 Phosphor	48	4250	3830	12000	3000	70
	15360	⊕ F48T12/SP35/HO	24	RE 735 Phosphor	48	4250	3830	12000	3500	73
	15361	⊕ F48T12/SP41/HO	24	RE 741 Phosphor	48	4250	3830	12000	4100	72
	10773	F48T12/CW/HO	24	Cool White	48	4050	3520	12000	4100	60
	27313	F48T12/CW/HO/UPC	24	Cool White, UPC Code	48	4050	3520	12000	4100	60
	10778	F48T12/D/HO	24	Daylight	48	3400	2960	12000	6500	75
	10573	⊕ F48T12/SGN/HO	24	Sign White	48	3100	2640	12000	5400	82

⊕ Means this lamp meets Federal Minimum Efficiency Standards.

To save energy costs, find the bulbs with the light output you need, then choose the one with the lowest watts.
 (1)* All footnote references found at the end of this section. → Reduced Wattage ⊕ High Color Rendering. To convert inches to millimeters, multiply by 25.4.



Nominal Watts	Product Code	Lamp Description	Case Qty.	Additional Information	Nominal Length in.	Lumens Initial	Lumens Mean	Rated Avg. Life Hours	Color Temp. K	CRI
T12 HIGH OUTPUT RAPID START LAMPS (800mA, Recessed Double Contact) (Continued)										
75	13056	F60T12/SP41/HO	24	RE 741 Phosphor	60	5350	4820	12000	4100	72
	23075	F60T12/CW/HO 15PK	15	Cool White	60	5150	4480	12000	4100	60
	23077	F60T12/D/HO 15PK	15	Daylight	60	4400	3830	12000	6500	75
	23081	F60T12/SGN/HO 15PK	15	Sign White	60	4000	3400	12000	5400	82
80	23083	F64T12/CW/HO 15PK	15	Cool White	64	5600	4870	12000	4100	60
	23087	F64T12/D/HO 15PK	15	Daylight	64	4750	4130	12000	6500	75
	23089	F64T12/SGN/HO 15PK	15	Sign White	64	4300	3660	12000	5400	82
85	15137	F72T12/SPX30/HO 15PK	15	RE 830 Phosphor	72	6800	6120	12000	3000	82
	15351	F72T12/SPX35/HO 15PK	15	RE 835 Phosphor	72	6800	6120	12000	3500	82
	15343	F72T12/SP30/HO 15PK	15	RE 730 Phosphor	72	6650	5990	12000	3000	70
	15347	F72T12/SP35/HO 15PK	15	RE 735 Phosphor	72	6650	5990	12000	3500	73
	15348	F72T12/SP41/HO 15PK	15	RE 741 Phosphor	72	6650	5990	12000	4100	72
	13697	F72T12/CW/HO 15PK	15	Cool White	72	6350	5520	12000	4100	60
	13702	F72T12/WW/HO 15PK	15	Warm White	72	6550	5700	12000	3000	52
	13699	F72T12/D/HO 15PK	15	Daylight	72	5350	4650	12000	6500	75
	12527	F72T12/N/HO 10PK	10	Natural	72	4300	3610	12000	3700	90
	13701	F72T12/SGN/HO 15PK	15	Sign White	72	4900	4170	12000	5400	82
	100	13766	F84T12/CW/HO 15PK	15	Cool White	84	7700	6700	12000	4100
13767		F84T12/D/HO 15PK	15	Daylight	84	6500	5660	12000	6500	75
13768		F84T12/SGN/HO 15PK	15	Sign White	84	6000	5100	12000	5400	82
95	15120	F96T12/SPX30/HO/WM 15PK	15	RE 830 Phosphor, Watt-Miser® (1)*	96	8500	7650	12000	3000	82
	15122	F96T12/SPX35/HO/WM 15PK	15	RE 835 Phosphor, Watt-Miser® (1)*	96	8500	7650	12000	3500	82
	23069	F96T12/SPX41/HO/WM 15PK	15	RE 841 Phosphor, Watt-Miser® (1)*	96	8500	7650	12000	4100	80
	15268	F96T12/SP30/HO/WM 15PK	15	RE 730 Phosphor, Watt-Miser® (1)*	96	8350	7520	12000	3000	70
	14069	F96T12/SP35/HO/WM 15PK	15	RE 735 Phosphor, Watt-Miser® (1)*	96	8350	7520	12000	3500	73
	13721	F96T12/SP41/HO/WM 15PK	15	RE 741 Phosphor, Watt-Miser® (1)*	96	8350	7520	12000	4100	72
	12131	F96T12/SP65/HO/WM	15	RE 765 Phosphor, Watt-Miser® (1)*	96	7700	6930	12000	6500	75
	13716	F96T12/CW/HO/WM 15PK	15	Cool White, Watt-Miser® (1)*	96	8000	6960	12000	4100	60
	21714	F96T12/CW/HO/WM/UPC 15PK	15	Cool White, Watt-Miser®, UPC Code (1)*	96	8000	6960	12000	4100	60
	13720	F96T12/LW/HO/WM 15PK	15	Lite White, Watt-Miser® (1)*	96	8500	7900	12000	4200	49
	13719	F96T12/WW/HO/WM 15PK	15	Warm White, Watt-Miser® (1)*	96	8200	7130	12000	3000	52
	110	15119	F96T12/SPX30/HO 15PK	15	RE 830 Phosphor	96	9350	8420	12000	3000
15352		F96T12/SPX35/HO 15PK	15	RE 835 Phosphor	96	9350	8420	12000	3500	82
23070		F96T12/SPX41/HO 15PK	15	RE 841 Phosphor	96	9350	8420	12000	4100	80
15362		F96T12/SP30/HO 15PK	15	RE 730 Phosphor	96	9200	8280	12000	3000	70
15363		F96T12/SP35/HO 15PK	15	RE 735 Phosphor	96	9200	8280	12000	3500	73
15364		F96T12/SP41/HO 15PK	15	RE 741 Phosphor	96	9200	8280	12000	4100	72
12130		F96T12/SP65/HO	15	RE 765 Phosphor	96	8900	8010	12000	6500	75
13709		F96T12/N/HO 15PK	15	Natural	96	6200	5210	12000	3700	90
13707		F96T12/C50/HO 15PK	15	Chroma 50	96	6750	5670	12000	5000	90
14653		F96T12/DX/HO	15	Deluxe Daylight (7)*	96	6600	5610	12000	6500	84
35505		F96T12/GO/HO 10PK	10	Gold	96	6300	5300	12000	-	-
11918		F96T12/CW/HO/CT	15	Cool White, For Cold Temperature Use (6)*	96	8900	7740	12000	4100	60
11919		F96T12/D/HO/CT	15	Daylight, For Cold Temperature Use (6)*	96	7600	6610	12000	6500	75

© Means this lamp meets Federal Minimum Efficiency Standards.

To save energy costs, find the bulbs with the light output you need, then choose the one with the lowest watts.

(1) * All footnote references found at the end of this section. ➤ Reduced Wattage ⚡ High Color Rendering. To convert inches to millimeters, multiply by 25.4.



Nominal Watts	Product Code	Lamp Description	Case Qty.	Additional Information	Nominal Length in.	Lumens Initial	Lumens Mean	Rated Avg. Life Hours	Color Temp. K	CRI
VERY HIGH OUTPUT RAPID START LAMPS (1500mA, Recessed Double Contact)										
110	10751	F48T12/CW/1500	24	Cool White (4)*	48	6200	4030	10000	4100	60
165	13760	F72T12/CW/1500 15PK	15	Cool White (4)*	72	9000	6300	10000	4100	60
185	13789	F96T12/CW/1500/WM 15PK	15	Cool White, Watt-Miser® (1, 4)*	96	12500	9380	9000	4100	60
	13790	F96T12/LW/1500/WM 15PK	15	Lite White, Watt-Miser® (1, 4)*	96	13250	9940	9000	4200	49
215	13781	F96T12/CW/1500 15PK	15	Cool White (4)*	96	13500	10125	10000	4100	60
	13785	F96T12/WW/1500 15PK	15	Warm White (4)*	96	14000	10500	10000	3000	52
	13783	F96T12/D/1500 15PK	15	Daylight (4)*	96	11500	8630	10000	6500	75
POWER GROOVE® RAPID START LAMPS (1500mA, Recessed Double Contact)										
95	47732	F48PG17/CW/WM	12	Cool White, Watt-Miser® (1, 4)*	48	5700	3990	12000	4100	60
110	10782	F48PG17/CW	12	Cool White (4)*	48	6000	4200	12000	4100	60
185	42666	F96PG17/CW/WM	8	Cool White, Watt-Miser® (1, 4)*	96	13500	10530	12000	4100	60
215	11009	F96PG17/CW	8	Cool White (4)*	96	14000	10915	10000	4100	60
	11018	F96PG17/D	8	Daylight (4)*	96	12700	9910	10000	6500	75
SPECIAL APPLICATION LAMPS										
COV-R-GUARD™ SHATTER-PROTECTED LAMPS										
T8 LAMPS (Medium Bipin)										
17	40799	F17T8/SP35/CVG	24	RE 735 Phosphor, Starcoat™, Cov-R-Guard™ (11)*	24	1285	1220	20000	3500	78
	40800	F17T8/SP41/CVG	24	RE 741 Phosphor, Starcoat™, Cov-R-Guard™ (11)*	24	1285	1220	20000	4100	78
25	40084	F25T8/SP35/CVG	24	RE 735 Phosphor, Starcoat™, Cov-R-Guard™ (11)*	36	2020	1920	20000	3500	78
	40085	F25T8/SP41/CVG	24	RE 741 Phosphor, Starcoat™, Cov-R-Guard™ (11)*	36	2020	1920	20000	4100	78
32	40091	F32T8/SPX30/CVG	36	RE 830 Phosphor, Starcoat™, Cov-R-Guard™ (11)*	48	2860	2715	20000	3000	86
	40093	F32T8/SPX35/CVG	36	RE 835 Phosphor, Starcoat™, Cov-R-Guard™ (11)*	48	2860	2715	20000	3500	86
	40089	F32T8/SPX41/CVG	36	RE 841 Phosphor, Starcoat™, Cov-R-Guard™ (11)*	48	2860	2715	20000	4100	86
	40086	F32T8/SP30/CVG	36	RE 730 Phosphor, Starcoat™, Cov-R-Guard™ (11)*	48	2765	2625	20000	3000	78
	40087	F32T8/SP35/CVG	36	RE 735 Phosphor, Starcoat™, Cov-R-Guard™ (11)*	48	2765	2625	20000	3500	78
	40088	F32T8/SP41/CVG	36	RE 741 Phosphor, Starcoat™, Cov-R-Guard™ (11)*	48	2765	2625	20000	4100	78
	40803	F32T8/SP30/ECO/CVG	36	RE 730 Phosphor, Starcoat™, Ecolux®, Cov-R-Guard™ (11)*	48	2765	2625	20000	3000	78
	40804	F32T8/SP35/ECO/CVG	36	RE 735 Phosphor, Starcoat™, Ecolux®, Cov-R-Guard™ (11)*	48	2765	2625	20000	3500	78
	40812	F32T8/SP41/ECO/CVG	36	RE 741 Phosphor, Starcoat™, Ecolux®, Cov-R-Guard™ (11)*	48	2765	2625	20000	4100	78
8' T8 LAMPS (Single Pin)										
59	40099	F96T8/SPX30/CVG	24	RE 830 Phosphor, Cov-R-Guard™ (11)*	96	5770	5275	15000	3000	84
	40105	F96T8/SPX35/CVG	24	RE 835 Phosphor, Cov-R-Guard™ (11)*	96	5770	5275	15000	3500	84
	40106	F96T8/SPX41/CVG	24	RE 841 Phosphor, Cov-R-Guard™ (11)*	96	5770	5275	15000	4100	80
	40094	F96T8/SP30/CVG	24	RE 730 Phosphor, Cov-R-Guard™ (11)*	96	5625	5150	15000	3000	75
	40095	F96T8/SP35/CVG	24	RE 735 Phosphor, Cov-R-Guard™ (11)*	96	5625	5150	15000	3500	75
	40096	F96T8/SP41/CVG	24	RE 741 Phosphor, Cov-R-Guard™ (11)*	96	5625	5150	15000	4100	75
8' T8 HIGH OUTPUT LAMPS (Recessed Double Contact)										
86	40107	F96T8/SP35/HO/CVG	24	RE 735 Phosphor, Cov-R-Guard™ (11)*	96	7760	6980	18000	3500	75
	40108	F96T8/SP41/HO/CVG	24	RE 741 Phosphor, Cov-R-Guard™ (11)*	96	7760	6980	18000	4100	75

© Means this lamp meets Federal Minimum Efficiency Standards.

To save energy costs, find the bulbs with the light output you need, then choose the one with the lowest watts.

() * All footnote references found at the end of this section. ⚡ Reduced Wattage ⚡ High Color Rendering.

To convert inches to millimeters, multiply by 25.4.



Nominal Watts	Product Code	Lamp Description	Case Qty.	Additional Information	Nominal Length in.	Lumens Initial	Lumens Mean	Rated Avg. Life Hours	Color Temp. K	CRI
SPECIAL APPLICATION LAMPS (Continued)										
COV-R-GUARD™ SHATTER-PROTECTED LAMPS (Continued)										
T12 RAPID START LAMPS (Medium Bipin)										
30	40126	F20T12/CW/RS/CVG	24	Cool White, Cov-R-Guard™ (11)*	24	2160	1880	18000	4100	60
40	40111	F40CW/CVG	30	Cool White, Cov-R-Guard™ (11)*	48	2930	2575	20000	4100	60
34	40114	F40SPX41/RS/WM/CVG	30	RE 841 Phosphor, Watt-Miser®, Cov-R-Guard™ (1, 11)*	48	2820	2535	20000	4100	80
	40112	F40SP35/RS/WM/CVG	30	RE 735 Phosphor, Watt-Miser®, Cov-R-Guard™ (1, 11)*	48	2665	2405	20000	3500	73
	40113	F40SP41/RS/WM/CVG	30	RE 741 Phosphor, Watt-Miser®, Cov-R-Guard™ (1, 11)*	48	2665	2405	20000	4100	72
	40109	F40CW/RS/WM/CVG	30	Cool White, Watt-Miser®, Cov-R-Guard™ (1, 11)*	48	2575	2210	20000	4100	60
	40805	F40CW/RS/WM/ECO/CVG	30	Cool White, Watt-Miser®, Ecolux®, Cov-R-Guard™ (1, 11)*	48	2575	2210	20000	4100	60
	40806	F40LW/RS/WM/CVG	30	Lite White, Watt-Miser®, Cov-R-Guard™ (1, 11)*	48	2735	2355	20000	4200	49
	40110	F40WW/RS/WM/CVG	30	Warm White, Watt-Miser®, Cov-R-Guard™ (1, 11)*	48	2625	2250	20000	3000	52
T12 PREHEAT LAMP (Medium Bipin)										
20	40125	F20T12/CW/CVG	24	Cool White, Cov-R-Guard™ (11)*	24	1160	1110	9000	4100	60
T12 INSTANT START LAMPS (Single Pin)										
40	40127	F48T12/CW/CVG	24	Cool White, Cov-R-Guard™ (11)*	48	2785	2565	9000	4100	60
75	40117	F96T12/CW/CVG	15	Cool White, Cov-R-Guard™ (11)*	96	5960	5485	12000	4100	60
60	40115	F96T12/CW/WM/CVG	15	Cool White, Watt-Miser®, Cov-R-Guard™ (1, 11)*	96	5335	4910	12000	4100	60
	40807	F96T12/CW/WM/ECO/CVG	15	Cool White, Watt-Miser®, Ecolux®, Cov-R-Guard™ (1, 11)*	96	5335	4910	12000	4100	60
	40124	F96T12/SP35/WM/CVG	15	RE 735 Phosphor, Watt-Miser®, Cov-R-Guard™ (1, 11)*	96	5525	5200	12000	3500	73
T12 HIGH OUTPUT LAMPS (Recessed Double Contact)										
60	40129	F48T12/CW/HO/CVG	24	Cool White, Cov-R-Guard™ (11)*	96	3930	3415	12000	4100	60
85	40811	F72T12/CW/HO/CVG	15	Cool White, Cov-R-Guard™ (11)*	72	6155	5355	12000	4100	60
95	40116	F96T12/CW/HO/WM/CVG	15	Cool White, Watt-Miser®, Cov-R-Guard™ (1, 11)*	96	7760	6750	12000	4100	60
	40118	F96T12/SP35/HO/WM/CVG	15	RE 735 Phosphor, Watt-Miser®, Cov-R-Guard™ (1, 11)*	96	8090	7295	12000	3500	73
	40123	F96T12/SP41/HO/WM/CVG	15	RE 741 Phosphor, Watt-Miser®, Cov-R-Guard™ (1, 11)*	96	8090	7295	12000	4100	72
110	40808	F96T12/CW/HO/CVG	15	Cool White, Cov-R-Guard™ (11)*	96	8630	7505	12000	4100	60
"ALL-WEATHER" 1500mA RAPID START LAMPS (Recessed Double Contact)										
T10 LAMPS										
110	10742	F48T10/CW	24	Cool White	48	6200	-	9000	4100	60
	10743	F48T10J/CW	12	Cool White, 1 ¹³ / ₁₆ " Diameter Clear Outer Jacket	48	6000	-	9000	4100	60
135	39157	F60T10/CW	24	Cool White	60	7000	-	6000	4100	60
	13002	F60T10/CW 6PK	6	Cool White	60	7000	-	6000	4100	60
	17135	F60T10/SP30	24	RE 730 Phosphor	60	8500	-	6000	3000	70
	40441	F60T10J/CW	12	Cool White, 1 ¹³ / ₁₆ " Diameter Clear Outer Jacket	60	8000	-	6000	4100	60
160	13776	F72T10/CW 15PK	15	Cool White	72	9700	-	9000	4100	60
	10858	F72T10J/CW	8	Cool White, 1 ¹³ / ₁₆ " Diameter Clear Outer Jacket	72	9600	-	9000	4100	60
205	13780	F96T10/CW 15PK	15	Cool White	96	13500	-	9000	4100	60
	10945	F96T10J/CW	8	Cool White, 1 ¹³ / ₁₆ " Diameter Clear Outer Jacket	96	13300	-	9000	4100	60
T12 LAMPS										
110	34206	F48T12/CW/1500/O	24	Cool White	48	7000	-	10000	4100	60
	41606	F48T12J/CW/1500/O	12	Cool White, 1 ¹³ / ₁₆ " Diameter Clear Outer Jacket	48	6800	-	10000	4100	60
170	13762	F72T12/CW/1500/O	15	Cool White	72	10800	-	10000	4100	60
	41612	F72T12J/CW/1500/O	8	Cool White, 1 ¹³ / ₁₆ " Diameter Clear Outer Jacket	72	10500	-	10000	4100	60
220	13788	F96T12/CW/1500/O	15	Cool White	96	14400	-	10000	4100	60
	41613	F96T12J/CW/1500/O	8	Cool White, 1 ¹³ / ₁₆ " Diameter Clear Outer Jacket	96	14000	-	10000	4100	60

© Means this lamp meets Federal Minimum Efficiency Standards.

To save energy costs, find the bulbs with the light output you need, then choose the one with the lowest watts.

() * All footnote references found at the end of this section. ⚡ Reduced Wattage ⚡ High Color Rendering.

To convert inches to millimeters, multiply by 25.4.

Fluorescent Lamps



Nominal Watts	Product Code	Lamp Description	Case Qty.	Additional Information	Nominal Length in.	Lumens Initial	Lumens Mean	Rated Avg. Life Hours	Color Temp. K	CRI
---------------	--------------	------------------	-----------	------------------------	--------------------	----------------	-------------	-----------------------	---------------	-----

SPECIAL APPLICATION LAMPS (Continued)

CIRCLINE T9 RAPID START LAMPS (Nominal Length=Diameter)

20	42732	FC6T9/CW	12	Cool White	6 1/2	800	560	12000	4100	60
22	11084	FC8T9/KB	6	Kitchen and Bath ULTRA™	8 1/4	1400	1120	12000	3000	82
	33774	FC8T9/CW	12	Cool White	8 1/4	1100	825	12000	4100	60
	11026	FC8T9/D	12	Daylight	8 1/4	925	690	12000	6500	75
32	11085	FC12T9/KB	6	Kitchen and Bath ULTRA™	12	2400	1920	12000	3000	82
	33890	FC12T9/CW	12	Cool White	12	1950	1460	12000	4100	60
	11039	FC12T9/D	12	Daylight	12	1675	1260	12000	6500	75
40	33893	FC16T9/CW	12	Cool White	16	2700	2030	12000	4100	60
	11052	FC16T9/D	12	Daylight	16	2250	1690	12000	6500	75

APPLIANCE LAMPS (Started Required)

T8 LAMPS

18	10257	F22" T8/D/4	24	Daylight	22	925	790	7500	6500	75
	17705	F24" T8/CW/4 6PK	24	Cool White	24	1225	1040	7500	4100	60
19	10702	F26" T8/CW/4	24	Cool White	26	1275	1085	7500	4100	60
	38199	F26" T8/CW/4 6PK	24	Cool White	26	1275	1085	7500	4100	60
	17704	F28" T8/CW/4 6PK	24	Cool White	28	1350	1145	7500	4100	60
	10349	F30" T8/CW/4	24	Cool White	30	1375	1170	7500	4100	60

T12 LAMPS

20	17735	F20T12/CW/26 6PK	24	Cool White	26	1175	1060	7500	4100	60
25	10281	F25T12/CW/28	24	Cool White	28	1665	1500	7500	4100	60
	10282	F25T12/CW/28 6PK	24	Cool White	28	1665	1500	7500	4100	60
	10286	F25T12/D/28	24	Daylight	28	1450	1310	7500	6500	75
21	10355	F30" T12/CW	24	Cool White	30	1350	1220	7500	4100	60
25	38201	F25T12/CW/33 6PK	24	Cool White	33	1860	1675	7500	4100	60
	10299	F25T12/D/33	24	Daylight	33	1600	1440	7500	6500	75
	10293	F25T12/WW/33	24	Warm White	33	1910	1720	7500	3000	52

PLANT AND AQUARIUM/TERRARIUM LAMPS (Medium Bipin)

T8 LAMPS

15	22907	F15T8/AR/FR6PK	24	Aquarium Lamp Freshwater	18	425	-	7500	-	77
	22910	F15T8/AR/FS6PK	24	Aquarium Lamp Fresh and Saltwater	18	675	-	7500	-	67
	22920	F15T8/AR/SA6PK	24	Aquarium Lamp Saltwater	18	210	-	7500	-	54
	49892	F15T8/PL/AQ 6PK	24	Plant & Aquarium Wide Spectrum	18	510	-	7500	-	90
	22904	F15T8/SR 6PK	24	Aquarium/Terrarium Lamp	18	620	525	7500	-	90

T12 LAMPS

20	22908	F20T12/AR/FR6PK	24	Aquarium Lamp Freshwater	24	600	-	9000	-	77
	22911	F20T12/AR/FS6PK	24	Aquarium Lamp Fresh and Saltwater	24	950	-	9000	-	67
	22922	F20T12/AR/SA6PK	24	Aquarium Lamp Saltwater	24	270	-	9000	-	54
	49891	F20T12/PL/AQ 6PK	24	Plant & Aquarium Wide Spectrum	24	750	-	9000	-	90
	22905	F20T12/SR 6PK	24	Aquarium/Terrarium Lamp	24	875	790	9000	-	90
40	22909	F40T12/AR/FR6PK	24	Aquarium Lamp Freshwater	48	1425	-	9000	-	77
	22914	F40T12/AR/FS6PK	24	Aquarium Lamp Fresh and Saltwater	48	2350	-	9000	-	67
	22923	F40T12/AR/SA6PK	24	Aquarium Lamp Saltwater	48	700	-	9000	-	54
	22906	F40T12/SR 6PK	24	Aquarium/Terrarium Lamp	48	2250	1870	20000	-	90
	49893	F40PL/AQ 6PK	24	Plant & Aquarium Wide Spectrum	48	1900	-	20000	-	90

To save energy costs, find the bulbs with the light output you need, then choose the one with the lowest watts.

() * All footnote references found at the end of this section. ➔ Reduced Wattage Ⓢ High Color Rendering. To convert inches to millimeters, multiply by 25.4.



Nominal Watts	Product Code	Lamp Description	Case Qty.	Additional Information	Nominal Length in.	Lumens Initial	Lumens Mean	Rated Avg. Life Hours	Temp. K	Color CRI
SPECIAL APPLICATION LAMPS (Continued)										
BLACKLIGHT/BLACKLIGHT BLUE LAMPS (Peak Emission 365nm)										
T5 LAMPS – STARTER REQUIRED (Miniature Bipin)										
4	10017	F4T5/BL	24	Blacklight, UVA Source	6	-	-	6000	-	-
	10019	F4T5/BLB	24	Blacklight Blue, UVA Source, Integral Dark Blue Filter	6	-	-	6000	-	-
8	10077	F8T5/BLB	24	Blacklight Blue, UVA Source, Integral Dark Blue Filter	12	-	-	7500	-	-
T8 LAMPS – STARTER REQUIRED (Medium Bipin)										
15	35884	F15T8/BL 6PK	24	Blacklight, UVA Source (8)*	18	-	-	7500	-	-
	35885	F15T8/BLB 6PK	24	Blacklight Blue, UVA Source, Integral Dark Blue Filter	18	-	-	7500	-	-
CIRCLINE T9 RAPID START LAMP										
22	25665	FC8T9/BLB	6	Blacklight Blue, UVA Source, Integral Dark Blue Filter	8 1/4	-	-	10000	-	-
T12 LAMPS (MEDIUM BIPIN)										
20	10244	F20T12/BL 6PK	24	Blacklight, UVA Source (8)*	24	-	-	9000	-	-
	34747	F20T12/BLB 6PK	24	Blacklight Blue, UVA Source, Integral Dark Blue Filter	24	-	-	9000	-	-
40	10526	F40BL 6PK	24	Blacklight, UVA Source (8)*	48	-	-	20000	-	-
	10531	F40BLB 6PK	24	Blacklight Blue, UVA Source, Integral Dark Blue Filter	48	-	-	20000	-	-
	40537	F40BL/U/3	12	Blacklight, UVA Source, Mod-U-Line® 3 5/8" Spacing Between Legs (8)*	22 1/2	-	-	12000	-	-
DIAZO REPROGRAPHIC 1500mA LAMP (Medium Bipin)										
125	39683	F59" T12/SPB	24	Reprographic, Peak emission 417 nm, 1000 Hours Useful Life; Actual Burning Hours Longer	60	-	-	1000	-	-
GERMICIDAL LAMPS (Peak Emission 254nm)										
T5 LAMP (Miniature Bipin)										
8	11077	G8T5	24	Clear, Preheat, For Use With Starters, UVC source (9)*	12	-	-	7500	-	-
T6 LAMP (Single Pin)										
65	11086	G64T6	24	Clear, Instant Start, 425mA (9)*	64	-	-	7500	-	-
T8 LAMPS (Medium Bipin)										
15	11078	G15T8	24	Clear, Preheat, For Use With Starters, UVC source (9)*	18	-	-	7500	-	-
25	11082	G25T8	24	Clear, Preheat, For Use With Starters, UVC source (9)*	18	-	-	7500	-	-
30	11080	G30T8	24	Clear, Preheat, For Use With Starters, UVC source (9)*	36	-	-	7500	-	-



Nominal Watts	Product Code	Description	Case Qty.	Additional Information	Nominal Length in. (mm)	Lumens Initial	Lumens Mean	Rated Avg. Life Hours	Color Temp. K	CRI
EXPORT-ONLY LAMPS (See restrictions on pg 4-21 under "General Information")										
34	14490	F40D/RS/WM/EX	30	Watt-Miser® (1)*	48 (1220)	2225	1910	20000	6500	75
40	14656	F40CW/EX	30	Cool White	48 (1220)	3050	2680	20000	4100	60
	14493	F40WW/EX	30	Warm White	48 (1220)	3150	2770	20000	3000	52
	14488	F40D/EX	30	Daylight	48 (1220)	2550	2240	20000	6500	75
	14496	F40CW/U/6/EX	12	Cool White, 6" Spacing Between Legs	22½ (570)	2800	2460	14000	4100	60
	14498	F40D/U/6/EX	12	Daylight, 6" Spacing Between Legs	22½ (570)	2350	2070	14000	6500	75
	14499	F40WW/U/3/EX	12	Warm White, 3⅝" Spacing Between Legs	22½ (570)	2825	2490	14000	3000	52
	14497	F40D/U/3/EX	12	Daylight, 3⅝" Spacing Between Legs	22½ (570)	2280	2020	14000	6500	75
75	12541	F96T12/CW/EX	15	Cool White	96 (2440)	6150	5660	12000	4100	60
	12543	F96T12/D/EX	15	Daylight	96 (2440)	5250	4330	12000	6500	75
110	12540	F96T12/CW/HO/EX	15	Cool White	96 (2440)	8900	7740	12000	4100	60
	12542	F96T12/D/HO/EX	15	Daylight	96 (2440)	7600	6610	12000	6500	75

To save energy costs, find the bulbs with the light output you need, then choose the one with the lowest watts.
 (*) * All footnote references found at the end of this section. Reduced Wattage High Color Rendering. To convert inches to millimeters, multiply by 25.4.



GENERAL INFORMATION

LUMENS

Nominal Initial Lumens refer to the nominal light output of the lamp after 100 hours of operation at 25° C. **Nominal Mean Lumens** refer to the nominal light output of the lamp at 40% of its rated life. Some values are based on engineering calculations derived from extrapolation of initial measured lumens.

A self-ballasted lamp is measured using its integral ballast. Lamps without an integral ballast are measured using reference ballasts.

Lumens produced by lamps operated on commercial ballasts may not be equivalent to reference ballast ratings. For lighting design calculations, refer to the ballast manufacturer's published data for the appropriate "Ballast Factor".

NOMINAL WATTS

Wattage is classified in accordance with American National Standards Institute standards and may not be the same as the wattage run on a reference ballast. The nominal wattage as defined by ANSI may vary from the listed wattage. Watts consumed by lamps operated on commercial ballasts may not be equivalent to reference ballast ratings. The watts shown for self ballasted lamps are nominal system watts.

OPERATING NOTES

GENERAL OPERATION

GE fluorescent lamps should be used only with auxiliary equipment designed to produce proper characteristics. Specifications for auxiliary equipment are covered by ANSI. Specifications for auxiliary equipment not included in ANSI Standards are available from GE Lighting.

FACTORS AFFECTING LAMP PERFORMANCE

Ballasts

The three basic types of ballasts for fluorescent lamps are Preheat (PH), Instant Start (IS), and Rapid Start (RS). In general, lamps identified as preheat, rapid start or instant start should be used only on the corresponding ballast type. Electronic ballasts are presently available in both instant start and rapid start designs. Ballasts that operate with output currents below recommended levels, either by design or poor performance, will reduce fluorescent lamp life.

Operating Characteristics - Fluorescent lamp life is strongly affected by the ballast. ANSI has set standards for fluorescent ballasts that will ensure proper operation of fluorescent lamps. Ballast characteristics that have a significant effect on lamp life are Current Crest Factor, Starting Time, Cathode Voltage and Open Circuit Voltage.

Ballast Factor - This is the percentage of a lamp's rated lumen output that can be expected when operated on a specific, commercially available ballast. For example, a ballast having a ballast factor of 0.93 will result in the lamp emitting 93% of its rated lumen output.

RATED AVERAGE LIFE

The rated life (hours) is the approximate median life when lamps are operated for three hours per start under laboratory conditions using ballasts which meet industry standards or GE Lighting specifications where no industry standards exist. Rated life for self-ballasted lamps is the approximate median life when operated for three hours per start under laboratory conditions. Some lamps are rated at 12 hours per start where noted.

Performance Notes:

T8 Lamps: Rated life for F17T8, F25T8, F32T8 and F40T8 lamps is rated average life on rapid start circuits. Rated average life on instant start electronic circuits is 15,000 hours.

T12 Lamps: Life of 4' T12 lamps on single-lamp, rapid start ballasts may be reduced.

COLOR TEMPERATURE / CHROMATICITY

Approximate color temperature of fluorescent is measured using industry standard methods and is based on a nominal 40-watt source. Fluorescent sources operating at different lamp currents will have slightly shifted color appearances when compared to the corresponding 40-watt sources.

High Frequency - All fluorescent lamps operate more efficiently when driven at frequencies greater than 15 kHz. Four-foot fluorescent lamps operate approximately 10% more efficiently, while eight-foot lamps improve efficiency by about 5%. This efficiency improvement is one reason for the popularity of electronic ballasts.

Temperature

Light output and watts of a fluorescent lamp are affected by the ambient temperature, and by drafts. Most fluorescent lamps reach their maximum light output at room temperatures or at "luminaire temperatures." All-Weather fluorescent lamps are designed with jackets that improve performance in low temperature environments.

Luminaire

The design of the lighting fixture (luminaire) affects the ambient temperature in which the fluorescent lamps will be operating. A fixture that operates too cool or warm will result in lower light output from the lamps and reduce illumination levels.

Starting

The life of a fluorescent lamp is affected by the number of times the lamp is started. Starting results in shorter lamp life, while continuous operation will provide the longest lamp life. All fluorescent lamps, except where noted, have life ratings based on 3 hours per start.



WARNING AND CAUTION NOTICES

CAUTION NOTICES – ALL FLUORESCENT LAMPS

Caution:

- Turn power off and let lamp cool before removal to avoid potential burn and electrical shock hazard during lamp replacement.
- Handle and install with care. Fluorescent tubes may shatter with considerable force if broken. Store in safe place away from people.

CAUTION NOTICES – GENERAL APPLICATION

Caution:

- Do not use lamps in fixtures with worn sockets. Socket may not provide adequate support and lamp may fall.
- The use of add-on shatter containing sleeves on T8 and smaller diameter products using high frequency electronic ballasts is not recommended due to increased risk of sleeve failure at end of life. GE Cov-R-Guard™ products are designed to eliminate this risk.

CAUTION NOTICES – GERMICIDAL AND BLACKLIGHT LAMPS

Caution notices are provided in accordance with ANSI/IESNA RP-27.3-96 Recommended Practice for Photobiological Safety for Lamps - Risk Group Classification & Labeling. See specific products for footnoted caution notices below (8 and 9).

CAUTION NOTICE – MOD-U-LINE® U-SHAPED LAMPS

CAUTION: Spacing bracket is not a handle. Bracket may separate from lamp.

FOOTNOTES

Footnote

- 1 Watt-Miser®, Watt-Miser® Plus and Energy Efficient (EE) lamps are intended for use where ambient temperatures are 60° F (16° C) or higher and where the lamp surface is protected from strong air drafts. Failure to protect the lamp surface may result in reduced life, poor starting or erratic operation, such as flickering or spiraling. All Watt-Miser® lamps are intended for use on two-lamp, indoor, lead, high power factor ballasts and are not recommended for use with dimming or reduced current systems. The use of Watt-Miser® lamps on single lamp ballasts may shorten lamp life. Rapid Start Watt-Miser® lamps are intended for use only with rapid start ballasts. F40 Rapid Start Watt-Miser® lamps on high frequency electronic systems may display erratic starting before end of life.
- 3 F40T12/CW/IS and F40T17/CW/IS lamps are for use only in fixtures equipped with instant start ballasts.
- 4 Because Power Groove® and Very High Output lamps are most used in commercial applications, the life rating is based on 12 hrs. per start.
- 6 Cold Temperature lamps are designed for use where ambient temperatures drop below 60 F (16 C).
- 7 Performance data based on engineering estimates.
- 8 **CAUTION:** Risk Group 1 (Low Risk): UV emitted from this lamp. Skin or eye irritation could result. Minimize exposure.
- 9 **WARNING:** Risk Group 3 (High Risk): UV emitted from this lamp. Avoid exposure of eyes and skin to unshielded lamp. Skin or eye injury will result.
- 10 Shoplites are not recommended to be used on F40 full light output ballasts. Life will be reduced by approximately 50%.
- 11 Cov-R-Guard™ light output is typically 3% less than the standard unguarded lamp.

1998

1999

2000

2001

2002

2003





PLUG-IN LAMPS

2D® 2-Pin	5-5
2D® 4-Pin	5-5
Double Biax® 2-Pin	5-6
Double Biax® 4-Pin	5-7
High Lumen Biax® Preheat	5-5
High Lumen Biax® Rapid Start/Instant Start/Preheat	5-6
Low Watt Biax®	5-5
Quad Biax® 4-Pin Base	5-8
Triple Biax® 4-Pin	5-7
Triple Biax® Inverted Base	5-8

SELF BALLASTED LAMPS

Electromagnetic Ballasted	5-9
Electronic Ballasted	5-8
Genura™	5-8

PLUG-IN LAMPS WITH SEPARABLE ELECTROMAGNETIC ADAPTERS

2D®	5-10
Biax®	5-9
Triple Biax®	5-10

ACCESSORIES

Biax® Screw-In Adapters	5-11
CFL Reflector Lenses	5-11
Locking Device	5-11

MISCELLANEOUS

Bright Stik® Lighting Unit	5-11
----------------------------------	------



BULB IDENTIFICATION

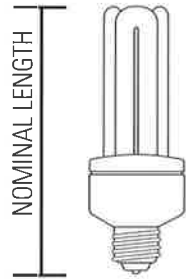

NOMINAL LENGTH:

Overall length including base or pins.

Note: Lamp drawings are not drawn to scale.
Be sure to check size and dimension information when identifying each lamp.

To convert inches to millimeters, multiply the dimension (in inches) by 25.4 (i.e. 1.5" x 25.4 = 38.1 mm).

BASE IDENTIFICATION

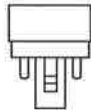

G23-2
(DBX2P)

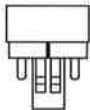

GX23-2
(DBX2P)

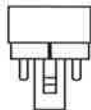

G24d-1
(DBX2P)

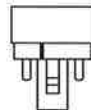

G24d-2
(DBX2P)

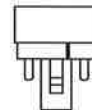

G24d-3
(DBX2P)



2G11-4
(HLBX)



E26
Med Screw

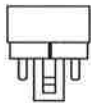

G24q-1
(DBX4P)

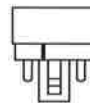

G24q-2
(DBX4P)

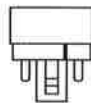

G24q-3
(DBX4P)

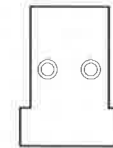

GR8-2
(2D2P)

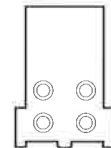

GR10q-3
(2D4P)

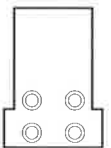

GR10q-4
(2D4P)

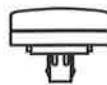
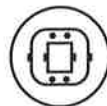

GX24q-1
(TBX4P)

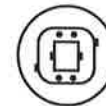

GX24q-2
(TBX4P)



GX24q-3
(TBX4P)



GX24q-4
(TBX4P)



G23
(LWBX)



GX23
(LWBX)



INTRODUCTION

GE Compact Fluorescent Lamps offer many advantages:

- Dramatic energy cost savings... up to 75% vs. incandescent lamps of comparable light output
- Extra long life... up to 13 times longer than standard incandescent lamps
- High light output comparable, and in some cases exceeding, incandescent lamps replaced
- Excellent color rendering... rare earth tri-phosphor provides color so true and natural you won't believe it's fluorescent. Deluxe SPX colors are available. Most types offer a choice of color options, from warm to cool, to let you select the tone and atmosphere you need.
- A choice of wattages, shapes and sizes to meet your lighting needs. Designed to fit everything from table lamps to wall sconces and ceiling fixtures.
- Several lamps use amalgam technology which provides stable lumen performance when operated in any position, indoors or out

COMPACT FLUORESCENT BRAND NAME CROSS-REFERENCE

GE	OSRAM/SYLVANIA	PHILIPS
2D®	—	—
Biax®	Dulux® S	PL-S
Double Biax®	Dulux® D, D/E	PL-C
Genura™	—	—
High Lumen Biax®	Dulux® L	PL-L
Quad Biax®	—	—
Triple Biax®	Dulux® T/E	PL-T

ATTENTION: This brand-name cross-reference chart is provided only as a quick reference. Other lamp company brand listings may only represent a near equivalent, versus an identical match to GE Lighting brands. Individual lamp manufacturer's performance specifications should be consulted. Lamp performance may be affected by environmental conditions, ballast type and/or other auxiliary equipment.

PRODUCT INFORMATION

GE PLUG-IN COMPACT FLUORESCENT LAMPS

- Create attractive, cost-efficient lighting designs in recessed downlights, task lights, accent lighting, or general lighting or wherever long life, compact size and energy savings are important
- High efficiency, compact size and long life
- An economical alternative to incandescent and even conventional fluorescent lighting

GE 2D® Plug-In Lamps (pg 5-5)

- GE's highest light output compact fluorescent lamp
- Uniform light distribution
- High light output – up to 200W incandescent equivalent
- Unique shape suitable for broad range of applications

GE Low-Wattage Biax® Plug-In Lamps (pg 5-5)

- Compact size offers fixture and design flexibility
- GX23 and G23 bases are preheat lamps with internal starters
- Available in warm and cool color temperatures

GE High Lumen Biax® Plug-In Lamps (pg 5-5 and 5-6)

- Available in a range of sizes and wattages for innovative compact luminaires
- High efficiency and outstanding performance in fixtures make them ideal for 2X2, 1X1 and indirect fixtures
- Available in warm to cool color temperatures; excellent color rendering

GE Double Biax® Plug-In Lamps (pg 5-6 and 5-7)

- More compact than low wattage Biax® with higher lumen output – suitable for a broad range of applications
- 2-pin: preheat lamps with starters; not suitable for use with dimming ballasts
- 4-pin: dimmable and compatible with electronic ballasts
- Available in warm to cool color temperatures

GE Triple and Quad Biax® Plug-In Lamps (pg 5-7 and 5-8)

- GE's shortest, most compact Biax® lamp. 17-31% shorter than Double Biax® lamps.
- 2-pin: preheat lamps with starters; not suitable for use with dimming ballasts
- 4-pin: dimmable and compatible with electronic ballasts
- Available in warm to cool color temperatures

ONE PIECE SELF BALLASTED LAMPS FOR INCANDESCENT SOCKETS (pg 5-8 and 5-9)

- Highly efficient – up to 75% energy cost savings vs. incandescent lamps
- Short and lightweight to meet application needs
- One piece unit screws directly into incandescent sockets and is simply discarded at end of a long life
- Wide variety of wattages and sizes to meet application needs. High and low power factor versions available.
- Genura™ reflector lamps provide more light than 75W incandescent lamps and provide the longest life of any compact fluorescent lamp

GE PLUG-IN LAMP WITH ADAPTER SYSTEMS (pg 5-9 and 5-10)

- Most economical system
- Lamp and adapter are separate. Replacable lamps plug into adapters that screw into standard incandescent sockets.
- Lamps last 10,000 hours; adapters last 40,000 hours (4 lamp lives)
- 2D® system is GE's highest light output compact fluorescent lamp: 39W system gives nearly the light of a 150W, 22W system gives more light than a 75W incandescent lamp



HEADINGS IN THIS CATALOG SECTION

The following terms and descriptions can help you when checking Compact Fluorescent lamp specifications and when ordering products. Within each product line, lamps are divided into families, within these families, lamps are then listed by wattage.

Total Harmonic Distortion (THD):

A measure (in percent) of power quality. Indicates the distortion of the alternating current wave form. Low values (<20%) are preferred.

Power Factor (PF):

A measure of power quality. The ratio of total watts to total volt-amperes. A value of 1.0 is ideal.

Minimum Starting Temperature:

The minimum ambient temperature at which the lamp will start reliably.

Color Rendering Index (CRI or R_a):

An indication of the ability of the lamp to render object colors in a normal, natural way. The higher the number (0-100), the better the color appearance.

Color Temperature - Kelvins (K):

A measure of the visual "warmth" or "coolness" of the light from the lamp. The higher the value, the whiter or "cooler" the light appears.

Rated Average Life - Hours:

Life (as defined by FTC Lamp Label Rules) is rated average life in hours.

Light Output - Mean Lumens:

Lamp light output (lumens) at 40% of rated lamp life.

Light Output - Initial Lumens:

Light output (as defined by FTC Lamp Label Rules) is rated average lumens.

Nominal Length:

Lamp length including base and/or pins.

Energy Used - Nominal Watts:

Energy Used (as defined by FTC lamp label rules). To estimate energy consumption (kWh), multiply watts x hours of use and divide by 1000.

Product Code:

It is important to use this five-digit code when ordering to ensure that you receive the exact product you require.

Lamp Description:

The lamp's identification code.

Additional Information:

Typical application and/or other important information including footnotes (†).

Case Quantity:

Number of product units packed in a case.

Base:

The type of base.

Watts	Base	Product Code	Lamp Description	Case Qty.	Additional Information	Nominal Length in.	Lumens Initial	Lumens Mean	Rated Avg. Life Hours	Color Temp K	CRI	Min. Start Temp (°C)	Power Factor	THD
15	Med	12544	FLE15TBX/L/SPX27	6	RE 827 Phosphor, Soft White, Triple Biax®, Slimshell Ballast (1, 9, 11, 12, 15)*	5.2	900	765	10000	2700	82	-10F (-23)	<.6	170%

FL E 15 TBX / L / SPX27

Identifies as Fluorescent lamp.

Electronically ballasted.

Identifies the lamp's wattage.

Identifies the lamp shape.

Identifies the lamp's ballast shape.

Identifies the lamp's finish or color.

WHEN YOU DON'T KNOW THE LAMP DESCRIPTION

1. Identify bulb shape next to lamp information.
2. Measure bulb diameter using ruler in appendix section page A-1 to determine width in eighths of an inch.
3. Identify base type using table on page 5-2.
4. Find your lamp in the table containing the bulb shape, size and base.

Compact Fluorescent Lamps



Watts	Base	Product Code	Lamp Description	Case Qty.	Additional Information	Nominal Length in.	Lumens Initial	Lumens Mean	Rated Avg. Life Hours	Color Temp K	CRI	Min. Start Temp (°C)	Power Factor	THD
-------	------	--------------	------------------	-----------	------------------------	--------------------	----------------	-------------	-----------------------	--------------	-----	----------------------	--------------	-----

2D® PLUG-IN LAMPS

2-PIN

	16 GR8-2	21302	F162D/827	50	RE 827 Phosphor (1, 2, 4)*	5.5	1050	880	8000	2700	82	25F	(-4)	
		22175	F162D/835	50	RE 835 Phosphor (1, 2, 4)*	5.5	1050	880	8000	3500	82	25F	(-4)	
	28 GR8-2	21304	F282D/827	20	RE 827 Phosphor (1, 2, 4)*	8.1	2050	1720	10000	2700	82	25F	(-4)	
		22179	F282D/835	20	RE 835 Phosphor (1, 2, 4)*	8.1	2050	1720	10000	3500	82	25F	(-4)	

4-PIN

	10 GR10q-4	21301	F102D/827/4P	60	RE 827 Phosphor (1, 2, 4, 8)*	3.6	650	545	10000	2700	82	25F	(-4)	
		22173	F102D/835/4P	60	RE 835 Phosphor (1, 2, 4, 8)*	3.6	650	545	10000	3500	82	25F	(-4)	
	16 GR10q-4	22169	F162D/827/4P	50	RE 827 Phosphor (1, 2, 4, 8)*	5.5	1050	880	8000	2700	82	25F	(-4)	
		22177	F162D/835/4P	50	RE 835 Phosphor (1, 2, 4, 8)*	5.5	1050	880	8000	3500	82	25F	(-4)	
	21 GR10q-4	21303	F212D/827/4P	50	RE 827 Phosphor (1, 2, 4, 8)*	5.5	1350	1135	10000	2700	82	25F	(-4)	
		22178	F212D/835/4P	50	RE 835 Phosphor (1, 2, 4, 8)*	5.5	1350	1135	10000	3500	82	25F	(-4)	
	28 GR10q-4	22172	F282D/827/4P	20	RE 827 Phosphor (1, 2, 4, 8)*	8.1	2050	1720	10000	2700	82	25F	(-4)	
		22180	F282D/835/4P	20	RE 835 Phosphor (1, 2, 4, 8)*	8.1	2050	1720	10000	3500	82	25F	(-4)	
	38 GR10q-4	21305	F382D/827/4P	20	RE 827 Phosphor (1, 2, 4, 8)*	8.1	2850	2395	10000	2700	82	25F	(-4)	
		25427	F382D/827/4P/CD	5	RE 827 Phosphor, Carded (1, 2, 4, 8)*	8.1	2850	2395	10000	2700	82	14F	(-10)	
		22181	F382D/835/4P	20	RE 835 Phosphor (1, 2, 4, 8)*	8.1	2850	2395	10000	3500	82	14F	(-10)	
	55 GRY10q-3	35971	F552D/827/A/4P/BULK	48	RE 827 Phosphor, Bulk Pack (1, 2, 4, 8)*	8.1	3900	3300	10000	2700	82	14F	(-10)	
		36358	F552D/830/A/T/4P/B	20	RE 830 Phosphor, Torchiere Replacement Lamp (1, 2, 4, 8)*	8.1	4000	3400	10000	3000	82	14F	(-10)	
		35972	F552D/835/A/4P/BULK	48	RE 835 Phosphor, Bulk Pack (1, 2, 4, 8)*	8.1	3900	3300	10000	3500	82	14F	(-10)	

LOW WATT BIAX® PLUG-IN LAMPS - T4

	5 G23	37654	F5BX/SPX27/827 10PK	100	RE 827 Phosphor (1, 2)*	4.2	250	210	10000	2700	82	0F	(-18)	
		13575	F5BX/SPX27/CD	6	RE 827 Phosphor, Carded (1, 2)*	4.2	250	210	10000	2700	82	0F	(-18)	
		37661	F5BX/SPX41/840 10PK	100	RE 835 Phosphor (1, 2)*	4.2	250	210	10000	4100	82	0F	(-18)	
	7 G23	37846	F7BX/SPX27/827 10PK	100	RE 827 Phosphor (1, 2)*	5.3	400	330	10000	2700	82	0F	(-18)	
		13576	F7BX/SPX27/CD	6	RE 827 Phosphor, Carded (1, 2)*	5.3	400	330	10000	2700	82	0F	(-18)	
		37659	F7BX/SPX35/835 10PK	100	RE 835 Phosphor (1, 2)*	5.3	400	330	10000	3500	82	0F	(-18)	
	9 G23	37660	F7BX/SPX41/840 10PK	100	RE 841 Phosphor (1, 2)*	5.3	400	330	10000	4100	82	0F	(-18)	
		37651	F9BX/SPX27/827 10PK	100	RE 827 Phosphor (1, 2)*	6.6	600	500	10000	2700	82	25F	(-4)	
		13577	F9BX/SPX27/CD	6	RE 827 Phosphor, Carded (1, 2)*	6.6	600	500	10000	2700	82	25F	(-4)	
	13 GX23	37652	F9BX/SPX35/835 10PK	100	RE 835 Phosphor (1, 2)*	6.6	600	500	10000	3500	82	25F	(-4)	
		37653	F9BX/SPX41/840 10PK	100	RE 841 Phosphor (1, 2)*	6.6	600	500	10000	4100	82	25F	(-4)	
		14650	F13BX/SPX27/827 10PK	100	RE 827 Phosphor (1, 2)*	7.3	825	710	10000	2700	82	32F	(0)	
		14583	F13BX/SPX27/CD	6	RE 827 Phosphor, Carded (1, 2)*	7.3	825	710	10000	2700	82	32F	(0)	
		17612	F13BX/SPX30/830 10PK	100	RE 830 Phosphor (1, 2)*	7.3	825	710	10000	3000	82	32F	(0)	
		17048	F13BX/SPX35/835 10PK	100	RE 835 Phosphor (1, 2)*	7.3	825	710	10000	3500	82	32F	(0)	
		20434	F13BX/SPX41/840 10PK	100	RE 841 Phosphor (1, 2)*	7.3	825	710	10000	4100	82	32F	(0)	
		11671	F13BX/SPX50	100	RE 850 Phosphor (1, 2)*	7.3	784	675	10000	5000	80	32F	(0)	

HIGH LUMEN BIAX® PLUG-IN LAMPS - T5

PREHEAT

	18 2G11	16649	F18BX/SPX30 10PK	40	RE 830 Phosphor (1, 2, 5, 8)*	9.0	1200	1080	10000	3000	82	25F	(-4)	
		16053	F18BX/SPX35 10PK	40	RE 835 Phosphor (1, 2, 5, 8)*	9.0	1200	1080	10000	3500	82	25F	(-4)	
		16940	F18BX/SPX41 10PK	40	RE 841 Phosphor (1, 2, 5, 8)*	9.0	1200	1080	10000	4100	82	25F	(-4)	

To save energy costs, find the bulbs with the light output you need, then choose the one with the lowest watts.
 (*) * All footnote references found at the end of this section. Reduced Wattage High Color Rendering. To convert inches to millimeters, multiply by 25.4.

Compact Fluorescent Lamps



Watts	Base	Product Code	Lamp Description	Case Qty.	Additional Information	Nominal Length in.	Lumens		Rated Avg. Life Hours	Color Temp		Min. Start Temp F	Start Temp (°C)	Power Factor	THD
							Initial	Mean		K	CRI				
HIGH LUMEN BIAX® PLUG-IN LAMPS - T5 (Continued)															
RAPID START/INSTANT START/PREHEAT															
18	2G11	17174	F18BX/SPX30/RS 10PK	40	RE 830 Phosphor (1, 2, 5, 8)*	10.5	1250	1130	20000	3000	82	50F	(10)		
		17175	F18BX/SPX35/RS 10PK	40	RE 835 Phosphor (1, 2, 5, 8)*	10.5	1250	1130	20000	3500	82	50F	(10)		
		17176	F18BX/SPX41/RS 10PK	40	RE 841 Phosphor (1, 2, 5, 8)*	10.5	1250	1130	20000	4100	82	50F	(10)		
		12521	F18BX/SPX65/RS	40	RE 865 Phosphor (1, 2, 5, 8)*	10.5	1250	1130	20000	6500	82	50F	(10)		
27	2G11	16944	F27/24BX/SPX30 10PK	40	RE 830 Phosphor (1, 2, 5, 8)*	12.8	1800	1620	12000	3000	82	50F	(10)		
		16948	F27/24BX/SPX35 10PK	40	RE 835 Phosphor (1, 2, 5, 8)*	12.8	1800	1620	12000	3500	82	50F	(10)		
		16951	F27/24BX/SPX41 10PK	40	RE 841 Phosphor (1, 2, 5, 8)*	12.8	1800	1620	12000	4100	82	50F	(10)		
39	2G11	16538	F39/36BX/SPX30 10PK	40	RE 830 Phosphor (1, 2, 5, 8)*	16.5	2850	2510	12000	3000	82	50F	(10)		
		15867	F39/36BX/SPX35 10PK	40	RE 835 Phosphor (1, 2, 5, 8)*	16.5	2850	2510	12000	3500	82	50F	(10)		
		16952	F39/36BX/SPX41 10PK	40	RE 841 Phosphor (1, 2, 5, 8)*	16.5	2850	2510	12000	4100	82	50F	(10)		
40	2G11	16953	F40/30BX/SPX30 10PK	40	RE 830 Phosphor (1, 2, 8, 17)*	22.5	3150	2840	20000	3000	82	50F	(10)		
		20444	F40/30BX/SPX30 36PK	36	RE 830 Phosphor, Bulk Pack (1, 2, 8, 17)*	22.5	3150	2840	20000	3000	82	50F	(10)		
		16648	F40/30BX/SPX35 10PK	40	RE 835 Phosphor (1, 2, 8, 17)*	22.5	3150	2840	20000	3500	82	50F	(10)		
		20446	F40/30BX/SPX35 36PK	36	RE 835 Phosphor, Bulk Pack (1, 2, 8, 17)*	22.5	3150	2840	20000	3500	82	50F	(10)		
		16954	F40/30BX/SPX41 10PK	40	RE 841 Phosphor (1, 2, 8, 17)*	22.5	3150	2840	20000	4100	82	50F	(10)		
		20447	F40/30BX/SPX41 36PK	36	RE 841 Phosphor, Bulk Pack (1, 2, 8, 17)*	22.5	3150	2840	20000	4100	82	50F	(10)		
		10490	F40/30BX/SPX50/RS 36PK	36	RE 850 Phosphor, Bulk Pack (1, 2, 8, 17)*	22.5	2900	2700	20000	5000	80	50F	(10)		
		50	2G11	20898	F50BX/SPX30/RS 10PK	40	RE 830 Phosphor (1, 2, 5, 8)*	22.5	4000	3400	14000	3000	82	50F	(10)
		20899	F50BX/SPX35/RS 10PK	40	RE 835 Phosphor (1, 2, 5, 8)*	22.5	4000	3400	14000	3500	82	50F	(10)		
		20900	F50BX/SPX41/RS 10PK	40	RE 841 Phosphor (1, 2, 5, 8)*	22.5	4000	3400	14000	4100	82	50F	(10)		

DOUBLE BIAX® PLUG-IN LAMPS - T4

2-PIN BASE

9	G23-2	12409	F9DBX23T4/SPX27/827	50	RE 827 Phosphor (1, 2)*	4.3	550	470	10000	2700	82	25F	(-4)		
13	GX23-2	18844	F13DBX23T4/SPX27 10PK	50	RE 827 Phosphor (1, 2)*	4.7	810	685	10000	2700	82	32F	(0)		
		13578	F13DBX/SPX27/CD	6	RE 827 Phosphor, Carded (1, 2)*	4.7	810	685	10000	2700	82	32F	(0)		
		10574	F13DBX23T4/SPX30 10PK	50	RE 830 Phosphor (1, 2)*	4.7	810	685	10000	3000	82	32F	(0)		
		18556	F13DBX23T4/SPX35 10PK	50	RE 835 Phosphor (1, 2)*	4.7	810	685	10000	3500	82	32F	(0)		
		20531	F13DBX23T4/SPX41 10PK	50	RE 841 Phosphor (1, 2)*	4.7	810	685	10000	4100	82	32F	(0)		
13	G24d-1	18557	F13DBXT4/SPX27 10PK	50	RE 827 Phosphor (1, 2)*	5.3	900	765	10000	2700	82	5F	(-15)		
		12956	F13DBXT4/SPX30 10PK	50	RE 830 Phosphor (1, 2)*	5.3	900	765	10000	3000	82	32F	(0)		
		18559	F13DBXT4/SPX35 10PK	50	RE 835 Phosphor (1, 2)*	5.3	900	765	10000	3500	82	5F	(-15)		
		20532	F13DBXT4/SPX41 10PK	50	RE 841 Phosphor (1, 2)*	5.3	900	765	10000	4100	82	5F	(-15)		
18	G24d-2	12860	F18DBXT4/SPX27 10PK	50	RE 827 Phosphor (1, 2, 6)*	6.1	1150	980	10000	2700	82	5F	(-15)		
		12861	F18DBXT4/SPX30 10PK	50	RE 830 Phosphor (1, 2, 6)*	6.1	1150	980	10000	3000	82	5F	(-15)		
		12863	F18DBXT4/SPX35 10PK	50	RE 835 Phosphor (1, 2, 6)*	6.1	1150	980	10000	3500	82	5F	(-15)		
		12864	F18DBXT4/SPX41 10PK	50	RE 841 Phosphor (1, 2, 6)*	6.1	1150	980	10000	4100	82	5F	(-15)		
26	G24d-3	35250	F26DBXT4/SPX27	50	RE 827 Phosphor (1, 2)*	6.7	1710	1460	10000	2700	82	15F	(-9)		
		35237	F26DBXT4/SPX30	50	RE 830 Phosphor (1, 2)*	6.7	1710	1460	10000	3000	82	15F	(-9)		
		35251	F26DBXT4/SPX35	50	RE 835 Phosphor (1, 2)*	6.7	1710	1460	10000	3500	82	15F	(-9)		
		35252	F26DBXT4/SPX41	50	RE 841 Phosphor (1, 2)*	6.7	1710	1460	10000	4100	82	15F	(-9)		



Watts	Base	Product Code	Lamp Description	Case Qty.	Additional Information	Nominal Length in.	Lumens		Rated Avg. Life Hours	Color Temp		Min. Start Temp F	Power Factor	THD
							Initial	Mean		K	CRI			
DOUBLE BIAX® PLUG-IN LAMPS (Continued)														
4-PIN BASE														
	13 G24q-1	30035	↔ F13DBX/SPX27/4P 10PK	50	RE 827 Phosphor (1, 2, 8)*	5.0	900	765	10000	2700	82	32F	(0)	
		10580	↔ F13DBX/SPX30/4P 10PK	50	RE 830 Phosphor (1, 2, 8)*	5.0	900	765	10000	3000	82	32F	(0)	
		30037	↔ F13DBX/SPX35/4P 10PK	50	RE 835 Phosphor (1, 2, 8)*	5.0	900	765	10000	3500	82	32F	(0)	
		30038	↔ F13DBX/SPX41/4P 10PK	50	RE 841 Phosphor (1, 2, 8)*	5.0	900	765	10000	4100	82	32F	(0)	
	18 G24q-2	12865	↔ F18DBX/SPX27/4P 10PK	50	RE 827 Phosphor (1, 2, 6, 8)*	5.8	1150	980	10000	2700	82	32F	(0)	
		12866	↔ F18DBX/SPX30/4P 10PK	50	RE 830 Phosphor (1, 2, 6, 8)*	5.8	1150	980	10000	3000	82	32F	(0)	
		12869	↔ F18DBX/SPX35/4P 10PK	50	RE 835 Phosphor (1, 2, 6, 8)*	5.8	1150	980	10000	3500	82	32F	(0)	
		12870	↔ F18DBX/SPX41/4P 10PK	50	RE 841 Phosphor (1, 2, 6, 8)*	5.8	1150	980	10000	4100	82	32F	(0)	
	26 G24q-3	35247	↔ F26DBXT4/SPX27/4P	50	RE 827 Phosphor (1, 2, 8)*	6.4	1710	1460	10000	2700	82	32F	(0)	
		35235	↔ F26DBXT4/SPX30/4P	50	RE 830 Phosphor (1, 2, 8)*	6.4	1710	1460	10000	3000	82	32F	(0)	
		35248	↔ F26DBXT4/SPX35/4P	50	RE 835 Phosphor (1, 2, 8)*	6.4	1710	1460	10000	3500	82	32F	(0)	
		35236	↔ F26DBXT4/SPX41/4P	50	RE 841 Phosphor (1, 2, 8)*	6.4	1710	1460	10000	4100	82	32F	(0)	
TRIPLE BIAX® PLUG-IN LAMPS - T4														
4-PIN BASE														
	13 GX24q-1	34391	↔ F13TBX/SPX27/A/4P	10	RE 827 Phosphor, Amalgam (1, 2, 8, 15)*	4.2	900	765	10000	2700	82	32F	(0)	
		34395	↔ F13TBX/SPX30/A/4P	10	RE 830 Phosphor, Amalgam (1, 2, 8, 15)*	4.2	900	765	10000	3000	82	32F	(0)	
		34400	↔ F13TBX/SPX35/A/4P	10	RE 835 Phosphor, Amalgam (1, 2, 8, 15)*	4.2	900	765	10000	3500	82	32F	(0)	
		34387	↔ F13TBX/SPX41/A/4P	10	RE 841 Phosphor, Amalgam (1, 2, 8, 15)*	4.2	900	765	10000	4100	82	32F	(0)	
	18 GX24q-2	34392	↔ F18TBX/SPX27/A/4P	10	RE 827 Phosphor, Amalgam (1, 2, 8, 15)*	4.8	1200	1020	10000	2700	82	32F	(0)	
		34396	↔ F18TBX/SPX30/A/4P	10	RE 830 Phosphor, Amalgam (1, 2, 8, 15)*	4.8	1200	1020	10000	3000	82	32F	(0)	
		34405	↔ F18TBX/SPX35/A/4P	10	RE 835 Phosphor, Amalgam (1, 2, 8, 15)*	4.8	1200	1020	10000	3500	82	32F	(0)	
		34385	↔ F18TBX/SPX41/A/4P	10	RE 841 Phosphor, Amalgam (1, 2, 8, 15)*	4.8	1200	1020	10000	4100	82	32F	(0)	
	26 GX24q-3	34393	↔ F26TBX/SPX27/A/4P	10	RE 827 Phosphor, Amalgam (1, 2, 8, 15)*	5.2	1800	1530	10000	2700	82	32F	(0)	
		34397	↔ F26TBX/SPX30/A/4P	10	RE 830 Phosphor, Amalgam (1, 2, 8, 15)*	5.2	1800	1530	10000	3000	82	32F	(0)	
		34406	↔ F26TBX/SPX35/A/4P	10	RE 835 Phosphor, Amalgam (1, 2, 8, 15)*	5.2	1800	1530	10000	3500	82	32F	(0)	
		34381	↔ F26TBX/SPX41/A/4P	10	RE 841 Phosphor, Amalgam (1, 2, 8, 15)*	5.2	1800	1530	10000	4100	82	32F	(0)	
	32 GX24q-3	34394	↔ F32TBX/SPX27/A/4P	10	RE 827 Phosphor, Amalgam (1, 2, 8, 15)*	5.8	2200	1870	10000	2700	82	32F	(0)	
		34399	↔ F32TBX/SPX30/A/4P	10	RE 830 Phosphor, Amalgam (1, 2, 8, 15)*	5.8	2200	1870	10000	3000	82	32F	(0)	
		34388	↔ F32TBX/SPX35/A/4P	10	RE 835 Phosphor, Amalgam (1, 2, 8, 15)*	5.8	2200	1870	10000	3500	82	32F	(0)	
		34380	↔ F32TBX/SPX41/A/4P	10	RE 841 Phosphor, Amalgam (1, 2, 8, 15)*	5.8	2200	1870	10000	4100	82	32F	(0)	









To save energy costs, find the bulbs with the light output you need, then choose the one with the lowest watts.

() * All footnote references found at the end of this section. ↔ Reduced Wattage ↻ High Color Rendering.

To convert inches to millimeters, multiply by 25.4.

Compact Fluorescent Lamps



Watts	Base	Product Code	Lamp Description	Case Qty.	Additional Information	Nominal Length in.	Lumens Initial	Lumens Mean	Rated Avg. Life Hours	Color Temp K.	CRI	Min. Start Temp F	Min. Start Temp (°C)	Power Factor	THD
TRIPLE BIAX® PLUG-IN LAMPS - T4 (Continued)															
INVERTED BASE															
	13 GX24q-1	25799	↔ F13TBX/I/827/A/4P	10	RE 827 Phosphor, Inverted Post, Amalgam (1, 2, 8, 15)*	3.4	900	765	10000	2700	82	32F	(0)		
		25800	↔ F13TBX/I/830/A/4P	10	RE 830 Phosphor, Inverted Post, Amalgam (1, 2, 8, 15)*	3.4	900	765	10000	3000	82	32F	(0)		
		25801	↔ F13TBX/I/835/A/4P	10	RE 835 Phosphor, Inverted Post, Amalgam (1, 2, 8, 15)*	3.4	900	765	10000	3500	82	32F	(0)		
	18 GX24q-2	25802	↔ F18TBX/I/827/A/4P	10	RE 827 Phosphor, Inverted Post, Amalgam (1, 2, 8, 15)*	3.9	1200	1020	10000	2700	82	32F	(0)		
		25803	↔ F18TBX/I/830/A/4P	10	RE 830 Phosphor, Inverted Post, Amalgam (1, 2, 8, 15)*	3.9	1200	1020	10000	3000	82	32F	(0)		
		25804	↔ F18TBX/I/835/A/4P	10	RE 835 Phosphor, Inverted Post, Amalgam (1, 2, 8, 15)*	3.9	1200	1020	10000	3500	82	32F	(0)		
QUAD BIAX® PLUG-IN LAMPS-T4															
4-PIN BASE															
	42 GX24q-4	44795	↔ F42QBX/SPX30/A/4P	6	RE 830 Phosphor, Amalgam (1, 2, 8, 15)*	6.0	3200	2720	10000	3000	82	32F	(0)		
		34834	↔ F42QBX/SPX35/A/4P	6	RE 835 Phosphor, Amalgam (1, 2, 8, 15)*	6.0	3200	2720	10000	3500	82	32F	(0)		
		44796	↔ F42QBX/SPX41/A/4P	6	RE 841 Phosphor, Amalgam (1, 2, 8, 15)*	6.0	3200	2720	10000	4100	82	32F	(0)		
GENURA™															
	23 Med	12273	↔ EL23/R25/WW	6	Genura, Warm White (18)*	4.9	1100	880	15000	3000	82	32F	(0)	<.55	130%
		25418	↔ EL23/R25/SW	6	Genura, Soft White (18)*	4.9	1100	880	15000	2700	82	32F	(0)	<.55	130%
ELECTRONIC SELF BALLASTED LAMPS															
	15 Med	12544	↔ FLE15TBX/L/SPX27	6	RE 827 Phosphor, Soft White, Triple Biax®, Slimshell Ballast (1, 9, 11, 12, 15)*	5.2	900	765	10000	2700	82	-10F (-23)	<.6	170%	
		27188	↔ FLE15TBX/L/SW/CD	3	RE 827 Phosphor, Soft White, Triple Biax®, Slimshell Ballast, Carded (1, 9, 11, 12, 15)*	5.2	900	765	10000	2700	82	-10F (-23)	<.6	170%	
		12981	↔ FLE15TBX/HPF/SPX27/SW	6	RE 827 Phosphor, Soft White Ultra, Triple Biax®, High Power Factor, Shortshell Ballast (1, 9, 11, 12, 15)*	6.0	825	700	10000	2700	82	-10F (-23)	>.9	<32%	
		13105	↔ FLE15TBX/L/R30	6	RE 827 Phosphor, Soft White, R30 Reflector Slimshell Ballast (1, 9, 11, 12, 13, 15)*	5.5	515	440	10000	2700	82	-10F (-23)	<.6	170%	
		12501	↔ FLE15TBX/L/G29	6	RE 827 Phosphor, Soft White, G30 Globe Slimshell Ballast (1, 9, 11, 12, 15)*	5.8	695	600	10000	2700	82	-10F (-23)	<.6	170%	
		80506	↔ FLG15/E-120	6	RE 827 Phosphor, Soft White Ultra, Globe Shaped (1, 9, 10, 11, 12)*	5.1	765	575	10000	2800	82	0F (-18)	0.5	<150%	

Compact Fluorescent Lamps



Watts	Base	Product Code	Lamp Description	Case Qty.	Additional Information	Nominal Length in.	Lumens		Rated Avg. Life Hours	Color Temp K	CRI	Min. Start Temp (°C)	Power Factor	THD
							Initial	Mean						
ELECTRONIC SELF BALLASTED LAMPS (Continued)														
	20 Med	12545	➤ FLE20TBX/L/SPX27	6	RE 827 Phosphor, Soft White, Triple Biax®, Slimshell Ballast (1, 9, 11, 12, 15)*	5.8	1200	1020	10000	2700	82	-10F (-23)	<.6	170%
		27189	➤ FLE20TBX/L/SW/CD	3	RE 827 Phosphor, Soft White, Triple Biax®, Slimshell Ballast, Carded (1, 9, 11, 12, 15)*	5.8	1200	1020	10000	2700	82	-10F (-23)	<.6	170%
		12987	➤ FLE20TBX/HPF/SPX27/SW	6	RE 827 Phosphor, Soft White Ultra, Triple Biax®, High Power Factor, Shortshell Ballast (1, 9, 11, 12, 15)*	5.8	1200	1020	10000	2700	82	-10F (-23)	>.9	<32%
		40332	➤ FLE20TBX/L/R40	6	RE 827 Phosphor, R40 Reflector W/Lens, Slimshell Ballast (1, 9, 11, 12, 15)*	6.2	785	670	10000	2700	82	-10F (-23)	<.6	170%
		13174	➤ FLE20TBX/HPF/RFL/SW	6	RE 827 Phosphor, Soft White Ultra, Triple Biax®, High Power Factor, R40 Reflector, Shortshell Ballast, No Lens (1, 9, 11, 12, 15)*	6.2	885	750	10000	2700	82	-10F (-23)	0.95	<20%
	24 Med	12546	➤ FLE24TBX/SPX27	6	RE 827 Phosphor - Soft White, Triple Biax®, Standard Shell Ballast (1, 9, 11, 15, 18)*	6.7	1520	1290	10000	2700	82	-10F (-23)	<.6	170%
	25 Med	12990	➤ FLE25TBX/HPF/SPX27/SW	6	RE 827 Phosphor, Soft White Ultra, Triple Biax®, High Power Factor, Standard Shell Ballast (1, 9, 11, 15, 18)*	6.9	1520	1290	10000	2700	82	-10F (-23)	>.9	<32%
	28 Med	13129	➤ FLE28QBX/SPX27	6	RE 827 Phosphor, Soft White, Performance Biax®, Standard Shell Ballast (1, 9, 11, 15, 18)*	6.3	1750	1485	10000	2700	82	-10F (-23)	<.6	170%
		27191	➤ FLE28QBX/SW/CD	3	RE 827 Phosphor, Soft White, Performance Biax®, Carded, Standard Shell Ballast (1, 9, 11, 15, 18)*	6.3	1750	1485	10000	2700	82	-10F (-23)	<.6	170%
ELECTROMAGNETIC SELF BALLASTED LAMPS														
	17 Med	80503	➤ FLB17	6	RE 827 Phosphor, Bullet Shape (1, 9, 10, 11, 12)*	6.7	700	595	9000	2800	82	32F (0)	0.5	<32%
		80504	➤ FLG17	6	RE 827 Phosphor, Globe Shape (1, 9, 10, 11, 12)*	6.4	700	595	9000	2800	82	32F (0)	0.5	<32%
BIAX® PLUG-IN LAMPS WITH SEPARABLE ELECTROMAGNETIC ADAPTERS														
	9 Med	80508	➤ FLA5/SPX27	6	RE 827 Phosphor, Biax® (1, 9, 11, 14)*	6.5	250	210	10000	2700	82	32F (0)	0.5	<20%
		80510	➤ FLA7/SPX27	6	RE 827 Phosphor, Biax® (1, 9, 11, 14)*	7.7	375	320	10000	2700	82	32F (0)	0.5	<20%
		80511	➤ FLA9/SPX27	6	RE 827 Phosphor, Biax® (1, 9, 11, 14)*	8.8	500	425	10000	2700	82	32F (0)	0.5	<20%
	11 Med	20659	➤ FLA9BX/SPX27	5	RE 827 Phosphor, Biax® (1, 9, 11, 14)*	7.9	570	10000	2700	82	25F (-4)	0.5	10-15%	
	13 Med	80507	➤ FLA13/SPX27	6	RE 827 Phosphor (1, 9, 11, 14)*	7.2	750	635	10000	2700	82	32F (0)	0.9	<32%
	21 Med	11307	➤ FCA21/CD	4	RE 830 Phosphor, Circlite, Carded, FC8T9/KB Replacement Lamp (1, 9, 11, 14)*	3.4	1200	1020	10000	3000	82	50F (10)	0.5	<20%
		14681	FCA21/BLB	4	Blacklight, UVA Source, Peak Emission 365nm	3.4			10000					

To save energy costs, find the bulbs with the light output you need, then choose the one with the lowest watts.

(*) * All footnote references found at the end of this section. ➤ Reduced Wattage Ⓢ High Color Rendering. To convert inches to millimeters, multiply by 25.4.

Compact Fluorescent Lamps



Watts	Base	Product Code	Lamp Description	Case Qty.	Additional Information	Nominal Length in.	Lumens Initial	Lumens Mean	Rated Avg. Life Hours	Color Temp K	CRI	Min. Start Temp F	Start Temp (°C)	Power Factor	THD
2D® PLUG-IN LAMPS WITH SEPARABLE ELECTRONIC ADAPTERS															
	22 Med	25805	FEA212D/827-BULK	20	RE 827 Phosphor, 2D®, Bulk Pack (1, 4, 9, 11, 14)*	4.0	1300	1105	10000	2700	82	32F	(0)	0.5	170%
		25806	FEA212D/835-BULK	20	RE 835 Phosphor, 2D®, Bulk Pack (1, 4, 9, 11, 14)*	4.0	1300	1105	10000	3500	82	32F	(0)	0.5	170%
		26631	FEA212D/SW/EC/CD	4	RE 827 Phosphor, Carded, Uses F212D/827 Replacement Lamp (1, 4, 9, 14, 18)*	4.0	1300	1105	10000	2700	82	32F	(0)	0.5	170%
	39 Med	25807	FEA382D/827-BULK	20	RE 827 Phosphor, 2D®, Bulk Pack (1, 4, 9, 14, 18)*	4.3	2780	2365	10000	2700	82	32F	(0)	0.5	170%
		25808	FEA382D/835-BULK	20	RE 835 Phosphor, 2D®, Bulk Pack (1, 4, 9, 14, 18)*	4.3	2780	2365	10000	3500	82	32F	(0)	0.5	170%
		18739	FEA382D/SW/CD	4	RE 827 Phosphor, Carded, Uses F382D/827 Replacement Lamp (1, 4, 9, 14, 18)*	4.0	2780	2365	10000	2700	82	32F	(0)	0.5	170%
	15 Med	25809	FEA382D/3W/827/B	20	RE 827 Phosphor, 3-Way, Bulk Pack (1, 4, 9, 14, 18)*	4.3	750	640	10000	2700	82	32F	(0)	0.5	170%
		25812	FEA382D/3W/835/B	20	RE 835 Phosphor, 3-Way, Bulk Pack (1, 4, 9, 14, 18)*	4.3	750	640	10000	3500	82	32F	(0)	0.5	170%
		27253	FEA382D/3WAY/CD	4	RE 827 Phosphor, 3-Way, Carded Uses F382D/827 Replacement Lamp (1, 4, 9, 14, 18)*	4.3	750	640	10000	2700	82	32F	(0)	0.5	170%
	39 Med	11526	FEA392D/HPF/SW/CD	6	RE 827 Phosphor - Soft White Ultra, High Power Factor, Uses F382D/827 Replacement Lamp (1, 4, 9, 11, 14)*	4.3	2780	2360	10000	2700	82	0F (-18)		>.9	<20%
TRIPLE BIAX® PLUG-IN LAMPS WITH SEPARABLE ELECTRONIC ADAPTERS															
	15 Med	25790	FEA13TBX/I/827/B	10	RE 827 Phosphor, Inverted Post, Replacement Lamp F13TBX/I/827/4P (1, 12, 14, 15)*	5.9	775	660	10000	2700	82	32F	(0)	0.5	170%
		27623	FEA13TBX/I/827 6PK	6	RE 827 Phosphor, Inverted Post, Replacement Lamp F13TBX/I/827/4P (1, 12, 14, 15)*	5.9	775	660	10000	2700	82	32F	(0)	0.5	170%
		25791	FEA13TBX/I/830/B	10	RE 830 Phosphor, Inverted Post, Replacement Lamp F13TBX/I/830/4P (1, 12, 14, 15)*	5.9	775	660	10000	3000	82	32F	(0)	0.5	170%
		25792	FEA13TBX/I/835/B	10	RE 835 Phosphor, Inverted Post, Replacement Lamp F13TBX/I/835/4P (1, 12, 14, 15)*	5.9	775	660	10000	3500	82	32F	(0)	0.5	170%
	20 Med	25793	FEA18TBX/I/827/B	10	RE 827 Phosphor, Inverted Post, Replacement Lamp F18TBX/I/827/4P (1, 12, 14, 15)*	6.5	1100	935	10000	2700	82	32F	(0)	0.5	170%
		27624	FEA18TBX/I/827 6PK	6	RE 827 Phosphor, Inverted Post, Replacement Lamp F18TBX/I/827/4P (1, 12, 14, 15)*	6.5	1100	935	10000	2700	82	32F	(0)	0.5	170%
		25797	FEA18TBX/I/830/B	10	RE 830 Phosphor, Inverted Post, Replacement Lamp F18TBX/I/830/4P (1, 12, 14, 15)*	6.5	1100	935	10000	3000	82	32F	(0)	0.5	170%
		25798	FEA18TBX/I/835/B	10	RE 835 Phosphor, Inverted Post, Replacement Lamp F18TBX/I/835/4P (1, 12, 14, 15)*	6.5	1100	935	10000	3500	82	32F	(0)	0.5	170%



Watts	Base	Product Code	Lamp Description	Case Qty.	Additional Information	Nominal Length in.	Lumens		Rated Avg. Life Hours	Color Temp.		Min. Start Temp.		Power Factor	THD
							Initial	Mean		K	CRI	F	(°C)		

BIAX® SCREW-IN ADAPTERS

9	Med	16217	FLA7/9 BULK	50	Bulk Pack, Contains 50 Screw-In Adapters to Operate F7BX or F9BX Biax Lamps	2.9			4000						
---	-----	-------	-------------	----	---	-----	--	--	------	--	--	--	--	--	--

CFL REFLECTOR LENSES

25448	LENS-CFL/R30/PINK	100	Lens, Pink, R30, Fits 13105 FLE15TBX/L/R30
25449	LENS-CFL/R30/RED	100	Lens, Red, R30, Fits 13105 FLE15TBX/L/R30
25451	LENS-CFL/R40/PINK	100	Lens, Pink, R40, Fits 40332 FLE20TBX/L/R40

LOCKING DEVICE



26632	LOCKDEVICE-UNIVERSAL	100	Locking Device, All FEA products plus Slimshell.
-------	----------------------	-----	--



25455	LOCKDEVICE-SHRT	100	Locking Device, All Short Shell Products
-------	-----------------	-----	--



25454	LOCKDEVICE-STND	100	Locking Device, All Standard Shell Products
-------	-----------------	-----	---

BRIGHT STIK® LIGHTING UNIT

33	12257	FBS25/WX/PP	6	Bright Stik, White Lamp-In-Holder Unit with Standard 2-Prong Plug, Integral Lamp(1)*	25	725	7500	3450	59
	47912	FBS25/BLB/PP	6	Bright Stik, Blacklight Blue Lamp-In-Holder Unit with Standard 2-Prong Plug, Integral Lamp (1)*	25		7500		
	12263	FBS25/GS/PP	6	Bright Stik, Gro & Sho Lamp-In-Holder Unit with Standard 2-Prong Plug, Integral Lamp (1)*	25	470	7500	3050	90

FOOTNOTES

Footnote

- Fluorescent lamp lumens decline during life.
- Based on 60Hz reference circuit.
- 10-watt, 16-watt and 28-watt 2D® lamps may be operated in any position. 21-watt, 38-watt, 39-watt, and 55-watt 2D® lamps must be used with the leg marked (a) in the diagram below the bend (b), in order to avoid overheating the end of the cap marked (c).
- Life ratings for the F18BX Preheat lamps are based on operating the lamp at 3 hrs. per start on a preheat type circuit. Operation on rapid start and instant start ballasts is not recommended. Life ratings for all lamps are based on operating the lamp at 3 hrs. per start on a rapid start type ballast. Life rating on a preheat or instant start ballast is 25% lower than other Rapid Start High Lumen Biax®.
- Cold cathode resistance is approximately 6.0 Ohms.
- Typically not used in under cabinet applications.
- 4-Pin lamp minimum starting temperature is a function of the ballast. Most ballasts are rated with a minimum starting temperature of 50° F (10° C). Ballasts are also available that provide reliable starting to 0° F (-18° C) and -20° F (-29° C).
- One piece self ballasted lamps for incandescent sockets and plug-in lamps with screw-in adapters do not work with clip-on shades.
- Lumens on one piece self ballasted lamp systems are measured base up. When operated base down, lumens may decrease > 5%.
- Best performance if operated base up and at 77° F (25° C) ambient temperature.
- Use only on 120V 60Hz circuits. Do not use on dimming circuits or timers. Use indoors and do not use in wet locations. Not for use in totally enclosed recessed fixtures.
- Fits most R30 applications.
- Adapters rated at 40,000 hours life.
- Amalgam product experience stable brightness over a wider temperature range and in various operating positions.
- Life ratings based on rapid start operation. On instant start ballast, life rating is 25% lower.
- Use only on 120v 60Hz circuits. Do not use on dimming circuits or timers.

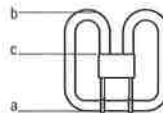





GENERAL INFORMATION

Bulb Identification Guide 6-2
Lamp Locator 6-2
Filament Identification 6-4
Base Identification 6-4
Introduction 6-5
General Information 6-5
Catalog Headings 6-6
Stage and Studio ANSI Codes 6-10
Footnotes 6-11

STAGE & STUDIO LAMPS

Incandescent Lamps 6-6
Quartzline® 6-6
Quartzline® High Voltage 6-9



BULB IDENTIFICATION

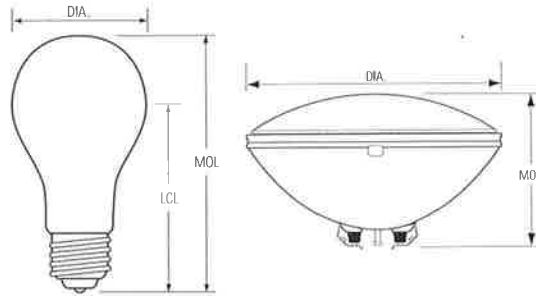

DIA: Diameter of bulb at widest point.
 MOL: Maximum Overall Length including base or pins.

LCL: Distance between the center of the arc tube and the Light Center Length reference plane.

Note: Lamp drawings are not drawn to scale. Be sure to check size and dimension information when identifying each lamp.

To convert inches to millimeters, multiply the dimension (in inches) by 25.4 (i.e. inches x 25.4 = millimeters).

LAMP LOCATOR

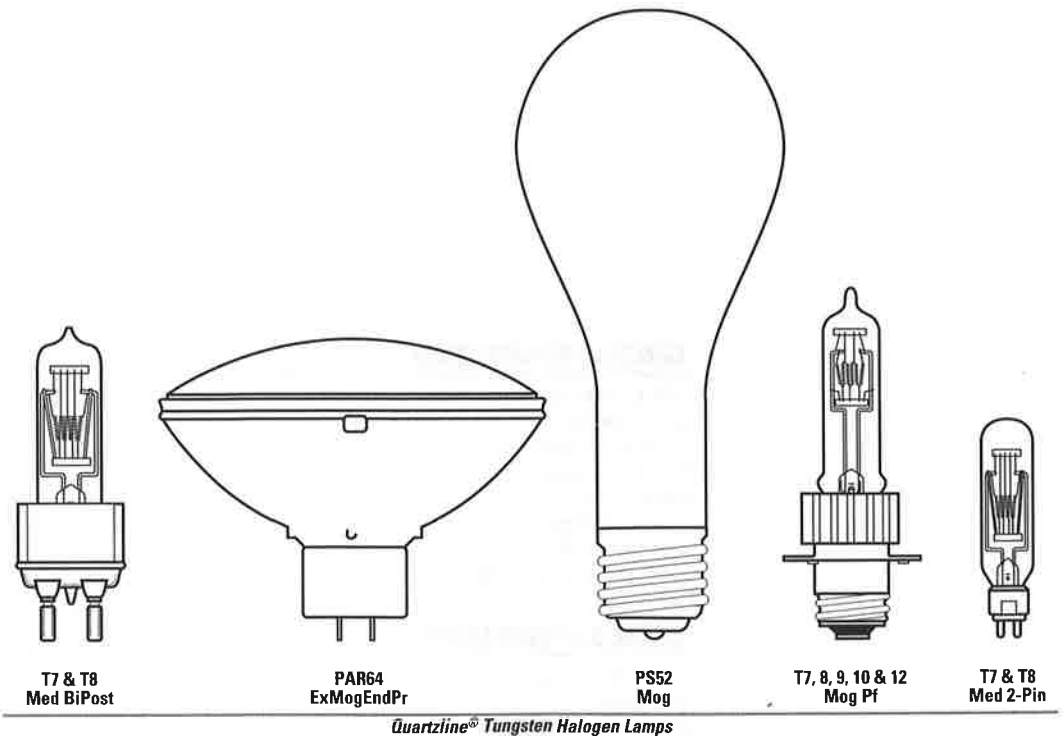
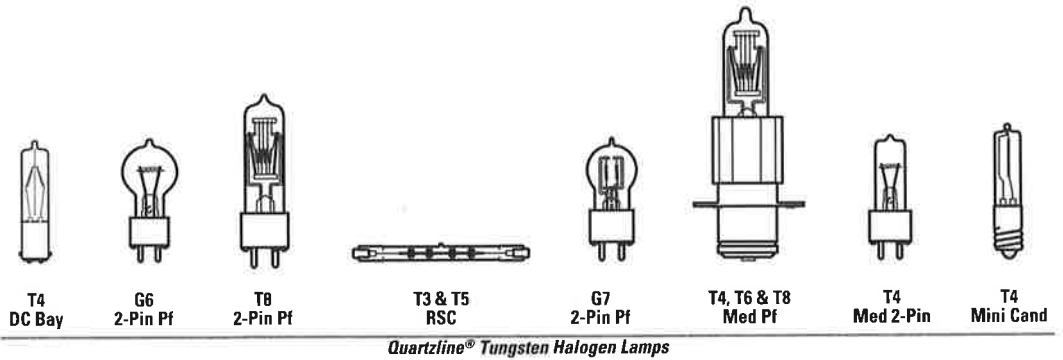

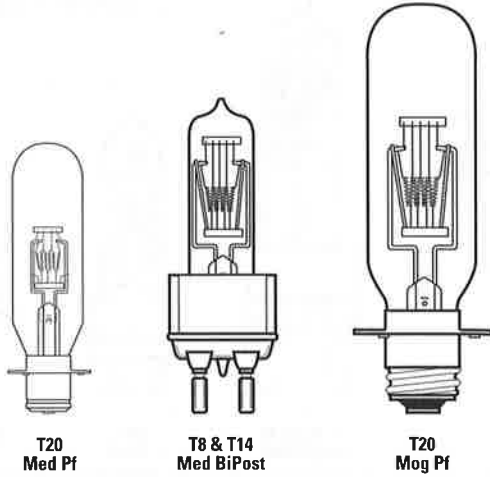

T20
Med Pf

T8 & T14
Med BiPost

T20
Mog Pf

Incandescent Lamps

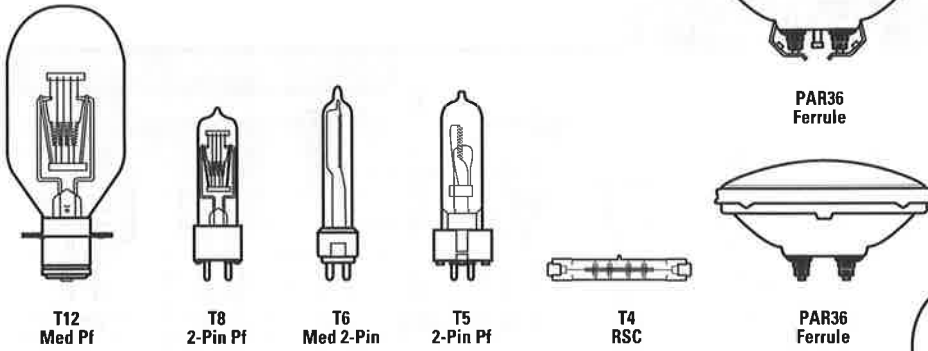

T12
Med Pf

T8
2-Pin Pf

T6
Med 2-Pin

T5
2-Pin Pf

T4
RSC

PAR36
Ferrule

PAR36
Ferrule

Quartzline® Tungsten Halogen Lamps

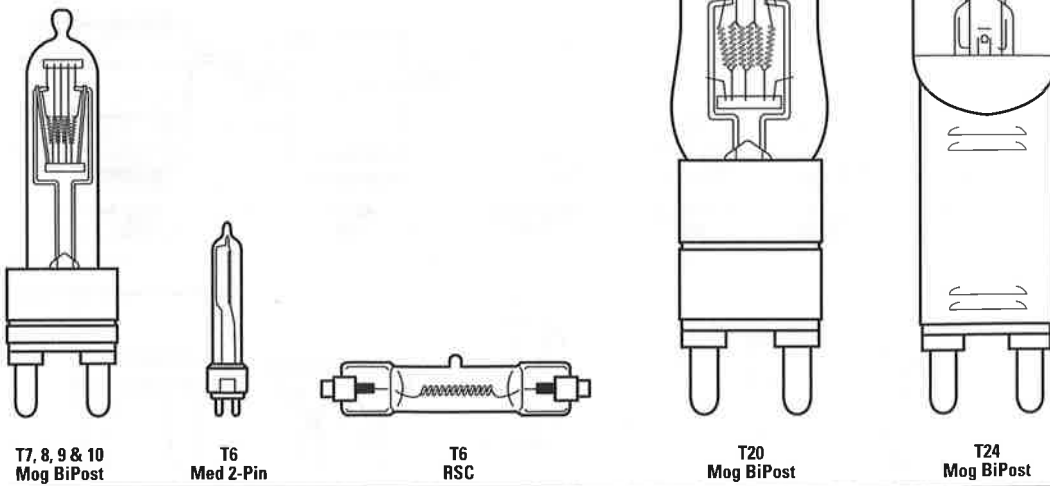

T7, 8, 9 & 10
Mog BiPost

T6
Med 2-Pin

T6
RSC

T20
Mog BiPost

T24
Mog BiPost

Quartzline® Tungsten Halogen Lamps

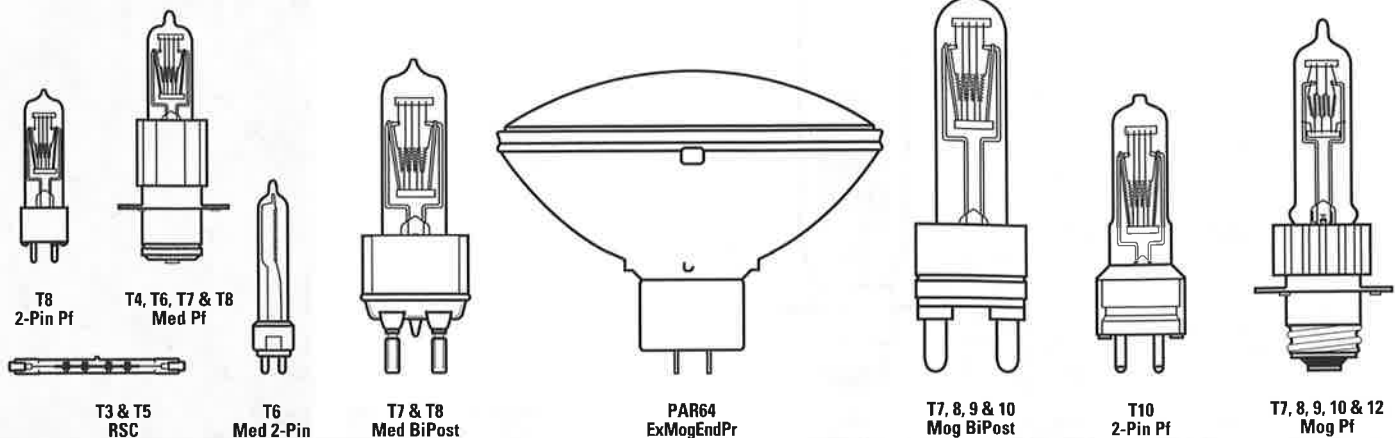

T8
2-Pin Pf

T4, T6, T7 & T8
Med Pf

T6
Med 2-Pin

T3 & T5
RSC

T7 & T8
Med BiPost

PAR64
ExMogEndPr

T7, 8, 9 & 10
Mog BiPost

T10
2-Pin Pf

T7, 8, 9, 10 & 12
Mog Pf

Quartzline® Tungsten Halogen High Voltage Lamps

FILAMENT IDENTIFICATION

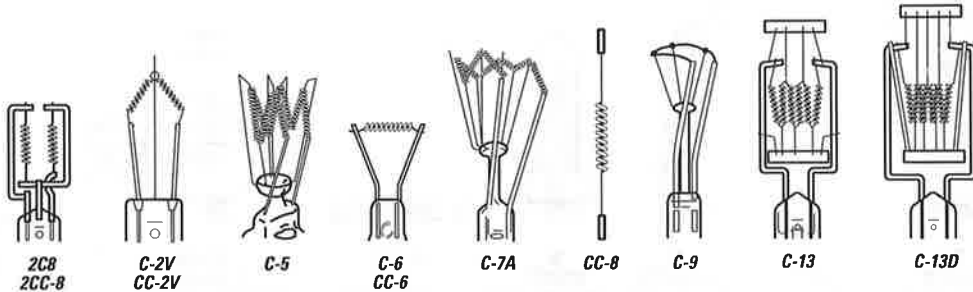

2C8
2CC-8

C-2V
CC-2V

C-5

C-6
CC-6

C-7A

CC-8

C-9

C-13

C-13D

BASE IDENTIFICATION

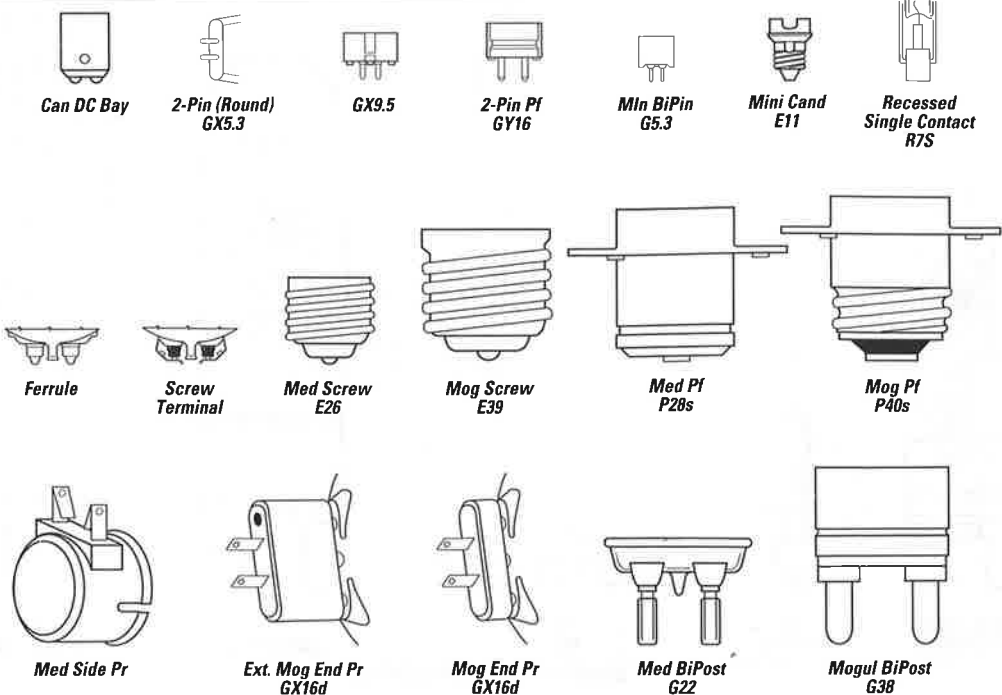

Can DC Bay

2-Pin (Round)
GX5.3

GX9.5

2-Pin Pf
GY16

MIn BiPin
G5.3

Mini Cand
E11

Recessed
Single Contact
R7S

Ferrule

Screw
Terminal

Med Screw
E26

Mog Screw
E39

Med Pf
P28s

Mog Pf
P40s

Med Side Pr

Ext. Mog End Pr
GX16d

Mog End Pr
GX16d

Med BiPost
G22

Mogul BiPost
G38



INTRODUCTION

GE Lighting has been a leading supplier to stage and studio users for many decades, and continues its pioneering work in the development of new and innovative light sources.

The primary change in recent years has been the migration from glass to quartz as the standard bulb material. The higher melting point of quartz enables bulb envelopes to be reduced in size and the halogen fillings to be run at higher pressures, leading to smaller, lighter, brighter, more energy-efficient and more reliable lamps.

GE Lighting's comprehensive range of single- and double-ended lamps is complemented by a group of PAR lamps, where the light source is enclosed in a sealed reflector unit.

The beam patterns of PAR lamps range from very narrow spot to wide-angle floods. This ensures consistency from lamp to lamp, interchangeability to suit the beam pattern needs of the moment and instant replaceability without the need to refocus and re-aim fixtures.

The sealed beam design prolongs the life of the inner lamp as well as protecting it from dust, vapor and other hazards, thereby ensuring high lumen maintenance over the life of the lamp.

PAR lamps may be used with very simple, lightweight, economical fixtures.

GENERAL INFORMATION

OPERATIONAL CHARACTERISTICS

Quartz halogen lamps are designed to be operated within close voltage tolerances, and excessive voltage can lead to drastically shortened life, albeit with significantly higher light output.

A second important variable is temperature. The tungsten halogen cycle does not operate properly below about 482°F (250°C) and quartz may begin to devitrify above about 1832°F (1000°C). Bulb envelopes should therefore be held in the range 482-1472°F (250-800°C).

The rate of oxidation of the sealing foil carrying current from the base to the filament through the quartz envelope increases with temperature above 662°F (350°C), and lamp life may be severely curtailed by premature seal failure if this temperature is exceeded.

The contact pins are plated to ensure good electrical connection with the lampholder. However, at temperatures above 662°F (350°C), the plating may lose adhesion, leading to deterioration in contact and possibly local hot spots, arcing and consequent irreparable damage to both lamp and holder. Note that if there is evidence that this has occurred, the lampholder should be replaced before the next lamp is fitted, otherwise it is likely to fail prematurely for the same reason.

Lamps normally fail by fusing of the filament. This is often followed by arcing, leading to very high currents which can cause the envelope and seals to fail and the lamp to shatter. A quick-acting, high-breaking capacity fuse should therefore be connected to the supply line in all applications. Suitable types are given in IEC 127, 241 and 269.

LAMP CODES

GE Stage & Studio lamps are coded as such:

Lamp Description. This may be either an American National Standards Institute (ANSI) three letter code such as EJC, or a descriptive code in the general form Q750T3/4CL. ANSI codes are assigned to lamp specifications – mechanical, electrical and photometric characteristics – filed with the Institute.

They ensure interchangeability among similarly coded lamps from different manufacturers. Most of these lamps are rated for 120-volt operation. In a few cases a pair of ANSI codes are given (e.g. BFL/BFK), where the first is the official code for the lamp and the second code describes lamps the specifications of which are met or exceeded. In such cases, the lamps may be used to replace lamps with either code.

Base designations conform to IEC standards.



HEADINGS IN THIS CATALOG SECTION

The following terms and descriptions can help you when checking Stage/Studio lamp specifications and when ordering products. Within each product line, lamps are divided into families, within these families, lamps are then listed by wattage.

Watts:

Energy used. To find actual energy used (kWh) multiply power (watts shown) x time divided by 1000.

Case Quantity:

Number of product units packed in a case.

Filament Design:

Filaments are designated by a letter combination in which C is a coiled wire filament, CC is a coiled wire that is itself wound into a larger coil, and SR is a straight ribbon filament. Numbers represent the type of filament-support arrangement.

Color Temperature - Kelvins (K):

A measure of the visual "warmth" or "coolness" of the light from the lamp. The higher the value, the whiter or "cooler" the light appears.

Bulb:

Bulb shape followed by its size (the maximum diameter of the bulb expressed in eighths of an inch).

Volts:

Lamp data is based on operation at rated voltage.

LIF Code:

These are assigned by the Lighting Federation of London, U.K. They ensure electrical and mechanical interchangeability of similarly coded lamps. LIF codes are divided into groups according to the primary application of the lamps.

Product Code:

It is important to use this five-digit code when ordering to ensure that you receive the exact product you require.

Initial Lumens:

Initial light output.

LCL in.:

Distance between the center of the filament and the Light Center Length reference plane, in inches.

Approximate Beam Spread:

For reflector type lamps. The total angle of the directed beam (in degrees) to where the intensity of the beam falls to 50% or 10% of the maximum value as indicated.

Base:

The type of base.

Lamp Description:

The lamp's identification code.

Additional Information:

Typical application and/or other important information, including footnotes (†)*

Rated Average Life - Hours:

Lamp burning hours to median life expectancy.

MOL in.:

Maximum Overall Length in inches.

Watts	Bulb	Base	Product Code	Lamp Description	LIF Code	Case Qty.	Additional Information	Rated		Filament Design	MOL	LCL	Temp. K	Approx. Beam Spread	
								Initial Lumens	Avg. Life Hours					10%	50%
500	T12	Med Pf	21799	DEB-500T12/8		120 24		9000	800	C-13D	6 1/8	3 1/2	2850		

DEB- 500 T12/8

Identifies the lamp ANSI code

Identifies the lamp's wattage.

Identifies the lamp shape and the bulb diameter in eighths of inches.

WHEN YOU DON'T KNOW THE LAMP DESCRIPTION

1. Identify bulb shape by using tables on pages 6-2 - 6-4.
2. Measure bulb diameter using ruler in Appendix section page A-1 to determine width in eighths of an inch.
3. Identify base type using table on page 6-4.
4. Find your lamp in the table containing the bulb shape, size and base.

Watts	Bulb	Base	Product Code	Lamp Description	LIF Code	Case Qty.	Additional Information	Rated		Filament Design	MOL	LCL	Temp. K	Approx. Beam Spread	
								Initial Lumens	Avg. Life Hours					10%	50%
500	T12	Med Pf	21799	DEB-500T12/8		120 24		9000	800	C-13D	6 1/8	3 1/2	2850		
			21795	DNS-500T12/9 (29)		120 24 (29)*	11000	200	C-13D	6 1/8	3 1/2	2950			
	T14	Med 2-pin (G9.5)	21803	500T14/7		120 24	Clear, base up ± 30° (29)*	9000	800	C-13D	6 7/16	4	2850		

STAGE/STUDIO QUARTZLINE® TUNGSTEN HALOGEN LAMPS (ARRANGED IN WATTAGE ORDER)

200	T4	Cand DC Bay BA15d	14119	FEV-Q200/CL/DC		120 6	Clear	5500	50	CC-2V	2 7/16	1 3/8	3200		
300	T8	2-Pin Pf (GX9.5)	30455	FKW-Q300T8	CP81	120 50	Clear	7200	150	C-13	3 7/16	1 1 3/16	3200		
350	T3	R7S	20881	FDF/HIR-Q350T2/4CL		120 6	Halogen-IR, Clear (31)*	13250	400	C-8	4 11/16	2 3/8	3200		
420	G7	2-Pin Pf (GX9.5)	33934	EKB-Q420/4CL/2PP		120 24	Clear (15)*	11000	75	CC-6	2 1/2	1 7/16	3200		

Stage and Studio Lamps



Watts	Bulb	Base	Product Code	Lamp Description	LIF Code	Volts	Case Qty.	Additional Information	Rated			Temp. K	Approx. Beam Spread		
									Initial Lumens	Avg. Life Hours	Filament Design		MOL	LCL	10%
STAGE/STUDIO QUARTZLINE® TUNGSTEN HALOGEN LAMPS (ARRANGED IN WATTAGE ORDER) (Continued)															
500	T3	R7S	23735	FDI-Q500T3/4CL		120	12	Clear (31)*	13250	400	C-8	4 11/16	2 3/8	3200	
			23734	FDN-Q500T3/4	P2/31	120	12	Frosted (26, 31)*	12800	400	C-8	4 11/16	2 3/8	3200	
	T4	Med Pf (P28s)	39135	EGE-Q500CL/P		120	12	Clear (15)*	10450	2000	CC-8	6	3 1/2	2950	
		Med 2-pin (G9.5)	37082	EHC-Q500/5CL		120	6	Clear (15, 29)*	12700	500	CC-8	4	2 3/8	3150	
			37083	EHD-Q500CL/TP		120	6	Clear (15)*	10450	2000	CC-8	4	2 3/8	2950	
		Mini-Cand	47950	EVR-Q500CL/MC		120	6	Clear (15, 19)*	10450	2000	CC-8	3 5/8	2	2950	
	T6	Med Pf (P28s)	11966	BTL-Q500T6/CL/P	T17	120	12	Clear (17)*	11000	500	C-13	5 1/4	2 3/16	3000	
			16465	BTM-Q500T6/4CL/2P		120	12	Clear (17)*	13000	150	C-13	5 1/4	2 3/16	3200	
	T8	Med BiPost (G22)	30373	EGN-Q500T8		120	12	Clear (12)*	13000	150	C-13	5 1/2	2 1/2	3200	
		2-Pin Pf (GX9.5)	30458	FRG-Q500T8	CP82	120	50	Clear (17)*	13000	150	C-13	3 7/16	1 13/16	3200	
			30461	FRF-Q500T8	T18	120	50	Clear (17)*	12000	400	C-13	3 7/16	1 13/16	3050	
	T12	Med Pf (P28s)	39134	EGC-Q500/5CL/P		120	12	Clear (15)*	12700	500	CC-8	6	3 1/2	3150	
525	T3	R7S	20883	EJG/HIR-Q525T2 1/2/4		120	6	Halogen-IR, HORZ (31)*	20600	400	C-8	4 11/16	2 1/2	3250	
575	T6	Med 2-pin (G9.5)	11450	FLK-Q575T6/4CL		115	24	Clear (15)*	16500	300	CC-8	4	2 3/8	3200	
			14327	FLK/LL-Q575T6		115	50	Clear, Long Life (15)*	12800	1500	CC-8	4	2 3/8	2950	
		Special	37129	HPL575		115	12	Clear (15)*	16500	300		4	2 3/8	3200	
			37533	HPL575		120	12	Clear (15)*	16500	300		4	2 3/8	3200	
		Med 2-pin (G9.5)	26807	HP602		115	50	Clear (15)*	14000	300	C-13	4	2 3/8	3200	
			37404	HP603		115	24	Clear (15)*	12000	1500	C-13	4	2 3/8	3200	
600	T5	2-Pin Pf (GX9.5)	30475	FMR-Q600T5		120	24	Clear Long Life (15)*	12600	2000	CC-8	3 7/8	2	3050	
650	PAR36	FERRULE	41668	FAY-Q650PAR36/3D		120	12	Spot (3, 4)*		30		2 7/16		5000	- 25x15
		Scrw Term	41669	FBE-Q650PAR36/5D		120	12	Spot (3, 4)*		30		2 7/16		5000	- 25x15
			41671	FBO-Q650PAR36/5		120	12	Spot (3, 4)*		30		2 7/16		3400	- 25x15
		FERRULE	41672	FCW-Q650PAR36/6		120	12	Flood (3, 4)*		100		2 7/16		3200	- 60x55
			41673	FCX-Q650PAR36/7		120	12	Medium Flood (3, 4)*		100		2 7/16		3200	- 40x30
		Scrw Term	41667	DWE-Q650PAR36/1		120	12	Medium Flood (3, 4)*		100		2 9/16		3200	- 40x30
	T3	R7S	13895	FCM/HIR-Q650T3/4		120	6	Halogen-IR, Clear (31)*	25200	400	C-8	4 11/16	2 3/8	3275	
	T4	RSC R7S	30325	FAD-Q650T4/4CL	P2/6	120	24	Clear	16500	100	CC-8	3 3/16	5/8	3200	
			30343	FBX-Q650T4/4		120	24	Frosted (14, 26)*	16500	100	CC-8	3 3/16	5/8	3200	
	T8	2-Pin Pf (GX9.5)	30481	FRK-Q650T8	CP89	120	50	Clear (17)*	16900	200	C-13	3 7/16	1 13/16	3200	
			30476	FRE-Q650T8	T26	120	50	Clear (17)*	15000	400	C-13	3 7/16	1 13/16	3050	
	G6	2-Pin Pf (GX9.5)	34328	EKD-Q650/3CL/2PP		120	24	Clear (16, 17)*	20000	25	CC-6	2 1/2	1 7/16	3300	
675	T3	R7S	20884	FFT/HIR-Q675T3/4		120	6	Halogen-IR (31)*	26400	400	C-8	6 9/16	2 5/8	3250	
750	T3	R7S	23756	EJG-Q750T3/4CL		120	12	Clear (31)*	20600	400	C-8	4 11/16	2 1/2	3200	
			23755	EMD-Q750T3/4		120	12	Frosted (31)*	19500	400	C-8	4 11/16	2 1/2	3200	
	T6	Med Pf (P28s)	39136	EGF-Q750/4CL/P		120	12	Clear (15)*	20400	500	CC-8	6	3 1/2	3200	
			39137	EGG-Q750CL/P		120	12	Clear (15)*	15750	2000	CC-8	6	3 1/2	3000	
		Med 2-pin (G9.5)	37051	EHF-Q750/4CL		120	6	Clear (15)*	20400	500	CC-8	4	2 3/8	3200	
			43167	EHG-Q750CL/TP		120	6	Clear (15)*	15400	2000	CC-8	4	2 3/8	3000	
	T7	Med Pf (P28s)	11954	BTP-Q750T7/4CL/2P		120	12	Clear (15)*	21000	200	C-13D	4 3/4	2 3/16	3200	
		Med BiPost (G22)	39190	EGR-Q750T7/4CL		120	12	Clear (17)*	21000	200	C-13D	5	2 1/2	3200	
		Med Pf (P28s)	11953	BTN-Q750T7/CL/2P		120	12	(15)*	17600	500	C-13D	4 3/4	3 3/16	3050	
	T8	Med 2-pin (G9.5)	39680	BWM-Q750T7/4CL/TP		120	6	Clear (17)*	21000	200	C-13D	4 1/2	2 3/8	3200	
800	GX9.5		32714	HX185/Q800		120	24	(17)*	19000	300		3 15/16	2 3/16		
1000	PAR64	ExMogEndPr	13226	FGM-Q1000PAR64/3D		120	6	Narrow Spot Dichroic (3)*		200				5200	24x12 13x6
			13233	FFN-Q1000PAR64/1		120	6	Very Narrow Spot, Clear (3)*	11000	800		6		3200	24x10 12x6

To save energy costs, find the bulbs with the light output you need, then choose the one with the lowest watts.

© Means this lamp meets Federal Minimum Efficiency Standards. (*) * All footnote references found at the end of this section.

⚡ Reduced Wattage

☼ High Color Rendering

Stage and Studio Lamps



Watts	Bulb	Base	Product Code	Lamp Description	LIF Code	Volts	Case Qty.	Additional Information	Rated		Filament Design	MOL	LCL	Temp. K	Approx. Beam Spread	
									Initial Lumens	Avg. Life Hours					10%	50%
STAGE/STUDIO QUARTZLINE® TUNGSTEN HALOGEN LAMPS (ARRANGED IN WATTAGE ORDER) (Continued)																
1000	PAR64	ExMogEndPr	13229	FFP-Q1000PAR64/2		120	6	Narrow Spot, Clear (3)*	12000	800		6		3200	26x14	14x7
			13228	FFR-Q1000PAR64/5		120	6	Medium Flood, Clear (3)*	14000	800		6		3200	44x11	28x12
			13227	FFS-Q1000PAR64/6	-	120	6	Wide Flood, Clear (3)*	19000	800		6		3200	71x45	48x24
			13225	FGN-Q1000PAR64/7D	-	120	6	Medium Flood Dichroic (3)*	8200	200		6		5200	43x20	37x11
PS52	Mog (E39)		39582	DKZ/DSE-Q1000PS52/4		120	12	I.F., Scoop Lamp (15, 22)*	28000	750	CC-8	13	9 1/2	3200		
T3	R7S		23788	EJD-Q1000T3/3CL		185	12	Clear (31)*	33600	100	C-8	4 11/16	2 3/4	3350		
			23797	FCM-Q1000T3/4CL	P2/28	120	12	Clear (31)*	28000	400	C-8	4 11/16	2 3/8	3200		
			33280	FFT-Q1000T3/1CL		120	12	Clear (31)*	26400	400	C-8	6 9/16	2 5/8	3200		
			23792	FHM-Q1000T3/4	P2/29	120	12	Frosted (26, 31)*	27300	400	C-8	4 1/4	2 3/8	3200		
T5	R7S		30157	DXW-Q1000T5/4CL		120	24	Clear (27)*	28000	150	CC-8	3 3/4	7/8	3200		
			30374	FBY-Q1000T5/4		120	24	Frosted (26, 27)*	26000	150	CC-8	3 3/4	7/8	3200		
T6	Med Pf (P28s)		38853	EGJ-Q1000/4CL/P		120	12	Clear (15)*	27500	300	CC-8	6	3 1/2	3200		
			38852	EGK-Q1000/4/P		120	12	Frosted (15)*	26500	300	CC-8	6	3 1/2	3200		
			39138	EGM-Q1000CL/P		120	12	Clear (15)*	21500	2000	CC-8	6	3 1/2	3000		
	Med 2-pin (G9.5)		35853	FCV-Q1000/4		120	6	Frosted (15, 20)*	26500	375	CC-8	4	2 3/8	3200		
			35607	FEL-Q1000/4CL		120	6	Clear (15, 20)*	27500	375	CC-8	4	2 3/8	3200		
T7	Med Pf (P28s)		11955	BTR-Q1000T7/4CL/2P		120	12	Clear (15)*	28500	250	C-13D	4 3/4	2 3/16	3200		
	Mog Pf (P40s)		12554	BVT-Q1000T7/CL/MP		120	6	Clear (15)*	24500	500	C-13 D	7 1/4	3 15/16	3050		
			12553	BVV-Q1000T7/4CL/MP		120	6	Clear (15)*	28500	200	C-13D	7 1/4	3 15/16	3200		
	Med 2-pin (G9.5)		39681	BWN-Q1000T7/4CL/TP		120	6	Clear (17)*	28500	250	C-13D	4 1/2	2 3/8	3200		
	Mog BiPost (G38)		42697	CYV-Q1000T7/4CL/BP		120	6	Clear (17)*	28500	200	C-13D	8	5	3200		
	Med BiPost (G22)		39191	EGT-Q1000T7/4CL		120	12	Clear (17)*	28500	250	C-13D	5	2 1/2	3200		
T6	R7S		33760	FER-Q1000T6/4CL		120	6	Clear (15)*	27500	500	CC-8	5 5/8	1 3/16	3200		
1200	PAR64	ExMogEndPr	34812	GFA-Q1200PAR64/5		120	6	Medium Flood, Clear (3)*		400		6		3200	13x24	22x36
			34810	GFB-Q1200PAR64/2		120	6	Narrow Spot, Clear (3)*		400		6		3200	8x10	16x18
			34808	GFC-Q1200PAR64/1		120	6	Very Narrow Spot, Clear (3)*		400		6		3200	8x10	14x16
			34806	GFE-Q1200PAR64/6		120	6	Wide Flood, Clear (3)*		400		6		3200	25x58	34x71
1500	PS52	Mog (E39)	40357	DKX/DSF-Q1500PS52/4		120	12	I.F., Scoop Lamp (15, 22)*	41000	1000	C-8	13		3200		
T4	RSC (R7S)		23841	FDB-Q1500T4/4CL		120	12	Clear (31)*	41200	400	C-8	6 9/16	2 7/16	3200		
			41229	FGT-Q1500T4/4		120	12	Frosted (26, 31)*	40200	400	C-8	6 9/16	2 13/32	3200		
T8	Mog Pf (P40s)		30522	DTA-Q1500T8/4CL		120	6	(17)*	41000	300	C-13D	7 7/8	3 7/16	3200		
T10	Mog BiPost (G38)		37564	CXZ-Q1500T10/4CL		120	6	Clear (17)*	44500	400	C-13	8 1/2	5	3200		
2000	T4	RSC (R7S)	33761	FEY-Q2000T8/4CL		120	6	Clear (4)*	57000	400	CC-8	5 5/8	1	3200		
	T8	Mog BiPost (G38)	39587	BWA-Q2000/4CL/BP		120	6	Clear (23)*	54000	500	CC-8	8 1/4	5	3200		
		Mog (E39)	37086	BWF-Q2000/4CL		120	6	Clear (15)*	54000	500	CC-8	7 1/2	5 1/4	3200		
			30491	BWG-Q2M/T9		120	6	Frosted (15)*	56000	400	CC-8	7 1/2	5 1/4	3200		
	T10	Mog Pf (P40s)	12555	BVW-Q2000T10/4CL/MP		120	6	Clear (15)*	59000	350	C-13	8 15/32	3 15/16	3200		
		Mog BiPost (G38)	36636	CYX-Q2000T10/4CL		120	6	Clear (17)*	59000	350	C-13	8	5	3200		
5000	T20	Mog BiPost (G38)	41736	DPY-Q5000T20/4CL	CP29	120	6	Clear (9)*	143000	500	C-13	11	6 1/2	3200		
10000	T24	Mog BiPost (G38)	18305	DTY-Q10M/T24/4CL		120	4	Clear (9)*	290000	300	C-13	15 3/4	10	3200		



Watts	Bulb	Base	Product Code	Lamp Description	LIF Code	Case Volts	Case Qty.	Additional Information	Rated		Filament Design	MOL	LCL	Temp. K	Approx. Beam Spread		
									Initial Lumens	Avg. Life Hours					10%	50%	
STAGE/STUDIO QUARTZLINE® TUNGSTEN HALOGEN HIGH VOLTAGE LAMPS (ARRANGED IN WATTAGE ORDER)																	
300	T8	2-Pin Pf (GX9.5)	30456	FSL-Q300T8		230	50	(17)*	6900	150	C-13	3 7/16	1 13/16	3200			
500	T8	Med Pf (P28s)	30535	FKF-Q500T6/CL	T17	230	12	(17)*	9500	750	C-13	5 1/4	3 3/16	2950			
		2-Pin Pf (GX9.5)	30459	FRH-Q500T8		230	50	(17)*	12500	150	C-13	3 7/16	1 13/16	3200			
			30462	GCV-Q500T8		230	50	(17)*	11000	400	C-13	3 7/16	1 13/16	3050			
575	T6	Med 2-pin (G9.5)	35376	GKV-Q575T6/4CL		230	50		14000	250	C-13	4	2 3/8	3200			
		Special	37128	HPL575		230	12		15000	300		4	2 3/8	3200			
625	T3	R7S	19697	Q625T3/4CL	P2/10	230	12	(4)*	16900	300	C-8	7 7/16	4 23/32	3200			
			19698	Q625T3/4CL	P2/10	240	12	(4)*	16900	300	C-8	7 7/16	4 23/32	3200			
650	T6	Med 2-pin (G9.5)	30488	FKR-Q650T6/CL		230	24	(15)*	15000	300	CC-8	4	2 3/8	3100			
		T8	Med Pf (P28s)	30541	FKB-Q650T8	T13	230	12	Clear (9)*	13500	750	C-13	5 1/8	2 3/16	3000		
		Med BiPost (G22)	20320	FKH-Q650T8/4CL	CP39	230	12	(17)*	16900	200	C-13	5 1/2	2 1/2	3200			
		Med Pf (P28s)	20323	FKM-Q650T8/4CL	CP51	230	12	(17)*	16900	200	C-13	5 1/4	3 3/16	3200			
		2-Pin Pf (GX9.5)	30482	FRL-Q650T8		230	50	(17)*	16250	150	C-13	3 7/16	1 13/16	3200			
			20315	Q650T8/4CL	CP23	230	12	(12, 17)*	16900	200	C-13	4 3/8	2 3/16	3200			
800	T3	R7S	23760	EME-Q800T3/4CL	P2/11	230	12	Clear (4, 31)*	22000	150	C-8	4 5/8	2 13/16	3200			
			23761	EMF-Q800T3/4	P2/11	240	12	Frosted (4)*	21400	150	C-8	4 11/16	2 13/16	3200			
1000	PAR64	ExMogEndPr	19909	EXC-Q1M/PAR64	CP60	220	6	(3)*		300		6		3200	20x17	12x6	
			19910	EXC-Q1M/PAR64	CP60	240	6	(3)*		300		6		3200	20x17	12x6	
			19911	EXD-Q1M/PAR64	CP61	220	6	(3)*		300		6		3200	23x20	13x10	
			19912	EXD-Q1M/PAR64	CP61	240	6	(3)*		300		6		3200	23x20	13x10	
			19913	EXE-Q1M/PAR64	CP62	220	6	(3)*		300		6		3200	39x24	25x14	
			19914	EXE-Q1M/PAR64	CP62	240	6	(3)*		300		6		3200	39x24	25x14	
	T3	R7S		20249	EKM-Q1M/T3/4CL	P2/7	230	12	(4)*	28000	300	C-8	7 7/16	4 23/32	3200		
				20253	EKM-Q1M/T3/4CL	P2/7	240	12	(4)*	28000	300	C-8	7 7/16	4 23/32	3200		
	T6		Med Pf (P28s)	30533	EWE-Q1000T6/CL		220	12	(17)*	26500	250	CC-8	6	3 1/2	3200		
			Med 2-pin (G9.5)	31839	FEP-Q1000T6/4CL	CP77	230	50	(15)*	25000	300	CC-8	4	2 3/8	3200		
T8		Med BiPost (G22)	20285	FKJ-Q1M/T8/4CL	CP40	230	12	(17)*	26500	250	C-13	5 1/2	2 1/2	3200			
		Med Pf (P28s)	20287	FKN-Q1M/T8/4CL	CP52	230	12	(17)*	26500	250	C-13	5	3 3/16	3200			
		2-Pin Pf (GX9.5)	20281	Q1000T8/4CL	CP24	230	24	(17)*	26500	250	C-13	4 3/8	2 3/16	3200			
T11		2-Pin Pf (GX9.5)	30434	Q1000T8/CL	T11	230	24		23000	750	C13	4 3/8	2 3/16	3050			
		GY9.5	30434	Q1000T8/CL	T11	230	24	(17)*	23000	750	C-13	4 3/8	2 3/16	3050			
		2-Pin Pf (GX9.5)	30439	FVA-Q1000T11	CP70	230	24	(17)*	25000	200	C-13D	4 3/8	2 3/16	3200			
1250	T3	R7S	19695	Q1250T3/4CL	P2/12	230	12	(4)*	35000	300	C-8	7 7/16	4 23/32	3200			
			19696	Q1250T3/4CL	P2/12	240	12	(4)*	35000	300	C-8	7 7/16	4 23/32	3200			
2000	T8	R7S	35338	FEX-Q2MT8/4CL	P2/27	230	12	(4)*	50000	300	CC-8	5 5/8	1 7/16	3200			
			T10	Mog BiPost (G38)	31844	FKK-Q2MT10/4CL	CP41	230	12	(17)*	54000	400	C-13	8 1/2	5	3200	
		2-Pin Pf (GX9.5)	20309	FTM-Q2000T10/4CL	CP43	230	12	(17)*	54000	400	C-13	5 11/16	2 3/4	3200			
		Mog Pf (P40s)	20311	Q2000T10/4CL	CP53	230	12	(17)*	54000	400	C-13	7 7/8	3 3/16	3200			
5000	T10	Mog BiPost (G38)	30505	Q5000T20	CP29	220	12	(17)*	135000	500	C-13	11	6 1/2	3200			



ANSI Code	Product Code	Lamp Description	Volts
STAGE AND STUDIO ANSI CODES			
BTL	11966	BTL-Q500T6/CL/P	120
BTM	16465	BTM-Q500T6/4CL/2P	120
BTN	11953	BTN-Q750T7/CL/2P	120
BTP	11954	BTP-Q750T7/4CL/2P	120
BTR	11955	BTR-Q1000T7/4CL/2P	120
BVT	12554	BVT-Q1000T7/CL/MP	120
BVV	12553	BVV-Q1000T7/4CL/MP	120
BVW	12555	BVW-Q2000T10/4CL/MP	120
BWA	39587	BWA-Q2000/4CL/BP	120
BWF	37086	BWF-Q2000/4CL	120
BWG	30491	BWG-Q2M/T9	120
BWM	39680	BWM-Q750T7/4CL/TP	120
BWN	39681	BWN-Q1000T7/4CL/TP	120
CWZ	30526	CWZ-Q1500/T12	120
CXZ	37564	CXZ-Q1500T10/4CL	120
CYV	42697	CYV-Q1000T7/4CL/BP	120
CYX	36636	CYX-Q2000T10/4CL	120
DEB	21799	500T12/8	120
DKX	40357	DKX/DSF-Q1500PS52/4	120
DKZ	39582	DKZ/DSE-Q1000PS52/4	120
DMX	29802	500T20P-DMX	115/0
DNS	21795	500T12/9	120
DNW	21887	500T20/64	120
DPW	29964	1M/T20P-DPW	115/0
DPY	41736	DPY-Q5000T20/4CL	120
DTA	30522	DTA-Q1500T8/4CL	120
DTJ	30004	1500T20/39-DTJ	115/0
DTY	18305	DTY-Q10M/T24/4CL	120
DVS	23733	Q500T3/CL-DVS	130
DWC	19797	150R/FL	120
DWE	41667	DWE-Q650PAR36/1	120
DWT	23800	Q1000T6/CL-DWT	120
DXW	30157	DXW-Q1000T5/4CL	120
DYA	30362	DYA-Q1000T5/1CL	120
DYG	37427	DYG-Q250/4CL/2PP	30
EGC	39134	EGC-Q500/5CL/P	120
EGE	39135	EGE-Q500CL/P	120
EGF	39136	EGF-Q750/4CL/P	120
EGG	39137	EGG-Q750CL/P	120
EGJ	38853	EGJ-Q1000/4CL/P	120
EGK	38852	EGK-Q1000/4/P	120
EGM	39138	EGM-Q1000CL/P	120
EGN	30373	EGN-Q500T8	120
EGR	39190	EGR-Q750T7/4CL	120
EGT	39191	EGT-Q1000T7/4CL	120
EHC	37082	EHC-Q500/5CL	120
EHD	37083	EHD-Q500CL/TP	120
EHF	37051	EHF-Q750/4CL	120
EHG	43167	EHG-Q750CL/TP	120
EHM	43703	Q300T3/CL-EHM	120
EHP	43705	Q300T4/CL-EHP	120
EHR	43708	Q400T4/CL-EHR	120
EHT	43699	Q250CL/MC-EHT	120
EHZ	43704	Q300T3-EHZ	120
EJD	23788	EJD-Q1000T3/3CL	185
EJG	23756	EJG-Q750T3/4CL	120
EJG	20883	EJG/HIR-Q525T2 ¹ / ₂ /4	120

ANSI Code	Product Code	Lamp Description	Volts
STAGE AND STUDIO ANSI CODES			
EKB	33934	EKB-Q420/4CL/2PP	120
EKD	34328	EKD-Q650/3CL/2PP	120
EKM	20249	EKM-Q1M/T3/4CL/P2/7	230
EKM	20253	EKM-Q1M/T3/4CL/P2/7	240
EMD	23755	EMD-Q750T3/4	120
EME	23760	EME-Q800T3/4CL	230
EMF	23761	EMF-Q800T3/4	240
ESL	44383	Q150CL/MC/2V-ESL	120
ESM	43695	Q250MC-ESM	120
ESN	44385	Q100CL/MC/2V-ESN	120
ESP	44384	Q150CL/DC/2V-ESP	120
ESR	44386	Q100CL/DC/2V-ESR	120
ESS	43697	Q250CL/DC-ESS	120
ETB	43701	Q250DC-ETB	120
ETC	43693	Q150CL/DC-ETC	120
ETD	44657	Q100DC/2V-ETD	120
ETE	44656	Q100MC/2V-ETE	120
ETF	44653	Q150DC-ETF	120
EXD	19912	EXD-Q1M/PAR64/CP61	240
ETG	43694	Q150CL/MC-ETG	120
ETH	44654	Q150MC-ETH	120
EVR	47950	EVR-Q500CL/MC	120
EWE	30533	EWE-Q1000T6/CL	230
EXC	19909	EXC-Q1M/PAR64/CP60	220
EXC	19910	EXC-Q1M/PAR64/CP60	240
EXD	19911	EXD-Q1M/PAR64/CP61	220
EXE	19913	EXE-Q1M/PAR64/CP62	220
EXE	19914	EXE-Q1M/PAR64/CP62	240
EXG	19915	EXG-Q1M/PAR64	220
EXG	19918	EXG-Q1M/PAR64	240
FAD	30325	FAD-Q650T4/4CL	120
FAY	41668	FAY-Q650PAR36/3D	120
FBE	41669	FBE-Q650PAR36/5D	120
FBO	41671	FBO-Q650PAR36/5	120
FBX	30343	FBX-Q650T4/4	120
FBY	30374	FBY-Q1000T5/4	120
FCL	23731	Q500T3/CL-FCL	120
FCM	13895	FCM/HIR-Q650T3/4	120
FCM	23797	FCM-Q1000T3/4CL	120
FCV	35853	FCV-Q1000/4	120
FCW	41672	FCW-Q650PAR36/6	120
FCX	41673	FCX-Q650PAR36/7	120
FDB	23841	FDB-Q1500T4/4CL	120
FDG	23735	FDG-Q500T3/4CL	120
FDG	20881	FDG/HIR-Q350T2/4CL	120
FDN	23734	FDN-Q500T3/4	120
FEL	35607	FEL-Q1000/4CL	120
FEP	31839	FEP-Q1000T6/4CL	230
FER	33760	FER-Q1000T6/4CL	120
FEV	14119	FEV-Q200/CL/DC	120
FEX	20297	FEX-Q2M/T8/4CL	230
FEY	33761	FEY-Q2000T8/4CL	120
FFN	13233	FFN-Q1000PAR64/1	120
FFP	13229	FFP-Q1000PAR64/2	120
FFR	13228	FFR-Q1000PAR64/5	120
FFS	13227	FFS-Q1000PAR64/6	120
FFT	33280	FFT-Q1000T3/1CL	120



ANSI Code	Product Code	Lamp Description	Volts
STAGE AND STUDIO ANSI CODES			
FFT	20884	FFT/HIR-Q675T3/4	120
FGM	13226	FGM-Q1000PAR64/3D	120
FGN	13225	FGN-Q1000PAR64/7D	120
FGT	41229	FGT-Q1500T4/4	120
FHM	23792	FHM-Q1000T3/4	120
FKB	30541	FKB-Q650T8	230
FKE	30531	FKE-Q1000T11	230
FKF	30535	FKF-Q500T6/CL	230
FKH	20320	FKH-Q650T8/4CL/CP39	230
FKJ	20285	FKJ-Q1M/T8/4CL/CP40	230
FKM	20323	FKM-Q650T8/4CL/CP51	230
FKN	20287	FKN-Q1M/T8/4CL/CP52	230
FKR	30488	FKR-Q650T6/CL	230
FKW	30455	FKW-Q300T8	120
FLK	11450	FLK-Q575T6/4CL	115
FMR	30475	FMR-Q600T5	120
FRE	30476	FRE-Q650T8	120
FRF	30461	FRF-Q500T8	120
FRG	30458	FRG-Q500T8	120
FRH	30459	FRH-Q500T8	230
FRK	30481	FRK-Q650T8	120
FRL	30482	FRL-Q650T8	230
FSL	30456	FSL-Q300T8	230
FVA	30439	FVA-Q1000T11	230
FWP	30436	FWP-Q1000T11	230
GCT	30479	GCT-Q650T8	230
GCV	30462	GCV-Q500T8	230

FOOTNOTES

- # Footnote
- Hemispherical shield in front of filament masking all direct light.
 - If lamp is cracked or broken, replace immediately. It may continue to operate, but the inner bulb is pressurized and could shatter unexpectedly. Dispose of with care.
 - Although made of heat-resistant glass, the bulb and lens should be protected from moisture or breakage may result. The lens or bulb may break during usage under certain other conditions beyond the control of the manufacturer. Therefore, screening techniques are recommended, where appropriate, to protect people and surroundings from possible hot fragments. If lamp is cracked or broken, replace immediately. It may continue to operate, but the inner bulb is pressurized and could shatter unexpectedly.
 - Operate at or near horizontal.
 - Although this lamp is made of heat-resistant glass, the bulb and lens should be protected from moisture or breakage may result. To protect persons against risk of breakage, use a protective screen external to the lamp.
 - To protect persons against risk of breakage, use a protective screen external to lamp.
 - Use only in fixture designed for Cool Beam PAR lamps.
 - Burning position vertical base down $\pm 30^\circ$.
 - Burning position vertical base down $\pm 45^\circ$.
 - Has blackening protector grid.
 - Non-stock item available to special order.
 - 21mm max bulb.
 - Staggered filament.
 - Frosted bulb.
 - Universal operating position.
 - Ultra-violet absorbing bulb.
 - BOTH operating position.
 - Top end of bulb is opaque-coated to absorb upward light.
 - Life depends on service conditions; for use only in equipment specially designed to maintain bulb and base temperatures within safe limits.
 - To avoid possible overheating, this lamp is not recommended for use without force-cooling in deep-bowled fixtures.
 - Blue glass bulb; apparent color temperature may vary from lamp to lamp.
 - Silica coated.
 - Burn BOTH but avoid horizontal burning with support spine beneath filament to prevent premature arcing.
 - 100V rating available to special order.
 - 15mm max bulb.
 - Apparent lighted length slightly longer than similar clear lamp.
 - No filament support rod.
 - Hot (instant) restrike; other lamps require 10-minute pause before restrike.
 - Low noise construction to minimize generation of audible noise when operated on A.C. circuits.
 - Operate base down within 30° of vertical. Any tilt should be in direction in which the filament plane faces.
 - Burning position, horizontal $\pm 4^\circ$.





LAMPS

Miniature Lamps	7-5
Sealed Beam Lamps	7-14



LAMP LOCATOR

The lamps listed here are not to scale. To determine the diameter of a bulb in inches, multiply the bulb number by one-eighth. For example T-2 means approximately $\frac{2}{8}$ " or $\frac{1}{4}$ " diameter.

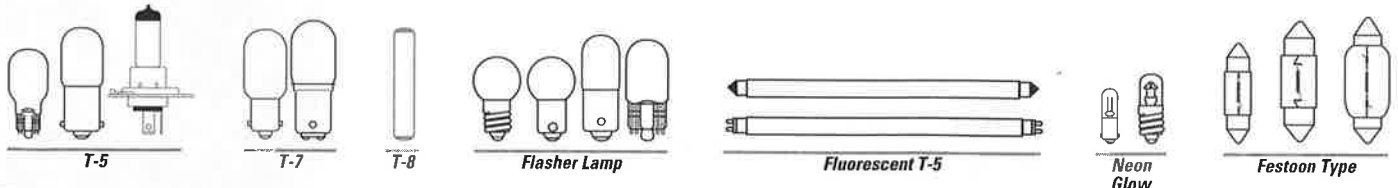
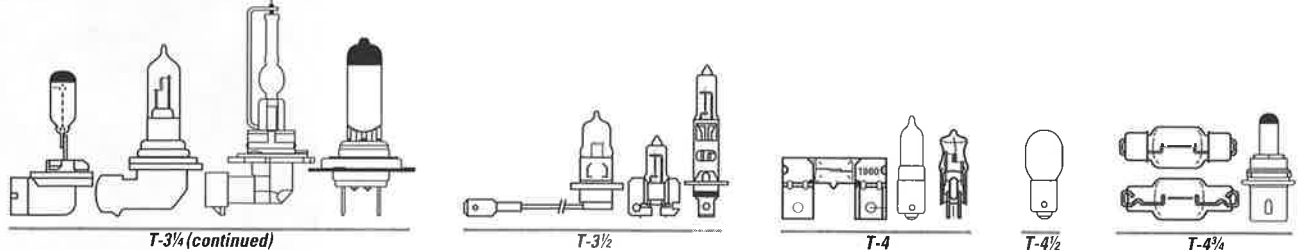
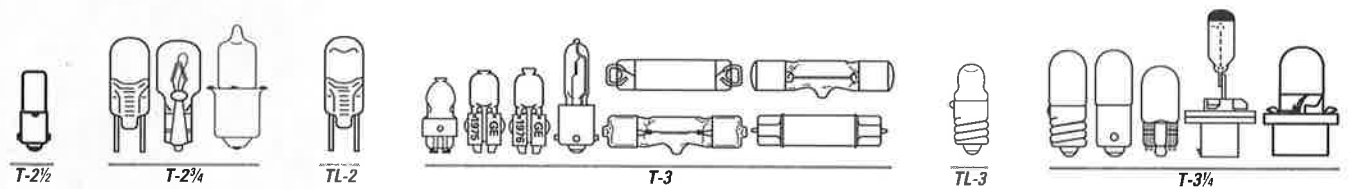
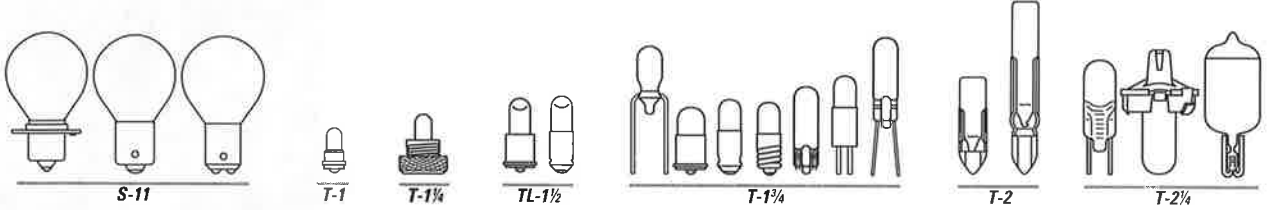
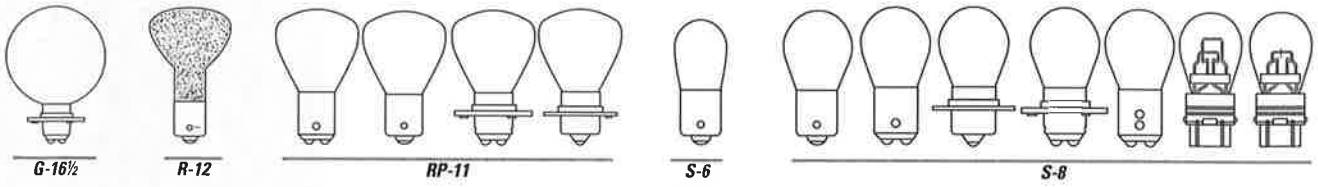
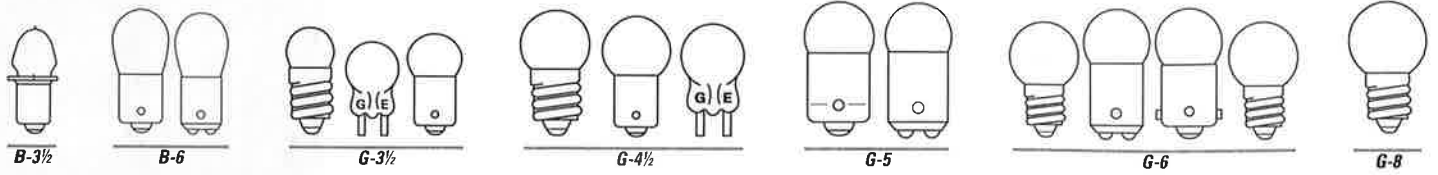



MINIATURE BASES

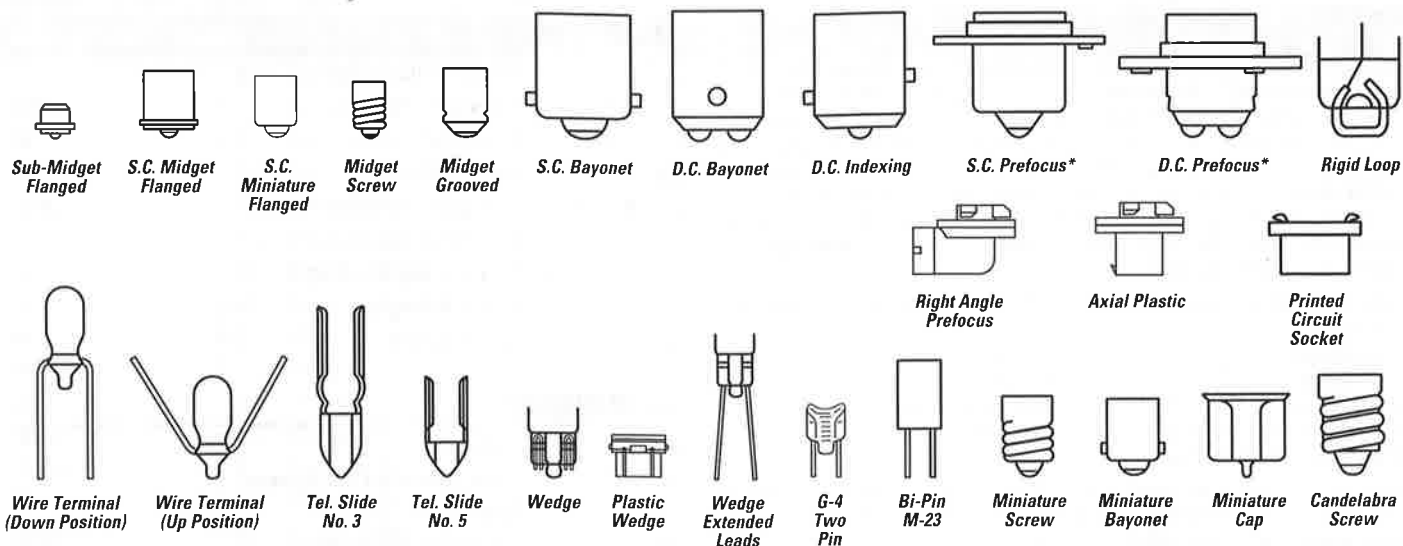

SEALED BEAM LAMPS

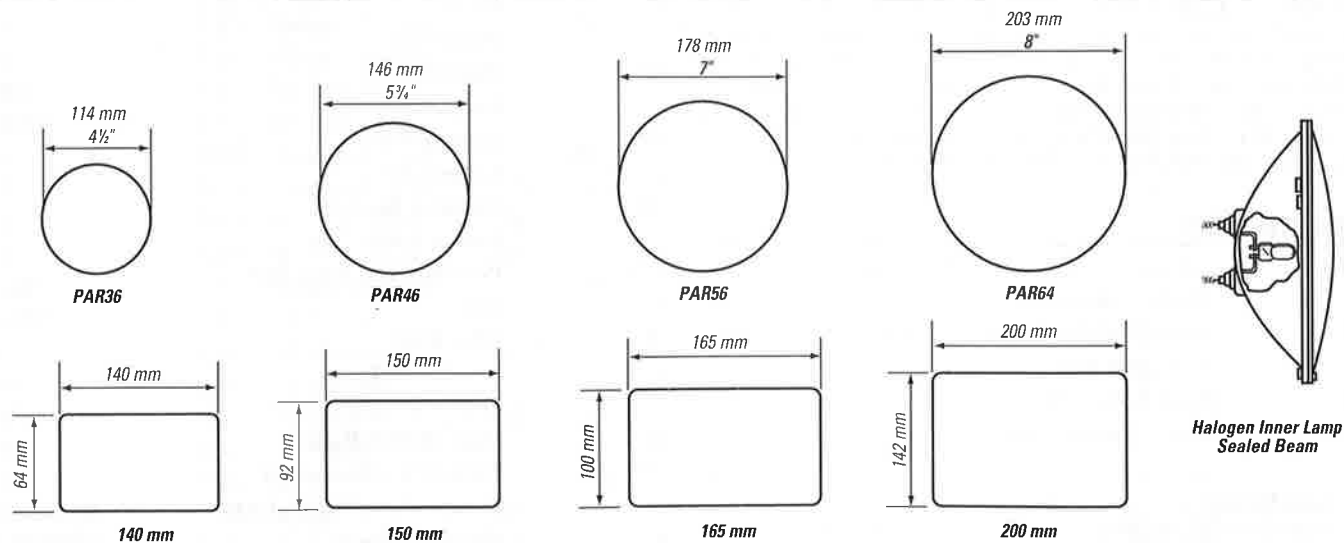

SEALED BEAM BASES

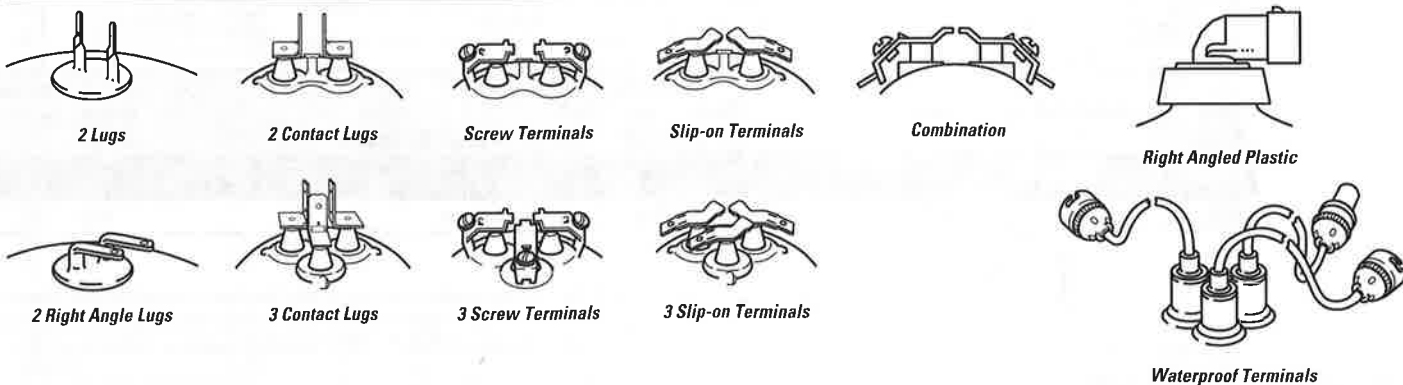

* S.C. and D.C. Prefocused Base Lamps: The letter "A" following the base type designates that the distance from the bottom of the collar to the bottom of the base contact is 19/32". For "B" bases this distance is 9/16". The few lamps identified by the letter "S" in the base column are special in that the collar location and/or the orientation of the contacts differ from the above.



INTRODUCTION

GE MINIATURE AND SEALED BEAM PRODUCT ORDERING INFORMATION

GE Miniature and Sealed Beam Lamps are designed for those applications requiring specific bulb size, base, and voltage. These lamps are operated on vehicles (cars, trucks, boats, aircraft, tractors) or in special applications utilizing low voltage sources. Most lamps are designated by common ANSI (American National Standards Institute) lamp numbers and lamps in this section are arranged in numerical order. To assist you in identifying lamps, drawings (not to scale) are provided, along with descriptions of bulb and base sizes.

Specific market segments covered in this section are products used in:

Aircraft	Garden/Outdoor
Automotive	Indicator
Agriculture	Marine
CIM/Tractor	Medical/Instruments
Emergency Building Lighting	Telephone
Flashlight/Hand Lanterns	Toys/Entertainment

For additional specifications and cross reference identification refer to the Miniature and Sealed Beam Catalog #82780 (208-71048) which can be obtained through your GE Sales Office.

FINDING AND ORDERING A LAMP

Most Miniature Lamps have a number on the base or bulb. Generally it will match the lamp number in this catalog, which is sorted in numeric order (prefixes last). The catalogue is divided into Miniature and Sealed Beam sections. Sealed Beam lamps start on page 13. Often the first prefix is another lamp manufacturer's identification and can be ignored. You can verify the lamp using the drawings provided. Order codes for Blister, Unit, and Bulk Pack for OEM's are provided.

ABBREVIATIONS

CIM	Construction & Industrial Machinery
D.C.	Double Contact Base
PAR	Parabolic Reflector in Sealed Beams
Pf.	Prefocused Base
S.C.	Single Contact Base
2D, 3D	Battery Number/Type

LAMP PREFIXES

DE	Double-Ended Festoon Lamp
GE	GE non-ANSI type
H	Halogen
KPR	Krypton Prefocus
P, C, R, T, W, H	European Designations
PC	Printed Circuit Socket
PR	Prefocus (eg. Flashlight)
Q	Quartz Halogen
SE	Single Ended

LAMP SUFFIXES

AF	All Frosted
AS15	Aged/Selected Candlepower
B	Blue
CW	Cool White Fluorescent
D	Lead Wire Down
E, E1	Extended Lead Wire
G	Green
HD	Heavy Duty
HO	High Output
K	Unique Base
KR	Krypton Filled
LL, XL	Longer Life
MB	Miniature Bayonet
NA	Natural Amber Glass
PSB	Pilot Indicator/Short Base
R	Red
SB	Silver Bowl
TY	Deviation in Lamp
U	Lead Wire Up
W	Watts (R5W=5 Watts)
WW	Warm White Fluorescent
X	Deviation from Similar Lamp
-1	Slip-on Terminals

Lamp Number:

In nearly all cases lamps are marked with a General Electric Trade Number recorded with the ANSI. See glossary of prefixes and suffixes above.

Bulb Size:

The prefix letter describes the shape and the number is the approximate bulb diameter.

Halogen (H):

Indicates if the bulb is a halogen lamp.

Lamp Base:

Base types are depicted on the previous pages for both Miniature and Sealed Beam.

Product Code:

Use this code when ordering to ensure that you receive the exact product you require.

Primary Application:

Current uses of the lamp in general. Lamps are used in other applications than listed.

Design Volts:

Voltage at which the lamp is designed to provide the amperes, candlepower, and laboratory life characteristics.

Maximum Length:

In inches from the top of the bulb to the bottom of the base.

Lamp Number	Halogen (H)	Bulb Size	Lamp Base	Product Code			Primary Application	Design Volts	Maximum Length in.
				Blister Pack	Unit Pack	Bulk Pack			
48C2		T-2			29041		Telephone	48.0	1.69

MINIATURE LAMPS

T - 2

Identifies the shape (S=Pear, T=Tubular, G=Globe, R=Reflector)

Identifies the approximate bulb diameter in eighths of an inch.

T-2 is Tubular approximately 2/8" in diameter. Sealed Beam bulb sizes are also in eighths of an inch if round (PAR). PAR36 is 36/8" or 4 1/2" in diameter. If the Sealed Beam is rectangular in shape the longest side is measured in millimeters. A 165mm Sealed Beam measures 6 1/2" (165mm) across the top.

Miniature & Sealed Beam Lamps



Lamp Number	Halogen Bulb Size (in.)	Lamp Base	Product Code			Primary Application	Maximum	
			Blister Pack	Unit Pack	Bulk Pack		Design Volts	Length in.
MINIATURE LAMPS								
6	S-8	D.C. Bayonet		25299		Sewing Machine	6.4	2.00
6PSB	T-2	Tel. Slide #5		12756		Telephone	6.0	1.11
10	G-3 1/2	Miniature Two Pin		25312		Indicator	2.5	0.94
12	G-3 1/2	Miniature Two Pin		25319	25321	Radio	6.3	0.94
12PSB	T-2	Tel. Slide #5		12760		Telephone	12.0	1.11
13	G-3 1/2	Miniature Screw		25331		Flashlight-3D	3.7	0.94
14	G-3 1/2	Miniature Screw	12689	25354		Flashlight-2D	2.47	0.94
15	G-4 1/2	Miniature Two Pin		25371		Indicator	7.0	1.07
19	G-3 1/2	Miniature Two Pin		25377	25379	Toy Train	14.4	0.94
24	T-2 3/4	Wedge	12325	17853		Auto	14.0	0.91
24E2	T-2	Tel. Slide #3		29001		Telephone	24.0	1.69
24NA	T-2 3/4	Wedge	12316			Auto-Natural Amber Bulb	14.0	0.91
24PSB	T-2	Tel. Slide #5		12071		Telephone	24.0	1.11
27	G-4 1/2	Miniature Screw		25388		Hand Lantern-4F	4.9	1.07
28MB	T-2 1/2	Miniature Bayonet		12761		Telephone	28.0	1.19
28PSB	T-2	Tel. Slide #5		12072		Telephone	28.0	1.11
37	T-1 3/4	Wedge	26480	39220	13689	Auto	14.0	0.80
43	T-3 1/4	Miniature Bayonet		25442		Indicator	2.5	1.19
44	T-3 1/4	Miniature Bayonet		25450	25466	Pin Ball	6.3	1.19
47	T-3 1/4	Miniature Bayonet		25485		Pin Ball	6.3	1.19
48C2	T-2	Tel. Slide #3		29041		Telephone	48.0	1.69
48PSB	T-2	Tel. Slide #5		12075		Telephone	48.0	1.11
51	G-3 1/2	Miniature Bayonet		25529		Indicator	7.5	0.94
53	G-3 1/2	Miniature Bayonet	12333	25550	25552	Auto	14.4	0.94
55	G-4 1/2	Miniature Bayonet	25578	25576		Instrument	7.0	1.07
57	G-4 1/2	Miniature Bayonet	23218	25591	25593	Auto	14.0	1.07
60MB	T-2 1/2	Miniature Bayonet		12076		Indicator	60.0	1.19
60PSB	T-2	Tel. Slide #5		12077		Indicator	60.0	1.11
63	G-6	S.C. Bayonet	12321		25630	Coin Machine	7.0	1.44
64	G-6	D.C. Bayonet		25643		Marine	7.0	1.44
67	G-6	S.C. Bayonet	12324	25652	25654	Auto	13.5	1.44
68	G-6	D.C. Bayonet		25692	25694	Marine	13.5	1.44
70	T-1 3/4	Wedge		43606	43607	Auto	14.0	0.80
73	T-1 3/4	Wedge	23015	39218	39219	Auto	14.0	0.80
74	T-1 3/4	Wedge	21029	38457	38458	Auto	14.0	0.80
81	G-6	S.C. Bayonet		25736		Aircraft/Coin Machine	6.5	1.44
82	G-6	D.C. Bayonet		25751		Marine	6.5	1.44
85	T-1 3/4	Wedge		40969		Indicator	28.0	0.80
86	T-1 3/4	Wedge		40967	40968	Indicator	6.3	0.80
88	S-8	D.C. Bayonet		25772		Indicator	6.8	2.00
89	G-6	S.C. Bayonet	12363	25778	18618	Auto	13.0	1.44
90	G-6	D.C. Bayonet	12364	25794	25796	Auto/Marine	13.0	1.44
93	S-8	S.C. Bayonet	23217	25811	25813	Auto	12.8	2.00
94	S-8	D.C. Bayonet		25829	25831	Marine	12.8	2.00
97	G-6	S.C. Bayonet	12322	25836	25838	Auto	13.5	1.44
98	G-6	S.C. Bayonet		16287	16286	Auto	13.0	1.44
105	B-6	S.C. Bayonet		36147	36148	Auto	12.8	1.75
112	TL-3	Miniature Screw		25848		Flashlight-1AA	1.2	0.93
120MB	T-2 1/2	Miniature Bayonet		12078		Indicator	120.0	1.19



Lamp Number	Halogen (*)	Bulb Size	Lamp Base	Product Code			Primary Application	Design Volts	Maximum Length in.
				Blister Pack	Unit Pack	Bulk Pack			
MINIATURE LAMPS (Continued)									
120PSB		T-2	Tel. Slide #5		12080		Indicator	120.0	1.11
147		T-3/4	Wedge		25916	25917	Indicator	7.0	1.06
149		T-3/4	Wedge			15731	Emergency Lighting	6.15	1.06
157		G-6	Miniature Screw		25927		Medical	5.8	1.22
158		T-3/4	Wedge		25931	25933	Auto	14.0	1.06
161		T-3/4	Wedge	23016	25956	25949	Auto	14.0	1.06
168		T-3/4	Wedge	12327	25962	32668	Auto	14.0	1.06
193		T-3/4	Wedge		19553	19852	Truck	14.0	1.06
193E		T-3/4	Wedge, Extended Leads			19921	Truck	14.0	1.06
193E-1		T-3/4	Wedge, Extended Leads			14968	Truck	14.0	1.06
194		T-3/4	Wedge	12328	25965	25966	Auto	14.0	1.06
194B		T-3/4	Wedge	12356			Auto-Blue Coated	14.0	1.06
194G		T-3/4	Wedge	12357			Auto-Green Coated	14.0	1.06
194NA		T-3/4	Wedge	12319	44859	44860	Auto-Natural Amber Bulb	14.0	1.06
194R		T-3/4	Wedge	12355		21618	Auto-Red Coated	14.0	1.06
194XL		T-3/4	Wedge	25832			Auto-Long Life	14.0	1.06
198		S-8	D.C. Index		37983	37984	Truck-Stop/Tail	12.8/14.0	2.00
199		S-8	S.C. Bayonet		37985	37986	Truck-Stop	12.8	2.00
210		B-6	D.C. Bayonet		25988		Instrument	6.5	1.75
211-2		T-3	Miniature Cap	12673	39224	39225	Auto Interior	12.8	1.72
212-2		T-3	Miniature Cap	23220		39223	Auto Interior	13.5	1.72
214-2		T-3	Miniature Cap	40135	39356	39357	Auto Interior	13.5	1.72
222		TL-3	Miniature Screw	12692	26008		Flashlight-Lens-2AA	2.25	0.93
238		T-3/4	Miniature Bayonet		26052		Indicator	6.3	1.19
243		TL-3	Miniature Screw		26063		Flashlight-Lens-2C	2.33	0.93
245		G-3/2	Miniature Screw		26070		Flashlight-2D	2.46	0.94
251		T-1 3/4	S.C. Midget Flanged		28464		Indicator	2.47	0.63
252		TL-1 1/2	S.C. Midget Flanged		28466		Instrument-Lens	2.5	0.69
253X		TL-1 1/2	Midget Grooved		28470		Instrument-Lens	2.5	0.69
257		G-4 1/2	Miniature Bayonet		26088		Toy Train-Flasher Lamp	14.0	1.07
258		G-4 1/2	Miniature Screw		26095		Toy Train-Flasher Lamp	14.0	1.07
259		T-3/4	Wedge		26099		Radio	6.3	1.06
265		G-3/4	Miniature Bayonet		44719		Indicator	28.0	0.94
267		T-3/4	Miniature Bayonet		42758	42759	Indicator-Flasher	6.3	1.19
293		G-4 1/2	Miniature Bayonet		32688		Radio	14.0	1.07
301		G-5	S.C. Bayonet		26112		Aircraft	28.0	1.25
302		G-5	D.C. Bayonet		26120		Aircraft	28.0	1.25
303		G-6	S.C. Bayonet		26127		Aircraft	28.0	1.44
304		G-6	D.C. Bayonet		26136		Aircraft	28.0	1.44
305		S-8	S.C. Bayonet		26143		Aircraft	28.0	2.00
305AF		S-8	S.C. Bayonet		26145		Aircraft-Frosted Bulb	28.0	2.00
306		S-8	D.C. Bayonet		26152		Aircraft	28.0	2.00
307		S-8	S.C. Bayonet		26157		Aircraft	28.0	2.00
307AF		S-8	S.C. Bayonet		26161		Aircraft-Frosted Bulb	28.0	2.00
307R		S-8	S.C. Bayonet		26163		Aircraft-Red Coated	28.0	2.00
307SB		S-8	S.C. Bayonet		26166		Aircraft-Silver Bowl	28.0	2.00
308		S-8	D.C. Bayonet		26168		Aircraft	28.0	2.00
308AF		S-8	D.C. Bayonet		26171		Aircraft-Frosted Bulb	28.0	2.00
309		S-11	S.C. Bayonet		26175		Aircraft	28.0	2.38



Lamp Number	Halogen Bulb Size (in.)	Lamp Base	Product Code			Primary Application	Design Volts	Maximum Length in.
			Blister Pack	Unit Pack	Bulk Pack			
MINIATURE LAMPS (Continued)								
310	S-11	D.C. Bayonet		26183		Aircraft	28.0	2.38
311	S-11	S.C. Bayonet		26191		Aircraft	28.0	2.38
313	T-3/4	Miniature Bayonet		26212	26214	Aircraft	28.0	1.19
315	S-8	S.C. Bayonet		26238		Aircraft	28.0	2.00
316	T-3/4	Miniature Bayonet		26243		Aircraft	6.0	1.19
327	T-1 3/4	S.C. Midget Flanged		28519		Aircraft	28.0	0.63
327R	T-1 3/4	S.C. Midget Flanged		28529		Aircraft-Red Coated	28.0	0.63
328	T-1 3/4	S.C. Midget Flanged		28546		Aircraft	6.0	0.63
330	T-1 3/4	S.C. Midget Flanged		28567		Aircraft	14.0	0.63
334	T-1 3/4	Midget Grooved		28588		Aircraft	28.0	0.63
335	T-1 3/4	Midget Screw		28601		Indicator	28.0	0.63
356	G-3 1/2	Miniature Bayonet		26255	26257	Aircraft	28.0	0.94
370	T-1 3/4	S.C. Midget Flanged		28641		Indicator	18.0	0.63
381	T-1 3/4	S.C. Midget Flanged		28653		Indicator	6.3	0.63
382	T-1 3/4	S.C. Midget Flanged		28657		Indicator	14.0	0.63
385	T-1 3/4	S.C. Midget Flanged		28660		Indicator	28.0	0.63
386	T-1 3/4	Midget Grooved		28662		Indicator	14.0	0.63
387	T-1 3/4	S.C. Midget Flanged		28664		Indicator	28.0	0.63
388	T-1 3/4	Midget Grooved		28672		Indicator	28.0	0.63
394	T-1 3/4	S.C. Midget Flanged		28675		Indicator	12.0	0.63
400	T-3/4	Wedge		38918		Aircraft	28.0	1.06
407	G-4 1/2	Miniature Screw		26324	26326	Hand Lantern-Flasher-4F	4.9	1.07
425	G-4 1/2	Miniature Screw		26354	26356	Hand Lantern-4F	5.0	1.07
455	G-4 1/2	Miniature Bayonet		26436		Indicator-Flasher	6.5	1.07
456	G-4 1/2	Miniature Bayonet		26441	26442	Instrument	28.0	1.07
464	T-3/4	Wedge		39645	39646	Aircraft	28.0	1.06
502	G-4 1/2	Miniature Screw		26460	26462	Hand Lantern-4F	5.1	1.07
503	G-4 1/2	Miniature Bayonet		26469		Hand Lantern-4F	5.1	1.07
509K	G-6	Candelabra Screw		26485		Indicator	24.0	1.47
555	T-3/4	Wedge		44773	44774	Pinball	6.3	1.06
558	TL-3 1/4	Wedge		38269	38270	Auto-Lens End	13.0	1.06
561	T-3	Rigid Loop	12358	39746	40023	Auto	12.8	1.72
562	T-3	Rigid Loop	23019		40024	Auto	13.5	1.72
563	T-3	Rigid Loop	26205		40025	Auto	13.5	1.72
570	T-4 3/4	Rigid Loop	12672			Auto	12.8	1.72
577	T-4 3/4	Double End Cap	23020			Auto	12.8	1.72
585	T-3/4	Wedge		49936		Indicator	28.0	1.06
590	T-3/4	Wedge		18442	18439	Strip Lighting-Xenon	13.5	1.06
591	T-3/4	Wedge		25199	25200	Strip Lighting-Xenon	14.0	1.06
605	G-4 1/2	Miniature Screw		26549		Flashlight-5D	6.15	1.07
612	G-3 1/2	Miniature Two Pin		36935		Indicator	6.3	0.94
623	G-6	S.C. Bayonet		26561	26563	Instrument-2 Series Filaments	28.0	1.44
624	G-6	D.C. Bayonet		26567	26568	Marine-2 Series Filaments	28.0	1.44
631	G-6	S.C. Bayonet	23023	26570		Auto-2 Series Filaments	14.0	1.44
656	T-3/4	Wedge		38866		Indicator	28.0	1.06
657	T-3/4	Wedge		38196		Indicator	28.0	1.06
658	T-3/4	Wedge		39999	40000	Indicator	14.0	1.06
685	T-1	Sub-Midget Flanged			28706	Aircraft	5.0	0.38
705	S-8	S.C. Bayonet		43132		Aircraft	28.0	2.00

Miniature & Sealed Beam Lamps



Lamp Number	Halogen Bulb Size	Lamp Base	Product Code			Primary Application	Design Volts	Maximum Length in.
			Blister Pack	Unit Pack	Bulk Pack			
MINIATURE LAMPS (Continued)								
718AS15	T-1	Sub-Midget Flanged		28727		Aircraft-Selected Candlepower	5.0	0.38
755	T-3/4	Miniature Bayonet		26591	26592	Indicator	6.3	1.19
756	T-3/4	Miniature Bayonet		26593		Indicator	14.0	1.19
757	T-3/4	Miniature Bayonet		26599	26600	Indicator	28.0	1.19
767	Ⓢ T-2 1/4	Miniature Bayonet		11014		Instrument	6.0	1.13
773	Ⓢ T-2 3/4	G-4 Two Pin		11250		Special	12.0	1.05
774	Ⓢ T-2 1/4	G-4 Two Pin		12723	12724	Emergency Lighting	12.0	1.00
777	Ⓢ T-2 1/4	G-4 Two Pin			47618	Flashlight	4.0	1.00
778	Ⓢ T-2 3/4	G-4 Two Pin		49718		Instrument	6.0	1.05
780	Ⓢ T-2 3/4	G-4 Two Pin		18344	18345	Strip Lighting	12.0	1.05
782	Ⓢ T-2 3/4	G-4 Two Pin		44840	44841	Special	12.0	1.05
783	Ⓢ T-2 1/4	G-4 Two Pin		44500	44501	Emergency Lighting	12.0	1.00
784	Ⓢ T-2 1/4	G-4 Two Pin		43760	43761	Emergency Lighting	6.0	1.00
785	Ⓢ T-2 1/4	G-4 Two Pin		43762	43763	Emergency Lighting	6.0	1.00
786	Ⓢ T-2 1/4	G-4 Two Pin		43764	43765	Emergency Lighting	6.0	1.00
787	Ⓢ T-2 1/4	G-4 Two Pin		43115	43116	Instrument	6.0	1.00
788	Ⓢ T-2 1/4	G-4 Two Pin		43117	43118	Instrument	6.0	1.00
789	Ⓢ T-2 3/4	G-4 Two Pin		43119		Instrument	12.0	1.05
790	Ⓢ T-2 3/4	G-4 Two Pin		43121	43122	Instrument	14.0	1.05
791	Ⓢ T-2 3/4	G-4 Two Pin		43123	43124	Instrument	14.0	1.05
795	Ⓢ T-4	S.C. Bayonet		20469		Auto-Signaling	12.8	2.50
862	Ⓢ T-3 1/4	Right Angle Prefocus			14132	Tractor	12.8	2.68
880	Ⓢ T-3 1/4	Axial Plastic, Prefocus	12320		20904	Auto-Foglamp	12.8	2.68
880X	Ⓢ T-3 1/4	Axial Plastic, Prefocus			14694	Auto-Foglamp	12.8	2.68
881	Ⓢ T-3 1/4	Right Angle Prefocus	12334		20905	Auto-Foglamp	12.8	2.68
881X	Ⓢ T-3 1/4	Right Angle Prefocus			11646	Auto-Foglamp	12.8	2.68
882	Ⓢ T-2 1/4	Printed Circuit Socket	26376	13158	13161	Auto-Instrument	12.8	1.18
882X	Ⓢ T-2 1/4	G-4 Two Pin		18167	16772	Instrument	12.8	1.00
884	Ⓢ T-3 1/4	Axial Plastic		14072	14071	Special	12.8	2.68
885	Ⓢ T-3 1/4	Axial Plastic, Prefocus	12335		20907	Auto-Foglamp	12.8	2.68
886	Ⓢ T-3 1/4	Right Angle Prefocus	14689		20909	Auto-Foglamp	12.8	2.68
887	Ⓢ T-3 1/4	Axial Plastic, Prefocus			25639	Tractor	12.8	2.68
888	Ⓢ T-3 1/4	Right Angle Prefocus			25703	Tractor	12.8	2.68
889	Ⓢ T-3 1/4	Right Angle Prefocus	12336		20910	Auto-Signal	12.8	2.68
890	Ⓢ T-3 1/4	Axial Plastic	12337		20911	Auto-Signal	12.8	2.68
891	Ⓢ T-2 1/4	G-4 Two Pin	12308	15246	15248	Auto-Stop	12.8	2.68
892	Ⓢ T-3 1/4	Axial Plastic		16481	20912	Auto	12.8	2.68
893	Ⓢ T-3 1/4	Axial Plastic, Prefocus	12338		20913	Auto-Foglamp	12.8	2.68
893X	Ⓢ T-3 1/4	Axial Plastic, Prefocus			12727	Auto-Foglamp	12.8	2.68
894	Ⓢ T-3 1/4	Right Angle Prefocus	22112	20238	18455	Auto/Tractor	12.8	2.68
896	Ⓢ T-3 1/4	Right Angle Prefocus	22113		20914	Auto-Foglamp	12.8	2.68
898	Ⓢ T-3 1/4	Right Angle Prefocus			12271	Auto-Foglamp	12.8	2.68
899	Ⓢ T-3 1/4	Axial Plastic, Prefocus	22111		12272	Auto-Foglamp	12.8	2.68
901	T-5	Wedge	14273		14007	Garden	12.8	1.49
904	T-5	Wedge	23024	40462	40463	Auto	13.5	1.49
906	T-5	Wedge	12366	40289	40290	Auto	13.0	1.49
908	T-5	Wedge		44754	44755	Emergency Lighting	6.0	1.49
909	T-5	Wedge		44756	44757	Emergency Lighting	6.0	1.49
912	T-5	Wedge	12365	40504	40505	Auto	12.8	1.49
914	T-5	Wedge		44769	44770	Emergency Lighting	4.0	1.49



Lamp Number	Halogen (+)	Bulb Size	Lamp Base	Product Code			Primary Application	Maximum	
				Blister Pack	Unit Pack	Bulk Pack		Design Volts	Length in.
MINIATURE LAMPS (Continued)									
915		T-5	Wedge		44771	44772	Emergency Lighting	12.0	1.49
916		T-5	Wedge	23025	16289	16288	Auto	13.5	1.49
916NA		T-5	Wedge	23026	21860		Auto-Natural Amber Bulb	13.0	1.49
917		T-5	Wedge		44800	44801	Home Appliance	12.0	1.49
918		T-5	Wedge	40179	17837	14008	Garden	12.8	1.49
920		T-5	Wedge	26199			Auto	12.8	1.49
921		T-5	Wedge	12307	43374	43375	Auto	12.8	1.49
922		T-5	Wedge	23027	13274	13275	Auto	12.8	1.49
923		T-5	Wedge	40180	16955	14009	Garden	12.8	1.49
926		T-5	Wedge		13483	13484	Emergency Lighting	4.0	1.49
927		T-5	Wedge		13485	13486	Emergency Lighting	6.0	1.49
939		T-5	Wedge		16975	15285	Emergency Lighting	6.0	1.49
957		T-4 ¹ / ₂	Miniature Bayonet			26671	Signal	9.84	1.38
1003		B-6	S.C. Bayonet	12367	26709	26711	Auto	12.8	1.75
1004		B-6	D.C. Bayonet	12373	26726	26728	Marine	12.8	1.75
1034		S-8	D.C. Index		26775		Auto-Stop/Tail	12.8/14.0	2.00
1047		RP-11	S.C. Bayonet		26815		Aircraft	26.0	2.25
1062		RP-11	D.C. Bayonet		32147		Special	40.0	2.25
1073		S-8	S.C. Bayonet	40134	26838		Auto	12.8	2.00
1076		S-8	D.C. Bayonet		26854	26856	Auto	12.8	2.00
1096		S-8	D.C. Pf. (S)		37169		Instrument	6.0	2.00
1129		S-8	S.C. Bayonet		26872		Special	6.4	2.00
1133		RP-11	S.C. Bayonet		26885		Instrument	6.2	2.25
1141		S-8	S.C. Bayonet	12346	26903	26905	Auto	12.8	2.00
1142		S-8	D.C. Bayonet		26917	26919	Auto	12.8	2.00
1152		S-8	D.C. Bayonet		26945	26946	Special	12.8	2.00
1154		S-8	D.C. Index	12297			Auto-Stop/Tail	6.4/7.0	2.00
1155		G-6	S.C. Bayonet		26955		Auto-2 Series Filaments	13.5	1.44
1156		S-8	S.C. Bayonet	12344	26960	26963	Auto-Stop	12.8	2.00
1156KR		S-8	S.C. Bayonet	23334			Auto-Stop-Long Life	12.8	2.00
1156NA		S-8	S.C. Bayonet	21028	20248		Auto-Natural Amber Bulb	12.8	2.00
1157		S-8	D.C. Index	12294	26969	18619	Auto-Stop/Tail	12.8/14.0	2.00
1157KR		S-8	D.C. Index	23337			Auto-Stop/Tail-Long Life	12.8/14.0	2.00
1157NA		S-8	D.C. Index	12310	26975	26976	Auto-Natural Amber Bulb	12.8/14.0	2.00
1176		S-8	D.C. Bayonet		27004		Auto-Stop/Tail	12.8/14.0	2.00
1195		RP-11	S.C. Bayonet		27021	27023	Auto	12.5	2.25
1196		RP-11	D.C. Bayonet		27026		Auto	12.5	2.25
1203		S-8	S.C. Bayonet		27032	27033	Special	28.0	2.00
1209		RP-11	S.C. Pf. (B)		27040		Instrument	6.1	2.25
1224		G-6	D.C. Bayonet		27044		Marine	34.0	1.44
1229		S-8	D.C. Bayonet		39904		Special	40.0	2.00
1240		G-16 ¹ / ₂	D.C. Pf. (A)		27081		Special	32.0	3.00
1251		G-6	S.C. Bayonet		27092	27093	Instrument-2 Series Filaments	28.0	1.44
1252		G-6	D.C. Bayonet		27097		Instrument-2 Series Filaments	28.0	1.44
1295NA		S-8	S.C. Bayonet		22523		Auto-Special-Natural Amber Bulb	12.5	2.00
1308		B-6	S.C. Bayonet		12824		Aircraft	28.0	1.75
1309		B-6	S.C. Bayonet		27118		Aircraft	28.0	1.75
1315		G-5	S.C. Bayonet		32098		Aircraft	2.5	1.25
1317		B-6	S.C. Bayonet		34265		Aircraft	6.0	1.75
1383		R-12	S.C. Bayonet		27150		Auto-Reflectorized	13.0	2.63

Miniature & Sealed Beam Lamps



Lamp Number	Halogen Bulb Size (in.)	Lamp Base	Product Code			Primary Application	Design Volts	Maximum Length in.
			Blister Pack	Unit Pack	Bulk Pack			
MINIATURE LAMPS (Continued)								
1385	R-12	S.C. Bayonet		27154		Special-Reflectorized	28.0	2.63
1388	R-12	D.C. Bayonet		27159		Special-Reflectorized	24.0	2.63
1408	T-3 ¹ / ₄	Miniature Bayonet		27179		Signal	10.0	1.19
1414	T-4 ¹ / ₂	Miniature Bayonet		27181		Aircraft	14.0	1.38
1434	T-5	S.C. Bayonet		27193		Instrument-Silver Contacts	3.7	1.75
1445	G-3 ¹ / ₂	Miniature Bayonet	12329	27207	27209	Auto/Toy Train	14.4	0.94
1449	G-3 ¹ / ₂	Miniature Screw		27252		Toy Train	14.0	0.94
1450	G-3 ¹ / ₂	Miniature Bayonet		27263		Indicator	24.0	0.94
1460	S-8	D.C. Pf. (A)		28310		Medical	6.5	2.00
1460X	S-8	D.C. Pf. (A)		37342	37343	Microscope-Silver Contacts	6.5	2.00
1468	S-8	D.C. Pf. (S)		27305		Medical-Selected Bulb	6.0	2.00
1468X	S-8	D.C. Pf. (S)		42677		Medical	6.0	2.00
1487	T-3 ¹ / ₄	Miniature Screw		27356		Indicator	14.0	1.19
1489	T-5	S.C. Bayonet		27369		Instrument	6.5	1.75
1493	S-8	D.C. Bayonet		27382		Instrument	6.5	2.00
1495	T-4 ¹ / ₂	Miniature Bayonet		27392		Aircraft	28.0	1.38
1495X	T-4 ¹ / ₂	Miniature Bayonet		44842		Aircraft-Gas Filled	28.0	1.38
1534	S-6	D.C. Index		47773		Aircraft	5.0/28.0	1.82
1561	S-11	S.C. Pf. (B)		27431		Instrument-Selected Bulb	6.3	2.00
1563	S-8	S.C. Bayonet			38249	Military-Blackout Lamp	28.0	2.00
1565	S-8	S.C. Pf. (S)		27434		Instrument-Selected Bulb	5.1	2.00
1591	S-8	S.C. Bayonet		40943		Aircraft	28.0	2.00
1591AF	S-8	S.C. Bayonet		40945		Aircraft-Frosted Bulb	28.0	2.00
1594	S-8	D.C. Bayonet		27439		Instrument-Selected Bulb	6.0	2.00
1612	S-8	D.C. Bayonet		27461		Instrument-Selected Bulb	5.4	2.00
1619	S-8	S.C. Bayonet		27472		Instrument-Selected Bulb	6.7	2.00
1630	S-8	D.C. Pf. (A)		27488	27489	Instrument	6.5	2.00
1631X	S-8	D.C. Pf. (A)		27491		Instrument-Silver Contacts	6.5	2.00
1634	S-8	D.C. Pf. (A)		27496		Instrument	20.0	2.00
1638	S-8	D.C. Bayonet		27504		Marine-2 Series Filaments	28.0	2.00
1649	S-8	D.C. Pf. (A)		27513		Instrument	6.5	2.00
1651	S-8	S.C. Bayonet		27515		Hand Lantern-4F	5.0	2.00
1662	S-8	D.C. Index		27529	27530	Aircraft-Inverted Wiring vs 1157	28.0/28.0	2.00
1665	S-8	S.C. Bayonet		27532		Aircraft	28.0	2.00
1665AF	S-8	S.C. Bayonet		27533		Aircraft-Frosted Bulb	28.0	2.00
1680	S-8	S.C. Bayonet		27548		Aircraft	6.0	2.00
1680X	S-8	S.C. Bayonet		33995		Aircraft-Silver Contact	6.0	2.00
1683	S-8	S.C. Bayonet		27557	27559	Aircraft-2 Series Filaments	28.0	2.00
1691	S-8	S.C. Bayonet		27566		Aircraft-2 Series Filaments	28.0	2.00
1691AF	S-8	S.C. Bayonet		27568		Aircraft-2 Series Filaments-Frosted Bulb	28.0	2.00
1692	S-8	D.C. Bayonet		27571		Marine-2 Series Filaments	28.0	2.00
1723	S-11	S.C. Bayonet		27596		Aircraft	6.2	2.38
1731	S-11	S.C. Pf. (B)		27608		Instrument-Silver Contacts	6.3	2.38
1763	S-11	S.C. Pf. (B)		27627		Instrument-Selected Bulb	6.1	2.38
1777	S-8	S.C. Bayonet		27630		Aircraft	12.8	2.00
1810	T-3 ¹ / ₄	Miniature Bayonet		27659		Special	6.3	1.19
1813	T-3 ¹ / ₄	Miniature Bayonet		27667		Radio	14.4	1.19
1815	T-3 ¹ / ₄	Miniature Bayonet		27677	27679	Indicator	14.0	1.19
1816	T-3 ¹ / ₄	Miniature Bayonet	12359	27688	27690	Auto	13.0	1.19
1818	T-3 ¹ / ₄	Miniature Bayonet		27707		Aircraft	24.0	1.19



Lamp Number	Halogen Bulb Size	Lamp Base	Product Code			Primary Application	Design Volts	Maximum Length in.
			Blister Pack	Unit Pack	Bulk Pack			
MINIATURE LAMPS (Continued)								
1819	T-3/4	Miniature Bayonet		27711	27712	Indicator	28.0	1.19
1820	T-3/4	Miniature Bayonet		27727		Indicator	28.0	1.19
1822	T-3/4	Miniature Bayonet		27749		Aircraft	36.0	1.19
1828	T-3/4	Miniature Bayonet		27772		Aircraft	37.5	1.19
1829	T-3/4	Miniature Bayonet		27776		Indicator	28.0	1.19
1835	T-3/4	Miniature Bayonet		27804	27805	Indicator	55.0	1.19
1843	T-3/4	Miniature Bayonet		27816		Indicator	28.0	1.19
1847	T-3/4	Miniature Bayonet		27819		Radio	6.3	1.19
1850	T-3/4	Miniature Bayonet		27833		Signal-Filament Oriented	5.0	1.19
1850W	T-3/4	Miniature Bayonet			38689	Signal	5.0	1.19
1864	T-3/4	Miniature Bayonet		27862	27863	Aircraft	28.0	1.19
1866	T-3/4	Miniature Bayonet		27868		Radio	6.3	1.19
1873	T-3/4	Miniature Bayonet		40383	40384	Aircraft	28.0	1.19
1874	T-5	S.C. Bayonet		27882		Instrument-Selected Bulb	3.7	1.75
1876	T-5	S.C. Bayonet		27889	27890	Photo Scanner-Silver Contacts	3.5	1.75
1889	T-3/4	Miniature Bayonet		27907		Auto	14.0	1.19
1891	T-3/4	Miniature Bayonet	12331	27917	27919	Auto	14.0	1.19
1892	T-3/4	Miniature Bayonet		27927		Auto	14.4	1.19
1893	T-3/4	Miniature Bayonet	12332	27935	27937	Auto	14.0	1.19
1895	G-4/2	Miniature Bayonet	12330	27945	27948	Auto	14.0	1.07
1895R	G-4/2	Miniature Bayonet			34508	Auto-Red Coated	14.0	1.07
1939X	T-7	S.C. Bayonet		34021		Aircraft	28.0	2.16
1940	T-7	S.C. Bayonet		28008		Aircraft	14.0	2.16
1944	T-7	S.C. Bayonet		37034		Special-Silver Contacts	14.0	2.25
1944X	T-7	S.C. Bayonet		45087		Special-Silver Contacts-Oriented	14.0	2.25
1946	T-3	Wire Terminals		18617		Aircraft	28.0	1.46
1958	⊕ T-4	Tab		28011		Aircraft-Quartz	28.0	2.25
1962B	⊕ T-3	Wire Terminals		39641		Special-Quartz-Horizontal Leads	8.5	1.14
1962BG	⊕ T-3	Wire Terminals			12859	Aircraft-Quartz-Leads Down	8.5	1.14
1962DX	⊕ T-3	Wire Terminals			37947	Special-Quartz-Bare Leads Down	8.5	1.14
1962DZ	⊕ T-3	Wire Terminals		44152		Special-Quartz-Insulated Leads Down	8.5	1.20
1962TY	⊕ T-3	Wire Terminals		13667		Medical-Quartz-Long Leads Horizontal	8.5	1.20
1967	⊕ T-3	Special Sleeve		28019		Aircraft-Quartz	28.0	2.25
1968	⊕ T-3	Double Slide		28034		Aircraft-Quartz	28.0	1.68
1970	⊕ T-3	Special Sleeve		28036		Aircraft-Quartz	28.0	2.25
1970X	⊕ T-3	Special Sleeve		41938		Aircraft-Quartz-Supported Filament	28.0	2.25
1974	⊕ T-3	Wire Terminals		32780		Instrument	6.0	1.14
1978X	⊕ T-3	Special		38545		Aircraft-Quartz	10.0	2.15
1982	⊕ T-3	S.C. Bayonet		38627		Aircraft-Quartz	28.0	1.88
1982SP	⊕ T-3	S.C. Bayonet		21061		Aircraft-Quartz	28.0	1.97
1983	⊕ T-4	Two Pin		39718		Aircraft-Quartz	10.0	1.80
1986	⊕ T-4	Prefocus Collar, Leads		44717		Aircraft-Quartz	28.0	2.00
1987	⊕ T-4	D.C. Bayonet		47695		Aircraft-Quartz	28.0	2.44
1988	⊕ T-3	Special Wire Leads		38535		Military-Aircraft	10.0	2.15
2031	S-8	Wire Terminals			13600	Truck	12.8	1.75
2040	⊕ T-2 1/4	Wedge	12326	19280		Auto-Light Bar	12.8	1.25
2057	S-8	D.C. Index	12296	44760	18620	Auto-Stop/Tail	12.8/14.0	2.00
2057KR	S-8	D.C. Index	23339			Auto-Stop/Tail-Long Life	12.8/14.0	2.00
2057NA	S-8	D.C. Index	12312	44763	44764	Auto-Natural Amber Bulb	12.8/14.0	2.00
2058U	S-8	Wire Terminals			12899	Truck	12.8/14.0	1.81



Lamp Number	Halogen (H)	Bulb Size	Lamp Base	Product Code			Primary Application	Design Volts	Maximum Length in.
				Blister Pack	Unit Pack	Bulk Pack			
MINIATURE LAMPS (Continued)									
2059		T-2 $\frac{1}{2}$	Miniature Bayonet		26697		Aircraft-Reading	12.0	1.30
2059X		T-2 $\frac{1}{2}$	Miniature Bayonet		26698		Aircraft-Reading-Blacktopped	12.0	1.30
2074	H	T-3	Wire Terminals			21494	Instrument-Quartz	7.0	1.14
2121D		TL-3	Wire Terminals			35625	Flashlight-Leads Down	2.25	0.82
2144		S-8	Wire Terminals			28085	Truck	12.8	1.75
2155		S-8	Wire Terminals			32701	Truck	28.0/28.0	1.75
2232		S-8	S.C. Bayonet		34763		Aircraft-Spiral Lead	28.0	2.00
2232LL		S-8	S.C. Bayonet		26702		Aircraft-Long Life	28.0	2.00
2232SB		S-8	S.C. Bayonet		43134		Aircraft-Silver Bowl	28.0	2.00
2233		S-8	S.C. Bayonet		36906		Aircraft-Spiral Lead	28.0	2.00
2286D		T-3 $\frac{1}{4}$	Wire Term Down			44964	Truck-Leads Down	14.0	1.05
2331		RP-11	D.C. Pf. (S)		28100		Instrument	5.9/6.2	2.25
2357		S-8	D.C. Index	12298	16291	16290	Auto-Stop/Tail	12.8/14.0	2.00
2357NA		S-8	D.C. Index	12299	15698	15699	Auto-Natural Amber Bulb	12.8/14.0	2.00
2396		S-8	S.C. Bayonet	26479	18047		Auto	12.8	2.00
2397		S-8	D.C. Index	27560			Auto-Stop/Tail	12.8/14.0	2.00
2556	H	T-3	Two Pin			19792	Aircraft-Quartz	28.0	1.46
2577		S-6	S.C. Bayonet		20246		Bowling Pin Spotter	3.5	1.75
2586	H	T-4	Wire Terminal			19566	Aircraft-Quartz	28.0	1.90
2604X	H	TL-2 $\frac{3}{4}$	G-4 Two Pin		43805		Instrument-Lens End	5.0	1.18
3011		S-11	S.C. Bayonet		36508		Aircraft	28.0	2.38
3057		S-8	Plastic Wedge	12305	18389		Auto-Stop/Tail	12.8/14.0	2.09
3057KR		S-8	Plastic Wedge	26378			Auto-Stop/Tail-Long Life	12.8/14.0	2.09
3057NA		S-8	Plastic Wedge	12313	18391		Auto-Natural Amber Bulb	12.8/14.0	2.09
3078		T-3	Special		14689		Aircraft-Long Life 1978X	10.0	2.15
3155		S-8	Plastic Wedge	23028			Auto	12.8	2.09
3156		S-8	Plastic Wedge	12351	21863		Auto-Stop	12.8	2.09
3156KR		S-8	Plastic Wedge	27565			Auto-Long Life	12.8	2.09
3157		S-8	Plastic Wedge	12306	17172		Auto-Stop/Tail	12.8/14.0	2.09
3157KR		S-8	Plastic Wedge	26377			Auto-Long Life	12.8/14.0	2.09
3157NA		S-8	Plastic Wedge	12314	17173		Auto-Natural Amber Bulb	12.8/14.0	2.09
3157NAKR		S-8	Plastic Wedge	26380			Auto-Natural Amber Bulb-Long Life	12.8/14.0	2.09
3357/3457		S-8	Plastic Wedge	14387	22525		Auto-Stop/Tail	12.8/14.0	2.09
3357KR/3457KR		S-8	Plastic Wedge	26379			Auto-Long Life	12.8/14.0	2.09
3357NA/3457NA		S-8	Plastic Wedge	14388	22526		Auto-Natural Amber Bulb	12.8/14.0	2.09
3496		T-7	D.C. Index	25834			Auto-Japanese Stop/Tail	12.8/14.0	2.00
3497		T-7	S.C. Bayonet	25835			Auto-Japanese Stop	12.8	2.00
3652		T-3 $\frac{1}{4}$	Wedge	25837			Auto-Japanese	13.5	1.06
5004CW		T-5	Miniature Pinless		28154		Aircraft-Fluorescent	A.C.	6.00
5004WW		T-5	Miniature Pinless		28155		Aircraft-Fluorescent	A.C.	6.00
5008CW		T-5	Miniature Pinless		28160		Aircraft-Fluorescent	A.C.	12.00
5008WW		T-5	Miniature Pinless		28163		Aircraft-Fluorescent	A.C.	12.00
5013CW		T-5	Miniature Pinless		28168		Aircraft-Fluorescent	A.C.	21.00
5013WW		T-5	Miniature Pinless		28169		Aircraft-Fluorescent	A.C.	21.00
5104WW		T-5	Miniature Bi-Pin		28173		Aircraft-Fluorescent	A.C.	6.00
5104CW		T-5	Miniature Bi-Pin		27367		Aircraft-Fluorescent	A.C.	6.00
5106CW		T-5	Miniature Bi-Pin		12774		Aircraft-Fluorescent	A.C.	9.00
5106WW		T-5	Miniature Bi-Pin		33612		Aircraft-Fluorescent	A.C.	9.00
5108WW		T-5	Miniature Bi-Pin		28175		Aircraft-Fluorescent	A.C.	12.00
5108CW		T-5	Miniature Bi-Pin		27466		Aircraft-Fluorescent	A.C.	12.00



Lamp Number	Halogen Bulb Size (1)	Lamp Base	Product Code			Primary Application	Design Volts	Maximum Length in.
			Blister Pack	Unit Pack	Bulk Pack			
MINIATURE LAMPS (Continued)								
5113CW	T-5	Miniature Bi-Pin		12775		Aircraft-Fluorescent	A.C.	21.00
5113WW	T-5	Miniature Bi-Pin		28178		Aircraft-Fluorescent	A.C.	21.00
7387	T-1 ³ / ₄	Bi-Pin M-23		28926		Indicator	28.0	0.61
7440	T-7	Wedge	26200			Auto-Japanese Import-Stop	13.5	1.75
7443	T-7	Wedge		26201		Auto-Japanese Import-Stop/Tail	13.5/13.5	1.75
9003/HB2	⊕ T-5	P43T-38	22432	22389	21611	Auto-Headlamp	12.8/12.8	3.62
9004/HB1	⊕ T-4 ³ / ₄	Axial Plastic	18508	13382	18699	Auto-Headlamp	12.8/12.8	4.17
9004HO	⊕ T-4 ³ / ₄	Axial Plastic	27561	27693		Auto-Headlamp-High Output	12.8/12.8	4.17
9004XL	⊕ T-4 ³ / ₄	Axial Plastic	13993	11249	20559	Auto-Headlamp-Long Life	12.8/12.8	4.17
9005/HB3	⊕ T-3 ¹ / ₄	Right Angle, Plastic	18509	13384	36431	Auto-Headlamp	12.8	3.13
9006/HB4	⊕ T-3 ¹ / ₄	Right Angle, Plastic	18510	13397	36432	Auto-Headlamp	12.8	3.13
9007/HB5	⊕ T-4 ³ / ₄	Axial Plastic	22388	20551		Auto-Headlamp	12.8/12.8	4.17
9007LL	⊕ T-4 ¹ / ₂	Axial Plastic			26022	Auto-Headlamp-Long Life	12.8/12.8	4.17
9011	⊕ T-3 ¹ / ₄	PX20D			14776	Auto-Headlamp-HIR	12.8	3.50
50310/1 (H1-55)	⊕ T-3 ¹ / ₂	P14.5S		27328	32376	Auto-Headlamp-Import	13.2	2.66
50320/1	⊕ T-3 ¹ / ₂	P14.5S		27569		Bus-Headlamp-Import	28.0	2.46
50340 (H3-55)	⊕ T-3 ¹ / ₂	PK22S	12339	27331	22132	Auto-Foglamp	13.2	1.65
50340HD (H3-55)	⊕ T-3 ¹ / ₂	PK22S			23445	CIM	13.2	1.65
50340LL (H3-55)	⊕ T-3 ¹ / ₂	PK22S			35044	Auto-Foglamp-Long Life	13.2	1.65
50350 (H3-70)	⊕ T-3 ¹ / ₂	PK22S		27332	23438	CIM	28.0	1.65
50390 (H3-35)	⊕ T-3 ¹ / ₂	PK22S			23442	CIM	13.2	1.65
50410 (H2-55)	⊕ T-3 ¹ / ₂	X511		27330	22130	Auto-Headlamp-Import	13.2	1.65
50440 (H4-60/55)	⊕ T-5	P43T-38	18132	27334	22133	Auto/Motorcycle-Headlamp-Import	13.2/13.2	3.62
50450 (H4-75/70)	⊕ T-5	P43T-38		27342	30833	Bus-Headlamp-Import	28.0/28.0	3.62
52130 (H3-100)	⊕ T-3 ¹ / ₂	PK22S	12341	27343		Off Road-Auxiliary	13.2	1.65
52140 (H1-100)	⊕ T-3 ¹ / ₄	P14.5S		27329		Off Road-Auxiliary	13.2	2.66
52590HD (H3-65)	⊕ T-3 ¹ / ₂	PK22S			23428	CIM	28.0	1.65
58520 (H7-55)	⊕ T-3 ¹ / ₄	PX26D	26374			Auto-Headlamp-Import	13.2	2.36
58710	⊕ T-2 ³ / ₄	S.C. Miniature Flanged		64371		Flashlight	7.2	1.25
58720	⊕ T-2 ³ / ₄	S.C. Miniature Flanged			64363	Flashlight	3.8	1.25
58760	⊕ T-2 ³ / ₄	S.C. Miniature Flanged			64364	Flashlight	6.2	1.25
A-103	⊕ T-3	Special		26696		Aircraft	28.0	2.15
B1A	T-3 ¹ / ₄	Miniature Bayonet		12064		Neon Glow Lamp (NE-51)	120.0	1.19
B2A	T-3 ¹ / ₄	Miniature Bayonet		12065		Neon Glow Lamp (NE-51H)	120.0	1.19
B7A	T-4 ¹ / ₂	Candelabra Screw		31675		Neon Glow Lamp (NE-45)	120.0	1.54
C5W	T-3 ¹ / ₂	SV8.5/8	23312		30872	Auto-Import-Festoon	13.5	1.45
DE3021	T-2 ¹ / ₄	SV7MM	25323	12086		Auto-Import-Festoon	14.0	1.15
DE3022	T-2 ¹ / ₄	SV7MM	12353			Auto-Import-Festoon	13.0	1.18
DE3175	T-3 ¹ / ₄	SV8.5MM	12354	12084		Auto-Import-Festoon	13.0	1.25
DE3425	T-4	SV8.5MM		12085		Auto-Import-Festoon	13.0	1.50
GE7575	T-3 ¹ / ₂	SV8.5/8			34450	Strip Lighting/Auto-Festoon	13.5	1.65
GE7576	T-3 ¹ / ₂	SV8.5/8	23324		25641	Strip Lighting/Auto-Festoon	13.5	1.65
GE7579	T-3 ¹ / ₂	SV8.5/8			25642	Strip Lighting-Festoon	28.0	1.65
GE7580	T-3 ¹ / ₂	SV8.5/8			25644	Strip Lighting-Festoon	28.0	1.65
H27W/1	⊕ T-3 ¹ / ₄	PG13	12320		20904	Import-Foglamp-See 880	13.5	2.68
H27W/2	⊕ T-3 ¹ / ₄	PGJ13	12334		20905	Import-Foglamp-See 881	13.5	2.68
KPR102	B-3 ¹ / ₂	S.C. Miniature Flanged		22961		Flashlight-Krypton-2D	2.4	1.25
KPR103	B-3 ¹ / ₂	S.C. Miniature Flanged		23150		Flashlight-Krypton-3D	3.6	1.25
KPR104	B-3 ¹ / ₂	S.C. Miniature Flanged		23151		Flashlight-Krypton-2D	2.2	1.25
KPR113	B-3 ¹ / ₂	S.C. Miniature Flanged		23153		Flashlight-Krypton-4D	4.8	1.25



Lamp Number	Halogen (W)	Bulb Size	Lamp Base	Product Code			Primary Application	Design Volts	Maximum Length in.
				Blister Pack	Unit Pack	Bulk Pack			
MINIATURE LAMPS (Continued)									
KPR118		B-3 1/2	S.C. Miniature Flanged	23154			Flashlight-Krypton-6D	7.2	1.25
ML20/OF-28		T-8	Disk		12571		Aircraft	28.0	5.75
ML20/R-28		T-8	Disk		28433		Aircraft-Red Coated	28.0	5.75
P25-1/P21W		S-8	S.C. Bayonet	23306		11601	Auto-Import-Stop	13.5	2.00
P25-2/P21/5W		S-8	D.C. Index	23303		11604	Auto-Import-Stop/Tail	13.5/13.5	2.00
P21WLL		S-8	S.C. Bayonet			30852	Auto-Import-Stop-Long Life	13.5	2.00
P21/5W LL		S-8	D.C. Index			30855	Auto-Import-Stop/Tail-Long Life	13.5/13.5	2.00
P21/5W		S-8	D.C. Index			30856	Bus-Import-Stop/Tail	28.0/28.0	2.00
P21/4W		S-8	D.C. Index	27561		30857	Auto-Import-Stop/Tail	13.5/13.5	2.00
PC161		T-3 1/4	Printed Circuit Socket			23036	Auto-Instrument Panel	14.0	1.11
PC168		T-3 1/4	Printed Circuit Socket		27222	23037	Auto-Instrument Panel	14.0	1.11
PC194		T-3 1/4	Printed Circuit Socket		72221	23021	Auto-Instrument Panel	14.0	1.11
PC194R		T-3 1/4	Printed Circuit Socket			20270	Auto-Instrument Panel-Red Coated	14.0	1.11
PR2		B-3 1/2	S.C. Miniature Flanged	12675	25181		Flashlight-2D	2.38	1.25
PR3		B-3 1/2	S.C. Miniature Flanged	12676	25193		Flashlight-3D	3.57	1.25
PR4		B-3 1/2	S.C. Miniature Flanged	12677	25207		Flashlight-2C	2.33	1.25
PR6		B-3 1/2	S.C. Miniature Flanged		25222		Flashlight-2D HD	2.47	1.25
PR7		B-3 1/2	S.C. Miniature Flanged		25235		Flashlight-3D HD	3.7	1.25
PR12		B-3 1/2	S.C. Miniature Flanged	12680	25252		Flashlight-5D	5.95	1.25
PR13		B-3 1/2	S.C. Miniature Flanged	12681	25262		Hand Lantern-4F	4.75	1.25
PR18		B-3 1/2	S.C. Miniature Flanged		25289		Flashlight-6D	7.2	1.25
PY21W		S-8	BAU 15s			32648	Auto-Import-Amber-Stop	13.5	2.00
R5W LL		G-6	S.C. Bayonet	23314		30859	Auto-Import-Long Life	13.5	1.47
R10W LL		G-6	S.C. Bayonet	23322		35417	Auto-Import-Long Life	13.5	1.47
SE1274		T-1 3/4	BA75MM		12088		Auto-Import	14.4	0.75
T4W		T-2 3/4	Miniature Bayonet	23318			Auto-Import	13.5	1.08
W3W		T-3 1/4	Wedge	27562		22134	Auto-Import	13.5	1.06
W5W		T-3 1/4	Wedge	27563		31965	Auto-Import	13.5	1.06
W16W		T-5	Wedge			26353	Auto-Import	13.5	1.49
SEALED BEAM LAMPS									
4000		PAR46	3 Contact Lugs		18511		Auto-Headlamp-Low Beam	12.8/12.8	4.00
4001		PAR46	2 Contact Lugs		18516		Auto-Headlamp-High Beam	12.8	4.00
4013		PAR46	Screw Terminals		24327	24325	Tractor-Flood	6.4	3.75
4014		PAR36	Screw Terminals		24339	24338	Emergency Building Lighting	6.4	2.75
4019		PAR46	Screw Terminals		24369		Tractor	6.2	3.75
4040		PAR46	3 Contact Lugs		38418		Truck-Headlamp-Long Life	12.8/12.8	4.00
4042		PAR36	Screw Terminals		39585	39586	Emergency Building Lighting	6.4	2.75
4044		PAR36	Screw Terminals		40588	40589	Emergency Building Lighting	12.0	2.75
4044-1		PAR36	Slip-on Terminals		10540	10541	Emergency Building Lighting	12.0	2.75
4313		PAR36	Screw Terminals		25051		Aircraft-Landing	13.0	2.75
4340		PAR36	Slip-on Terminals		39366	39367	Electric Truck Worklight	48.0	2.75
4350		PAR36	Slip-on Terminals		39362	39363	Electric Truck Worklight	36.0	2.75
4402A		PAR36	Screw Terminals		12961		Amber Lens-CIM Signal	28.0	2.75
4405		PAR36	Screw Terminals		24425	24423	Spotlamp	12.8	2.75
4406		PAR36	Screw Terminals		24430	24428	Tractor-Flood	12.8	2.75
4406-1		PAR36	Slip-on Terminals			36629	Tractor-Flood	12.8	2.75
4409X		PAR36	Screw Terminals			41240	Tractor	12.8	2.75
4410		PAR36	Screw Terminals		24439		Tractor-Backup-Flood	12.8	2.75
4411		PAR36	Screw Terminals		24448	24443	Tractor	12.8	2.75



Lamp Number	Halogen Bulb Size (in.)	Lamp Base	Product Code			Primary Application	Design Volts	Maximum Length in.
			Blister Pack	Unit Pack	Bulk Pack			
SEALED BEAM LAMPS (Continued)								
4411-1	PAR36	Slip-on Terminals		37889	37890	Tractor	12.8	2.75
4412	PAR46	Screw Terminals		24454	24453	Foglamp	12.8	3.75
4412A	PAR46	Screw Terminals		24460	24459	Yellow-Foglamp	12.8	3.75
4413	PAR46	Screw Terminals		22981	24464	Tractor-Flood	12.8	3.75
4414	PAR36	Screw Terminals		24478	24477	Emergency Building Lighting	12.8	2.75
4414-1	PAR36	Slip-on Terminals			36305	Signal	12.8	2.75
4414A	PAR36	Screw Terminals		24483		Amber Lens-Warning Signal	12.8	2.75
4414R	PAR36	Screw Terminals		24487		Red Lens-Warning Signal	12.8	2.75
4415	PAR36	Screw Terminals		22982	24490	Foglamp	12.8	2.75
4415A	PAR36	Screw Terminals		24499	24497	Amber Lens-Foglamp	12.8	2.75
4416	PAR36	Screw Terminals		22983	24503	Spotlamp	12.8	2.75
4416-1	PAR36	Slip-on Terminals			34901	Spotlamp	12.8	2.75
4416A	PAR36	Screw Terminals		24506		Amber Lens-Signal	12.8	2.75
4416R	PAR36	Screw Terminals		24513		Red Lens-Signal	12.8	2.75
4419	PAR46	Screw Terminals		24531	24525	Tractor	12.8	3.75
4421	PAR46	Slip-on Terminals		24539	24541	Special Service	13.0	3.75
4422	PAR36	Screw Terminals		24542		Tractor	12.8	2.75
4434A	PAR46	Screw Terminals		24572		Amber Lens-School Bus-Signal	12.8	3.75
4435	PAR46	Screw Terminals		24577	24576	Spotlamp	12.8	3.75
4436	PAR46	Screw Terminals		24582		Signal	12.8	3.75
4436-3	PAR46	Combination			16487	Signal	12.8	3.75
4440X	PAR36	3 Contact Lugs		39932	39933	Tractor	12.8/12.8	3.00
4440X-1	PAR36	3 Slip-on Terminals		39748		Tractor	12.8/12.8	2.75
4446	PAR36	Screw Terminals		37046	37047	Emergency Building Lighting	12.8	2.75
4460X	PAR36	3 Screw Terminals		40176		Tractor	12.8/12.8	2.75
4461	PAR36	Screw Terminals		24592		Tractor	12.8	2.75
4466	PAR36	Screw Terminals		24596		Tractor	12.8	2.75
4478	PAR46	2 Contact Lugs		24613		CIM-Flood	13.0	4.00
4502	PAR36	Screw Terminals		24627		Military-Headlamp	28.0	2.75
4505	PAR36	Screw Terminals		24640	24638	Aircraft-Navigation	28.0	2.75
4509	PAR36	Screw Terminals		24650	24649	Aircraft-Landing Spotlamp	13.0	2.75
4509X	PAR36	Screw Terminals		41503		Marine-Spotlamp	13.0	2.75
4509Y	PAR36	Screw Terminals		11524		Special Service	13.0	2.75
4510	PAR36	Screw Terminals		24654	24653	Tractor-Flood/Emergency Building Lighting	6.4	2.75
4511	PAR36	Screw Terminals		24663	24661	Tractor	6.2	2.75
4515	PAR36	Screw Terminals		24673	24671	Spotlamp	6.4	2.75
4516	PAR36	Screw Terminals		24678		Spotlamp	6.2	2.75
4519	PAR36	Screw Terminals		24690	24689	Marine	13.0	2.75
4522	PAR46	Screw Terminals		24700		Tractor	13.0	3.75
4530	PAR46	Screw Terminals		24721		Flashing Signal	26.0	3.75
4531	PAR46	Screw Terminals		24726		Military-Headlamp	12.5	3.75
4532	PAR46	Screw Terminals		19628		Aircraft	28.0/28.0	3.75
4535	PAR46	Screw Terminals		24735	24733	Spotlamp	6.4	3.75
4537	PAR46	Screw Terminals		24742		Aircraft-Landing	13.0	3.75
4537-2	PAR46	Screw Terminals		40822	40823	Spotlamp	13.0	3.75
4537X	PAR46	Screw Terminals		39022	39023	Marine-Spotlamp	13.0	3.75
4537Y-2	PAR46	Slip-on Terminals			21060	Special Service	13.0	3.75
4541	PAR56	Screw Terminals		24756		Aircraft-Landing	28.0	4.50
4543	PAR56	Screw Terminals		24764		Marine-Spotlamp	12.5	4.50



Lamp Number	Halogen Bulb Size (in.)	Lamp Base	Product Code			Primary Application	Maximum Length in.	
			Blister Pack	Unit Pack	Bulk Pack		Design Volts	
SEALED BEAM LAMPS (Continued)								
4545	PAR56	Screw Terminals		24768		Marine-Searchlight	12.0	4.50
4546	PAR36	Screw Terminals		24780	24783	Hand Lantern	4.7	2.75
4546-1	PAR36	Slip-on Terminals		24770	24775	Hand Lantern	4.7	2.75
4547	PAR36	Screw Terminals		24788	24787	Hand Lantern	4.75	2.75
4551	PAR46	Screw Terminals		24795		Aircraft-Taxiing	28.0	3.75
4552	PAR64	Screw Terminals		40576		Aircraft-Landing	28.0	3.75
4553	PAR46	Screw Terminals		24799		Aircraft-Landing	28.0	3.75
4554	PAR46	Screw Terminals		24802		Aircraft-Taxiing	28.0	3.75
4555	PAR64	Screw Terminals		40583		Aircraft-Landing	115.0	3.75
4556	PAR46	Screw Terminals		40580		Aircraft-Landing	28.0	3.75
4557	PAR64	3 Screw Terminals		40581		Aircraft-Landing/Taxi	28.0/28.0	3.75
4559	PAR64	Screw Terminals		40578		Aircraft-Landing	28.0	3.75
4570	PAR46	Screw Terminals		24828		Aircraft-Taxiing	28.0	3.75
4570X	PAR46	Screw Terminals		19502		Tractor	28.0	3.75
4571	PAR46	Screw Terminals		24830		Special Service-Flood	28.0	3.75
4572	PAR46	Screw Terminals		24833		Military-Flood	28.0	3.75
4578	PAR46	2 Contact Lugs		25005	25007	CIM-Flood	28.0	4.00
4579	PAR46	3 Contact Lugs		25009	25011	CIM-Headlamp	28.0/28.0	4.00
4580	PAR46	Screw Terminals		24859		Aircraft-Landing	28.0	3.75
4581	PAR46	Screw Terminals		24862		Aircraft-Landing	28.0	3.75
4582	PAR46	Screw Terminals		24853		Helicopter-Flood	28.0	3.75
4587	PAR36	Screw Terminals		24867		Aircraft-Taxiing	28.0	2.75
4589	PAR36	Screw Terminals		24873	24871	Aircraft/CIM-Flood	28.0	2.75
4589-1	PAR36	Slip-on Terminals			23509	Aircraft/CIM-Flood	28.0	2.75
4591	PAR36	Screw Terminals		24882		Aircraft-Landing	28.0	2.75
4593	PAR36	Screw Terminals		24887		Aircraft-Refueling	28.0	2.75
4594	PAR36	Screw Terminals		24891		Aircraft-Navigation	28.0	2.75
4595	PAR36	Screw Terminals		24892		Aircraft-Navigation	13.0	2.75
4596	PAR36	Screw Terminals		24898		Aircraft-Landing	28.0	2.75
4614	PAR36	Screw Terminals		24940		Aircraft-Navigation	6.0	2.75
4626	PAR36	Screw Terminals		24964		Aircraft-Taxiing	28.0	2.75
4627	PAR36	Screw Terminals		24966		Aircraft-Flood	28.0	2.75
4635	PAR46	Screw Terminals		33284		Aircraft-Landing	16.5	3.75
4636-3	PAR46	Combination		19632	16407	Signal	14.0	3.75
4651	165mm	2 Contact Lugs		18517	41861	Auto-Headlamp-High Beam	12.8	4.80
4652	165mm	3 Contact Lugs		18518	41862	Auto-Headlamp-Low Beam	12.8/12.8	4.80
4700	PAR36	3 Screw Terminals		39906	39907	Spot/Flood	13.0/13.0	2.75
4713	PAR36	Screw Terminals			11239	Aircraft-Logo	28.0	2.75
4752	PAR36	Screw Terminals		44724		CIM-Flood	28.0	2.75
4800	PAR56	3 Contact Lugs		24973		Military-Headlamp	28.0/28.0	5.00
4811	PAR36	3 Contact Lugs		24980	24979	Military-Headlamp	28.0/28.0	3.00
4825R	PAR36	3 Screw Terminals		24981	24982	CIM-Red Lens-Stop/Tail	28.0/28.0	2.75
4860	PAR56	Waterproof Terminals		40663		Military-Headlamp	28.0/28.0	5.00
4880	PAR46	2 Contact Lugs		24995		CIM-Headlamp	28.0	4.00
4912-1	165mm	Slip-on Terminals		45110	45111	Truck-Foglamp	12.8	4.53
4913-1	165mm	Slip-on Terminals		45112	45113	Tractor-Flood	12.8	4.53
4921-1	165mm	Slip-on Terminals		45116	16195	Special	13.0	4.53
5557	PAR64	3 Screw Terminals		16152		Aircraft-Landing/Taxi	28.0/28.0	3.75
6006	PAR56	3 Contact Lugs		25114		Auto-Headlamp	6.1/6.2	5.00
6014	PAR56	3 Contact Lugs		18519	37837	Auto-Headlamp	12.8/12.8	5.00



Lamp Number	Halogen Bulb Size (in.)	Lamp Base	Product Code			Primary Application	Design Volts	Maximum Length in.
			Blister Pack	Unit Pack	Bulk Pack			
SEALED BEAM LAMPS (Continued)								
6015	PAR56	3 Contact Lugs	38416	38607		Truck-Headlamp-Heavy Duty	12.8/12.8	5.00
6045	PAR56	Screw Terminals	25153			Signal	26.0	4.50
6052	200mm	3 Contact Lugs	18521	43867		Auto-Headlamp	12.8/12.8	5.44
6053	200mm	3 Contact Lugs	18298	18002		Truck-Headlamp-Long Life	12.8/12.8	5.44
7400	PAR36	Slip-on Terminals	40190	40191		Rotating Beacon Signal	12.8	2.75
7400-1	PAR36	Screw Terminals		42385		Rotating Beacon Signal	12.8	2.75
7414Y	PAR36	Screw Terminals	39987	39988		Amber Lens-Signal	12.8	2.75
7613	PAR36	Screw Terminals	41865	41866		Emergency Building Lighting	6.0	2.75
7613-1	PAR36	Slip-on Terminals	45101	45102		Emergency Building Lighting	6.0	2.75
7672-1	PAR36	Slip-on Terminals	11421	11422		Emergency Building Lighting	6.0	2.75
H4351	⊕ 140mm	Right Angle, Plastic	22386			Auto-Headlamp-Low Beam	12.8	4.00
H4352	⊕ 140mm	Right Angle, Plastic	22387			Auto-Headlamp-High Beam	12.8	4.00
H4360	⊕ 140mm	2 Right Angle Lugs	18347	18350		Tractor	12.8	3.00
H4405	⊕ PAR36	Screw Terminals	15129			Spotlamp	12.8	2.75
H4407	⊕ PAR36	Screw Terminals		40205		Hand Lantern	12.8/12.8	2.75
H4460X	⊕ PAR36	3 Screw Terminals		17674		Tractor	12.8/12.8	2.75
H4515	⊕ PAR36	Screw Terminals	15133			Spotlamp	6.4	2.75
H4651	⊕ 165mm	2 Contact Lugs	18532	45027		Auto-Headlamp-High Beam	12.8	4.80
H4656	⊕ 165mm	3 Contact Lugs	18533	49810		Auto-Headlamp-Low Beam	12.8/12.8	4.80
H4656HO	⊕ 165mm	3 Contact Lugs	14753			Auto-Headlamp-High Output	12.8/12.8	4.80
H4666	⊕ 165mm	3 Contact Lugs	18535	22879		Auto-Headlamp-High/Low Beam	12.8/12.8	4.80
H4701	⊕ 150mm	2 Lugs	18536			Auto-Headlamp-High Beam	12.8	3.40
H4703	⊕ 150mm	2 Lugs	18538			Auto-Headlamp-Low Beam	12.8	3.40
H5001	⊕ PAR46	2 Contact Lugs	18522			Auto-Headlamp-High Beam	12.8	4.00
H5006	⊕ PAR46	3 Contact Lugs	18523			Auto-Headlamp-Low Beam	12.8/12.8	4.00
H5024	⊕ PAR56	3 Contact Lugs	19428	19559		Auto-Headlamp-High/Low Beam	12.8/12.8	5.00
H5051	⊕ 165mm	2 Contact Lugs	19411	19556		Auto-Headlamp-Long Life High Beam	12.8	4.80
H5054	⊕ 200mm	3 Contact Lugs	19429	19558		Auto-Headlamp-Long Life High/Low Beam	12.8/12.8	5.44
H5062	⊕ 165mm	3 Contact Lugs	19412	19557		Auto-Headlamp-Long Life Low Beam	12.8/12.8	4.80
H6024	⊕ PAR56	3 Contact Lugs	18525	13030		Auto-Headlamp-High/Low Beam	12.8/12.8	5.00
H6054	⊕ 200mm	3 Contact Lugs	18534	11545		Auto-Headlamp-High/Low Beam	12.8/12.8	5.44
H6054HO	⊕ 200mm	3 Contact Lugs	14752			Auto-Headlamp-High Output	12.8/12.8	5.44
H7550	⊕ PAR36	Screw Terminals	43561	43562		Hand Lantern	6.0	2.75
H7550-1	⊕ PAR36	Slip-on Terminals		23541		Hand Lantern	6.0	2.75
H7551	⊕ PAR36	Screw Terminals	43564	43565		Emergency Building Lighting	6.0	2.75
H7552	⊕ PAR36	Screw Terminals	43567			Emergency Building Lighting	6.0	2.75
H7553	⊕ PAR36	Screw Terminals	43570	43571		Emergency Building Lighting	6.0	2.75
H7554	⊕ PAR36	Screw Terminals		43574		Emergency Building Lighting	6.0	2.75
H7555	⊕ PAR36	Screw Terminals	44642	44643		Emergency Building Lighting	12.0	2.75
H7556	⊕ PAR36	Screw Terminals	44924	44925		Emergency Building Lighting	6.0	2.75
H7557	⊕ PAR36	Screw Terminals	12720	12721		Emergency Building Lighting	12.0	2.75
H7600	⊕ PAR36	Screw Terminals	42841	42842		Rotating Beacon Signal	12.8	2.75
H7604	⊕ PAR36	Screw Terminals	43576	43577		Spotlamp	12.8	2.75
H7606	⊕ PAR36	Screw Terminals	14616	43580		Tractor-Flood	12.8	2.75
H7607	⊕ PAR36	Screw Terminals	19276	17672		Tractor-Flood	12.8	2.75
H7609	⊕ PAR46	Screw Terminals	14617	43583		Tractor-Flood	12.8	3.75
H7610	⊕ PAR36	Screw Terminals	14618	43586		Tractor-Trapezoidal Beam	12.8	2.75
H7612	⊕ PAR46	Screw Terminals	49695			Foglamp	12.8	3.75
H7614	⊕ PAR36	Screw Terminals	49731	49732		Flood	12.8	2.75
H7616	⊕ PAR36	Screw Terminals	42838	42839		Spotlamp	12.8	2.75



Lamp Number	Halogen (1)	Bulb Size	Lamp Base	Product Code			Primary Application	Design Volts	Maximum Length in.
				Blister Pack	Unit Pack	Bulk Pack			
SEALED BEAM LAMPS (Continued)									
H7619	⊕	PAR46	Screw Terminals	14619	43589		Tractor-Trapezoidal Beam	12.8	3.75
H7621-1	⊕	PAR46	Slip-on Terminals	45057	45058		Truck-Special Service	12.8	3.75
H7635	⊕	PAR46	Screw Terminals	43591	43592		Spotlamp	12.8	3.75
H7635X	⊕	PAR46	Screw Terminals		18022		Spotlamp with Shield	12.8	3.75
H7680X	⊕	PAR46	Screw Terminals	26694	26695		Halogen Infrared-Spotlamp Long Life	13.0	3.75
H7680HIR	⊕	PAR46	Screw Terminals	17894	17890		Halogen Infrared-Spotlamp	13.0	3.75
H7913HIR	⊕	165mm	2 Contact Lugs	23251	23250		Tractor-Halogen Infrared	12.8	4.80
H7921-1	⊕	165mm	Slip-on Terminals	13425	13426		Special	12.8	4.53
H7935-1	⊕	165mm	Slip-on Terminals	14890	14892		Spotlamp	12.8	4.53
H9405	⊕	150mm	2 Right Angle Lugs	15767	15763		Spotlamp	12.8	3.00
H9406	⊕	150mm	2 Right Angle Lugs	15769	15768		Tractor-Flood	12.8	3.00
H9411	⊕	150mm	2 Right Angle Lugs	15771	15770		Tractor-Trapezoidal Beam	12.8	3.00
H9414	⊕	150mm	2 Right Angle Lugs		15772		Tractor-Medium Flood	12.8	3.00
H9415	⊕	150mm	2 Right Angle Lugs	16484	16483		Auto-Foglamp	12.8	3.00
H9415A	⊕	150mm	2 Right Angle Lugs	17988			Auto-Amber Lens-Foglamp	12.8	3.00
H9420	⊕	150mm	2 Right Angle Lugs	16976	16978		Auto-Driving Lamp	12.8	3.00
H9421	⊕	150mm	2 Right Angle Lugs	16482	16204		Truck-Special	12.8	3.00
HP4651	⊕	165mm	2 Contact Lugs	18541			Plastic-Auto-Headlamp	12.8	4.80
HP4656	⊕	165mm	3 Contact Lugs	18540			Plastic-Auto-Headlamp	12.8/12.8	4.80
HP6054	⊕	200mm	3 Contact Lugs	18544			Plastic-Auto-Headlamp	12.8/12.8	5.44
Q4509	⊕	PAR36	Screw Terminals	22109			Aircraft-Landing	13.0	2.75
Q4554	⊕	PAR46	Screw Terminals	37706			Aircraft-Taxiing	28.0	2.63
Q4559	⊕	PAR64	Screw Terminals	40579			Aircraft-Landing	28.0	3.75
Q4559X	⊕	PAR64	Screw Terminals	42552			Aircraft-Landing-High Output	28.0	3.75
Q4566	⊕	PAR46	Screw Terminals	41097			Aircraft	28.0	3.32
Q4597	⊕	PAR46	Screw Terminals	37372			Aircraft-Flood	28.0	3.32
Q4629	⊕	PAR64	Screw Terminals	40577			Aircraft-Logo	28.0	4.81
Q4631	⊕	PAR36	Screw Terminals	34537			Aircraft-Landing	13.0	2.75
Q4632	⊕	PAR36	Screw Terminals	39112			Aircraft-Logo	13.0	2.75
Q4681	⊕	PAR46	Screw Terminals	36271			Aircraft-Landing	28.0	2.63



GENERAL INFORMATION

Lamp Locator 8-2
Bases Identification 8-4
Light Center Length 8-4
Filament Identification 8-4
Introduction 8-5
General Information 8-6
ANSI-Coded GE Projection Lamps Index 8-7

QUARTZLINE® PROJECTION LAMPS

Mini Multi-Mirror® Quartzline® 8-7
Multi-Mirror® Quartzline® 8-10
Quartzline® 8-11

INCANDESCENT PROJECTION LAMPS

Incandescent Lamps 8-13

PULSED XENON ARC LAMPS

PXA Lamps 8-15

HIGH-INTENSITY ARC LAMPS

Gemini™ 8-15
MARC™ 8-15

PHOTOFLOOD LAMPS

Photoflood Lamps 8-16

SUBSTITUTE LAMP GUIDE

Substitute Lamp Guide 8-17



LAMP LOCATOR

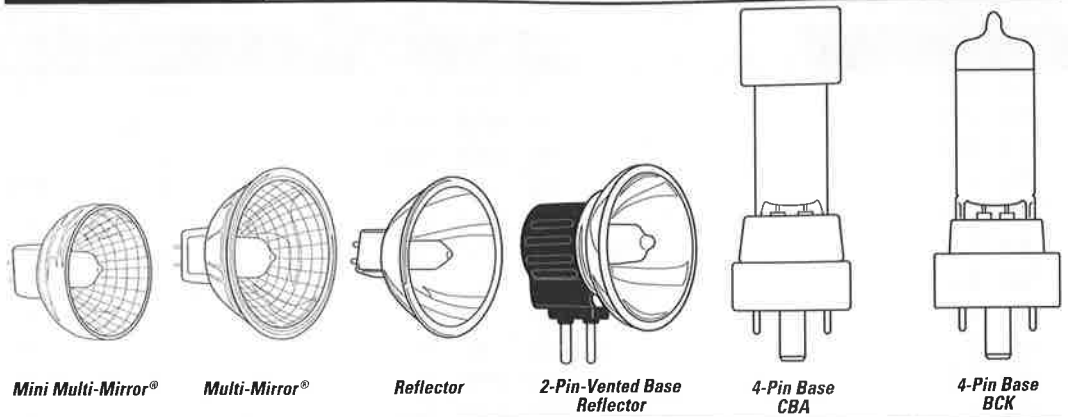

Mini Multi-Mirror®

Multi-Mirror®

Reflector

2-Pin-Vented Base Reflector

4-Pin Base CBA

4-Pin Base BCK

Quartzline® Projection Lamps

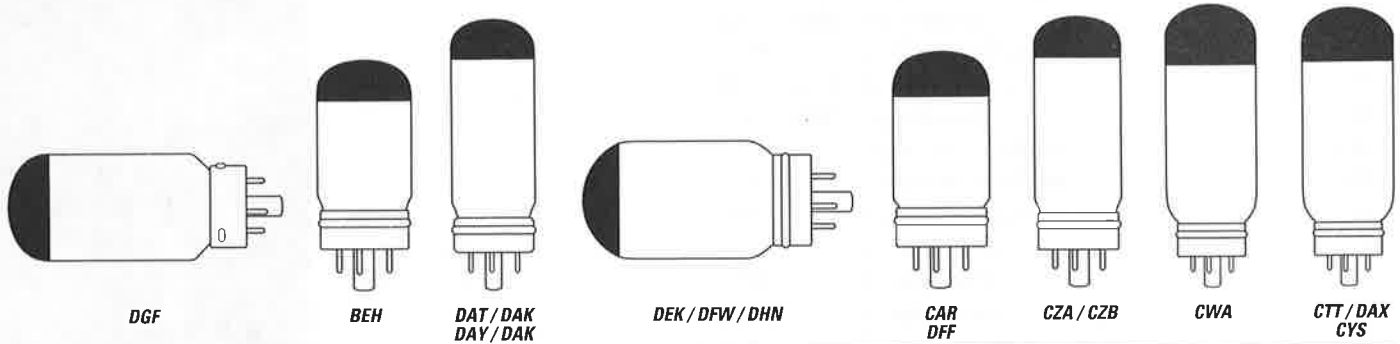

DGF

BEH

DAT / DAK
DAY / DAK

DEK / DFW / DHN

CAR
DFF

CZA / CZB

CWA

CTT / DAX
CYS

Incandescent Projection Lamps / 4-Pin Base

Incandescent Projection Lamps / 4-Pin Base - Proximity Reflector

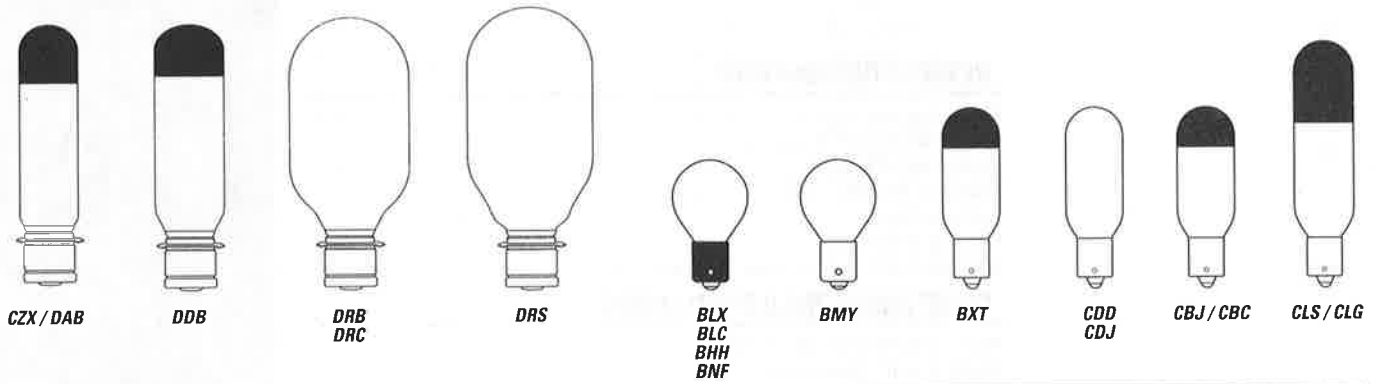

CZX / DAB

DDB

DRB
DRC

DRS

BLX
BLC
BHH
BNF

BMY

BXT

CDD
CDJ

CBJ / CBC

CLS / CLG

Incandescent Projection Lamps / Medium Prefocus Base

Incandescent Projection Lamps / Double Contact Bayonet Base

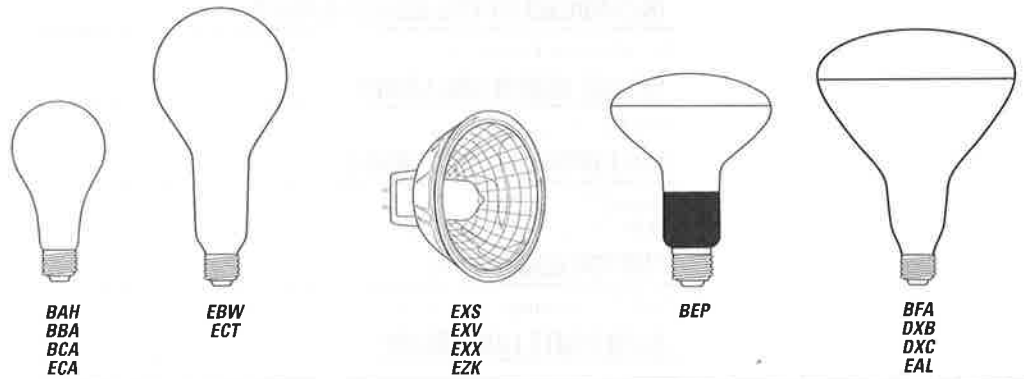

BAH
BBA
BCA
ECA

EBW
ECT

EXS
EXV
EZK

BEP

BFA
DXB
DXC
EAL

Standard Photofloods

Reflector Photofloods

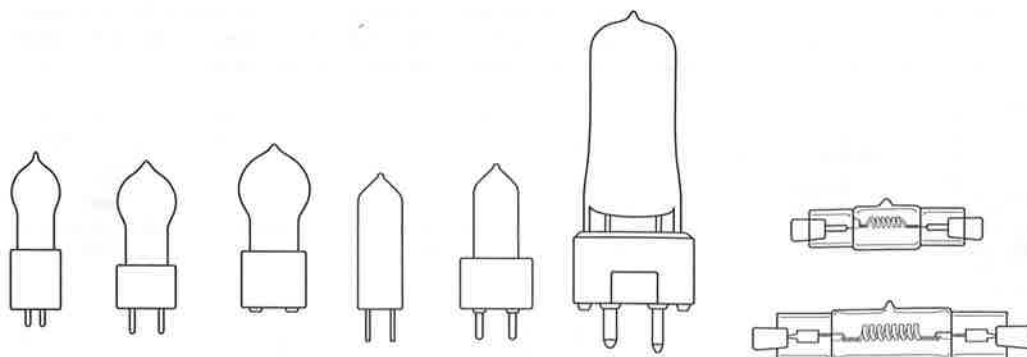

G-6 G5.3 G-7 GZ9.5 G-7 DYP T-4 GY6.35 T-4 GZ9.5 T-6 GZ9.5

Double-Ended

Quartzline® Projection Lamps - Single-Ended

Quartzline® Projection Lamps

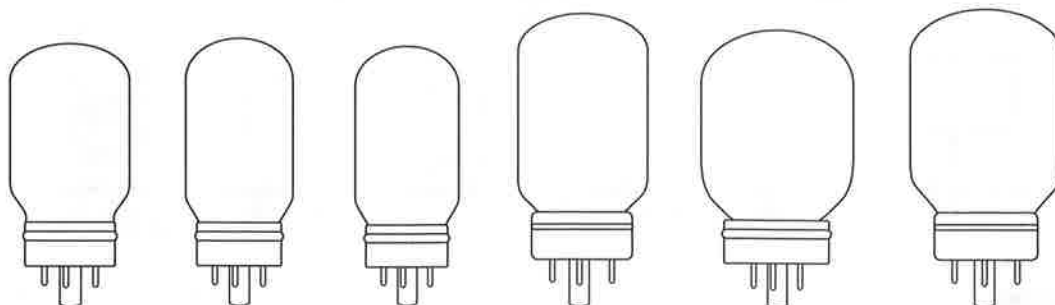

DFN / DFC DFA DCH / DJA / DFP DGB / DMD DLD / DFZ DKR DJL

Incandescent Projection Lamps / 4-Pin Base - Focusing Reflector

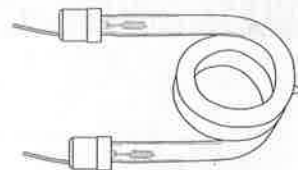

PXA-50
PXA-80



PXA-44
PXA-45

Pulsed Xenon Arc Lamps

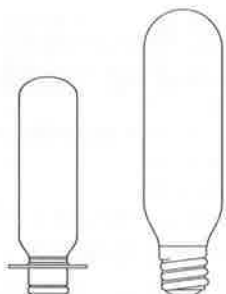

DGS DPT

Incandescent Projection Lamps / Misc.

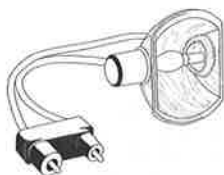

Gemini 300
EZG

High-Intensity Gemini™ Arc Lamps



MARC 300 / 16
EZM



MARC 350 / 16T
EZT

High-Intensity MARC™ Arc Lamps

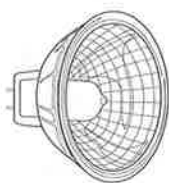

DDF
EJL
ELC
ELH
ENH
ESD
ESJ
EVV
EYA



EJV

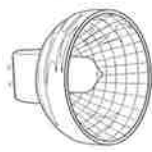

EZF/EZJ



PH/211
PH/212
PH/213
BBA



PH/140
PH/1400



PH/111A

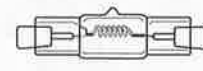

FAL
FFJ

Enlarger & Printer Lamps



BASE IDENTIFICATION

Typical bases used on Projection lamps in this catalog are shown below along with their names and common abbreviations. Where the base is an ANSI standard type, the ANSI reference code (which is the same as the IEC base code) is also shown. ANSI reference codes conform to American National Standard C81.10, C81.30, C81.50 specifications for electric lamp bases and lampholders. Illustrations are not to scale.

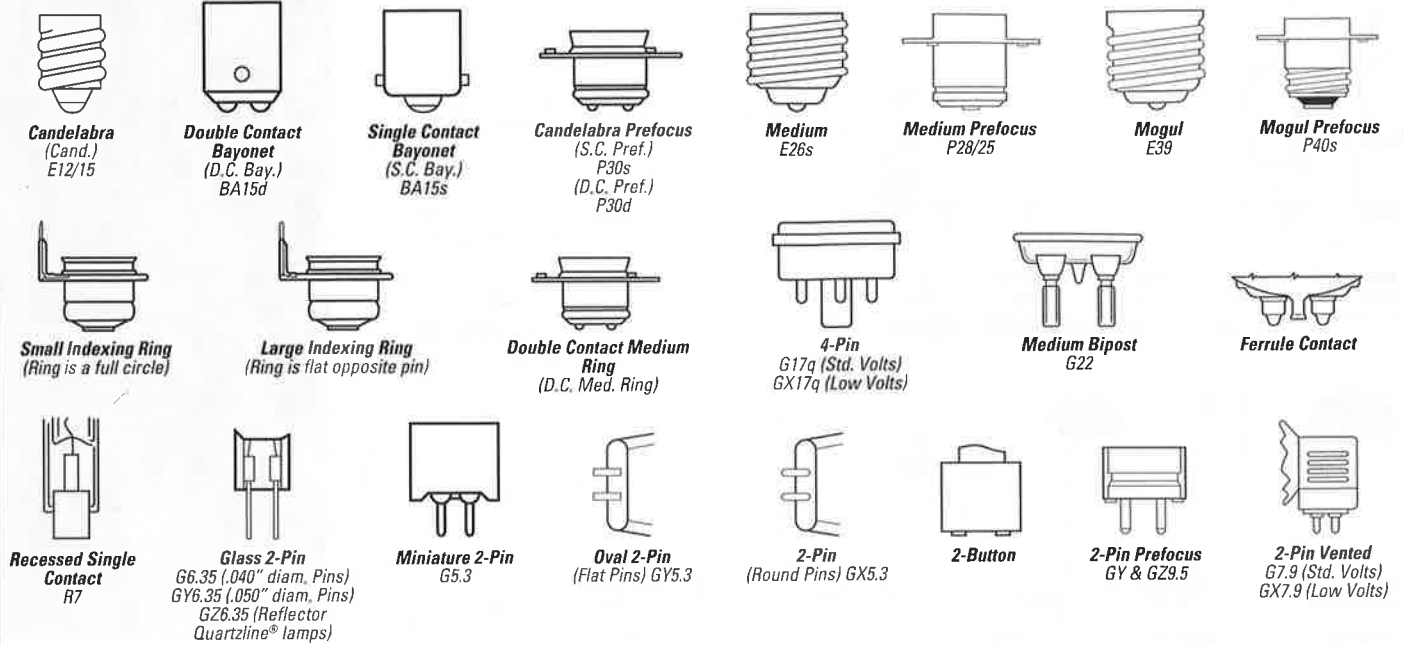

LIGHT CENTER LENGTH (LCL)

Light center length is the distance from the center of the light source to the point indicated below for the lamp base used. It is a measurement to which the lamp is designed and is subject to the manufacturer's tolerances.

Base Type	LCL Reference	Base Type	LCL Reference
All Screw Bases	Bottom base contact	2-Button	Top of ceramic base to top of filament coil
Medium Prefocus	Top of base fins	2-Pin (MR reflector)	Front face of reflector rim
Mogul Prefocus	Top of base fins	2-Pin Vented	Bottom of base ceramic to lamp optical axis
S.C. or D.C. Bayonet	Top of base pins	4-Pin	Bottom edge of base cup
2-Pin Prefocus	Bottom of base ceramic	Locking 4-Pin	Bottom edge of base cup
Miniature 2-Pin	Bottom of base pins	S.C. or D.C. Prefocus	Plane of locating bosses on prefocus collar
2-Pin	Bottom of base pins	D.C. Medium Ring	Plane of locating bosses on prefocus collar
Glassal 2-Pin	Bottom of base pins	Indexing Ring	Top of indexing ring

FILAMENT IDENTIFICATION

The configuration of the filament in all tungsten filament lamps (including Quartzline®) is identified by a prefix letter and a suffix number. The prefix letter indicates whether the filament wire is a single coil (C) or a coiled coil (CC). The suffix number indicates the form or arrangement of the filament coil or coils on its support structure. Illustrations are not to scale.

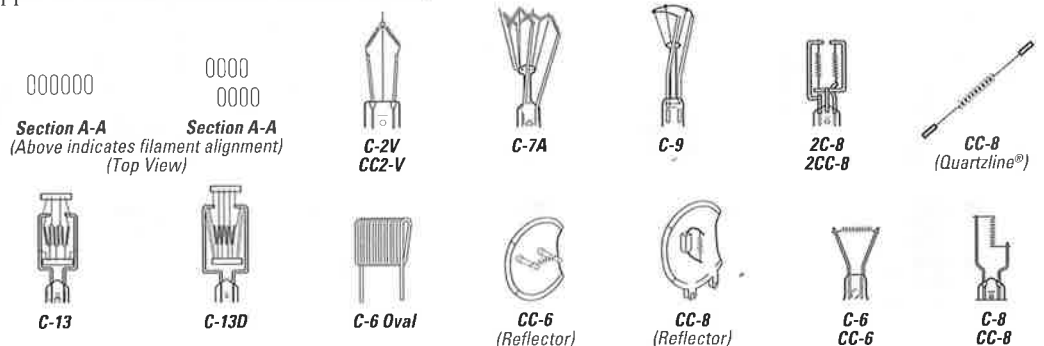



INTRODUCTION

General Electric Projection Lamps are designed for a wide variety of applications... and now extending well beyond the original picture-taking and audio-visual projection uses into such fields as: fiber optical systems, graphic arts, video camera lights, airport runway markers, micrographics, photo printers and enlargers, medical/scientific instruments, and many others.

The information contained in this section is designed to provide end-users, equipment manufacturers, and lamp distributors and dealers with:

- Essential technical data on GE Projection Lamps (Quartzline®, Incandescent, MARC™ and Flash)
- Suggested substitutes for improved performance or discontinued lamps
- Cross-reference of imported lamp codes to GE order codes
- Lamp-to-equipment guide for 8mm, 16mm, slide overhead, microfilm readers, printers, enlargers, film viewer and sound lamps

The majority of Projection Lamps described herein are characterized by:

- Precisely manufactured, tailored filaments... maximizing source brightness, optimum performance in precision optical devices
- High light-generating efficacy (lumens per watt)... to help minimize power requirements and heat generation
- Prefocus type bases, or rim-reference mounting for Multi-Mirror® lamps... to position the filament accurately in relation to the associated optics
- Design life Rated Average Life (per ANSI Standard)
- Lamps with internal or external reflectors (as in Multi-Mirror® and some 4-pin projection lamps)... permitting high-efficiency illumination system designs with a minimum of additional optical control elements

Manufacturers and designers of equipment requiring lamps should select lamps of established design whenever possible for maximum economy, as well as for ease of replacement by their customers through regular trade channels. General Electric offers application engineering assistance to all customers for applying lamps in product design. Contact your local GE Lamp Representative for additional information or assistance.

CAUTION NOTICE

As with any product, certain precautions should be observed in the handling and use of GE Projection Lamps to provide optimum performance and safety. These are given in the Caution Notices that are printed on page 8-13 for Quartzline® Projection Lamps, and on page 8-17 for ANSI-Coded Incandescent Photo Lamps.

Important Notice

This catalog contains accumulated data to February 1999. Additional information is constantly being uncovered through research and testing, which may modify the data given herein. This is particularly true of newer lamps. For the latest lamp design data and information, contact your General Electric Lamp Representative.

The data and suggested applications contained in this catalog, as well as any additional information our representative may be able to furnish, are for general information only and are not intended and should not be taken as representations or warranties as to the suitability of a lamp for any particular application or use in any particular equipment, nor are our representatives authorized to make any such representations or give any such warranties. Applications and conditions of use are many and varied, and beyond our control. We cannot possibly have the same degree of knowledge that the purchaser has with respect to the design of his equipment and the conditions of its use. Therefore, it is up to the purchaser to make his own determination as to the suitability of a lamp for his intended application or use and to assume the responsibility for that determination.

General Electric desires to supply the best possible products at all times. For this reason, General Electric reserves the right to make changes in its products when it believes such changes will improve its products.



GENERAL INFORMATION

General Electric Projection Lamps are briefly described in the alphabetical lamp index (pages 8-7 – 8-9). More extensive descriptive and performance data are found in the lamp tables, which are organized as “families” of lamps with one or more features in common – such as Multi-Mirror® Quartzline®, Single-Ended Quartzline®, 4-pin Based Incandescent, Photoflood, etc. Within each table, lamps are listed alphabetically by GE Lamp Code. The footnotes on each page provide supplementary information. The following paragraphs explain the data columns in the tables.

GE Lamp Code

This is a 3-letter or letter-number code uniquely identifying the lamp for ordering purposes. In some instances, lamps with 3-letter (ANSI) codes are offered in more than one design voltage, in which case the voltage required should also be specified when ordering.

ANSI Codes

These are 3-letter codes assigned by the American National Standards Institute. They provide a system of assuring mechanical and electrical interchangeability among similarly coded lamps from various manufacturers. General Electric uses the assigned ANSI Codes as Lamp Ordering Codes for most Projection Lamps.

Multiple-ANSI-Coded Projection Lamps

Some GE Projection Lamps have an ordering code comprising two or more 3-letter ANSI codes – such as EM/EKS and DYS/DYV/BHC. The first code is the ANSI code, the secondary codes identify which the multiple-coded lamp can directly replace. Only the first code appears on the lamp itself. Multiple-coded lamps are so-designated by General Electric for the convenience of the customer.

Primary Application

This column indicates the original primary application of the lamp. However, lamps can be, and often are, used in other types of equipment where their design features meet the requirements of the application.

Watts (or Amps)

This column shows the rated power consumption (watts) of the lamp at its design voltage. A few lamps, in Tables 16 & 18, are rated in terms of current (amperes) drawn initially at their rated voltage. The watts shown for the lamps in Table 8 are the approximate initial values for operation at rated amperes.

Volts

The voltage shown is the design voltage of the lamp, on which the life and wattage ratings are based. Lamps for which 115-120 is shown in the Volts column are designed at 118 volts. Lamps are available only in the design voltage(s) shown. When ordering lamps listed for more than one voltage, be sure to specify the voltage required. (Supply voltage variation can significantly affect lamp life.)

Rated Average Life

Average life ratings of Projection Lamps are based on closely controlled laboratory tests of lamps, at their rated voltage, over a long period of production time. Rated Average Life is not necessarily the same as service life; mechanical shock and vibration, voltage fluctuation, temperature and other environmental factors may result in shorter service life. As with any average value, some individual lamps may operate longer, and some may operate shorter, than their Rated Average Life. (Supply voltage variation can significantly affect lamp life.)

Typical Working Distance

For Multi-Mirror® and other reflector Quartzline® lamps and MARC™ lamps, the Working Distance shown is the distance from the front surface of the reflector rim to the film plane, in the optical system for which the lamp was first designed. In most cases, it provides a uniform plane of light for the intended aperture.

Bulb

Projection Lamp bulb designations use a combination of letters and numerals to indicate bulb shape and maximum diameter in eighths of an inch. For example: a “T-12” bulb is Tubular-shaped and 12-eighths of an inch, or 1 1/2” in diameter. Illustrations of typical Projector Lamps and their respective bulb designations are shown in the tables of lamp families, pages 8-9 – 8-16.

Base

Projection Lamp base illustrations appear on page 8-4, along with their common trade names and abbreviations, plus their letter-number ANSI/IEC designations where applicable.

Filament

Typical filament configurations for Projection Lamps are shown on page 8-4, along with an explanation of the filament designation system.

Source Size

This is defined as the dimensions of the rectangular area, centered on the lamp axis, within which all luminous parts of the filament lie, when viewed perpendicular to the axis of the filament coil or to the plane of C-13 and C-13D filaments.

Operating Position

For good performance, lamps must be used within specified limitations on operating position. The following abbreviations are used in the lamp tables to indicate these limits:

- BD = Base Down, Operate only vertical, base down.
- BU = Base Up, Operate only vertical, base up.
- BDTH = Base Down To Horizontal. Do not operate with base above horizontal.
- Horiz = Horizontal, Operate only in horizontal position.

Light Center Length (LCL)

This dimension defines the location of the filament in relation to the base. It is measured from the geometric center of the filament to a specified point on, or plane through, the base. Light Center Length is subject to manufacturing tolerances. Reference points/planes from which LCL is measured are tabulated on page 8-4 for the various styles of lamp bases.

Maximum Overall Length (MOL)

This dimension include the lamp bulb and all rigid parts of the base. Since the listed lengths include maximum tolerances, actual lamps are generally slightly shorter.

Approximate Initial Lumens

The value shown is based on spherical photometry, at rated voltage, of lamps that have been seasoned for approximately 15% (or minimum of 2 hours) or more of their rated average life.

Approximate Color Temperature

The radiation within the visible spectrum from tungsten filament lamps is similar in spectral distribution to that from a “blackbody” at specific color temperatures. The Color Temperatures shown are approximate initial values in degrees kelvin (K) for lamps operated at rated voltage.

Projection Lamps



Ordering Code Description Watts Volts Bulb Base Table No. Page No.

INDEX - ANSI-CODED GE PROJECTION LAMPS

BAB (1)... Q20MR16/FL (BAB)... Large Lamp (Precise™)

40886	BAH	300	115	A-21	Medium	18	8-16
39700*	BAK	75A	4	T-5	S.C. Pref.	16	8-14
40563	BBA	250	115-120	A-21	Medium	18, 20	8-16
40564	BCA	250	115-120	A-21	Medium	18	8-16
36178	BCK	500	120	T-6 Q	4-Pin	6	8-11
29378*	BEH	150	120	T-10	4-Pin	10	8-14
30182	BEP	300	115-120	R-30	Medium	19	8-16

BFK... use BFL/BFK

29890*	BLF/BFK*	750	115-120	★T-20	Med. Pref.	13	8-14
40658	BHB	250	120	MR-14 Q	2-Pin Ven.	5	8-11

BHC... use DYS/DYC/BHC

29212	BHD/BHF	100	20	S-11	S. C. Bay.	14	8-14
-------	---------	-----	----	------	------------	----	------

BHF... use BHD/BHF

29140	BLC	30	115-125	S-11	D. C. Bay.	15	8-14
30232	BLK	30	120-130	S-11	Cand.	18	8-16
29156	BLX	50	115-125	S-11	D. C. Bay.	15	8-14
29224	BMV	100	115-120	S-11	S. C. Bay.	14	8-14
32137	BNF	75	115-125	S-11	D. C. Bay.	15	8-14
39704*	BRD	.75A	4	T-5	S. C. Bay.	14	8-14
29604	BRH	1000	120	T-5 Q	R.S.C.	9	8-12
18235*	BRJ/EVB	150	15	T-3 1/2	G6.35	7	8-11,12
39705	BRK	.75A	4	T-5	S. C. Pref.	16	8-14
18234	BRL	50	12	T-3 1/2	G6.35	7	8-11,12
38675	BVE	600	120	T-6 Q	2-Pin Pref.	7	8-11,12
30421	BXB*	4A	8.5	T-8	S. C. Pref.	16	8-14
30418*	BXJ	4A	8.5	T-8	S. C. Bay.	14	8-14
29179	BZW	50	115-125	T-8	S. C. Bay.	14	8-14
29525	CAL	300	120	T-10	4-Pin	11	8-13
29380	CAR	150	120	T-10	4-Pin	11	8-13
29171	CAX	50	115-125	T-8	D. C. Bay.	15	8-14
29169	CAX	50	130	T-8	D. C. Bay.	15	8-14
36117*	CBA	500	120	T-6 Q	4-Pin	6	8-11

CBS... use CBX/CBS

29208	CBX/CBS	75	115-125	T-8	D. C. Bay.	15	8-14
29257	CDD	100	120	T-8	S. C. Bay.	14	8-14
29266	CDJ	100	115-125	T-8	D. C. Bay.	15	8-14
29244	CEB	100	115-125	T-8	D. C. Bay.	15	8-14
43330	CEM	120	120	T-8	S. C. Bay.	14	8-14
29248*	CJX*	100	230	T-8	D. C. Bay.	15	8-14

CLG... use CLS/CLG

29494	CLS/CLG	300	120-125	T-8 1/2	S. C. Bay.	14	8-14
29346	CTL	150	115-125	T-10	Med. Pref.	13	8-14
29664	CZA/CZB	500	120	T-10	4-Pin	11	8-13

CZB (1)... use CZA/CZB

29677	CZX/DAB	500	115-120	★T-10	Med. Pref.	13	8-14
-------	---------	-----	---------	-------	------------	----	------

Ordering Code Description Watts Volts Bulb Base Table No. Page No.

INDEX - ANSI-CODED GE PROJECTION LAMPS

DAB... use CZX/DAB

40214	DAT/DAK	400	120	T-10	4-Pin	10	8-13
29695	DAY/DAK	500	120	★T-10	4-Pin	10	8-13
29360	DCA	150	21	T-12	4-Pin	12	8-13
29364	DCH/DJA/DFP	150	120	T-12	4-Pin	12	8-13
29836	DDB	750	125	★T-12	Med. Pref.	13	8-14
43986	DDF	55	17	MR-16 Q	2-Pin	3, 20	8-10,16
43537	DDL	150	20	MR-16 Q	2-Pin	3	8-10
43206	DDM	80	19	MR-16 Q	2-Pin	3	8-10
34570	DDN	200	20	T-3 Q	R. S. C.	9	8-12
43988	DDS	80	21	MR-16 Q	2-Pin	3	8-10
43950	DED	85	13.8	MR-16 Q	2-Pin	3	8-10
29737	DEK/DFW/DHN	500	120	T-12	4-Pin	11	8-13
36122	DFE	80	30	T-12	4-Pin	12	8-13
29386	DFN/DFC	150	125	T-12	4-Pin	12	8-13

DFP... use DCH/DJA/DFP

DFW... use DEK/DFW/DHN

DFZ... use DLD/DFZ

29730*	DGF	500	120	T-12	4-Pin	10	8-13
29875*	DGH	750	120	★T-12	Med. Pref.	13	8-14
29911*	DGS	1000	115-120	★T-12	D. C. Med. Ring	17	8-14

DHN... use DEK/DFW/DHN

29984*	DHT*	1200	115-120	★T-12	Med. Pref.	13	8-14
--------	------	------	---------	-------	------------	----	------

DJA... use DCH/DJA/DFP

29338	DJL	150	120	T-14	4-Pin	12	8-13
44854	DJT	50	13.8	MR-16 Q	2-Pin	3	8-10
40216	DLD/DFZ	80	30	T-14	4-Pin	12	8-13

DLG... use DLS/DLG/DHX

29366	DLS/DLG/DHX	150	22	T-14	4-Pin	12, 20	8-13,16
40161	DNE	150	120	MR-16 Q	2-Pin Ven.	5	8-11
39742	DNF	150	21	MR-16 Q	2-Pin Ven.	5	8-11
29959	DPT	1000	115-120	★T-20	Mogul	17	8-14
18239	DRA	300	120	T-4	2-Pin Ceramic	7	8-11,12
29968	DRB	1000	115-120	★T-20	Med. Pref.	13	8-14
29979	DRC	1000	120	★T-20	Med. Pref.	13	8-14
29947	DRS	1000	120	★T-20	Med. Pref.	13	8-14
29405	DSW	200	24	T-14	4-Pin	12	8-13
30304	DVY	650	120	G-6 Q	Min. 2-Pin	7	8-11,12

DWA... use FGS/DWA

29953	DWK*	1000	230	★T-20	Med. Pref.	13	8-14
29578	DWZ	375	30	T-4 Q	R.S.C.	9	8-12
30151	DXB	500	115-120	R-40	Medium	19	8-16
30145	DXC	500	115-120	R-40	Medium	19	8-16
30313	DXN	1000	120	T-5 Q	R.S.C.	9	8-12
30347	DXX	800	230	T-4 Q	R.S.C.	9	8-12
30350	DXX	800	240	T-4 Q	R.S.C.	9	8-12
30364	DYH	600	120	G-7 Q	Min. 2-Pin	7	8-11,12
32071	DYP	600	120	G-7 Q	2-Button	7	8-11,12
33248	DYR	650	220	G-7 Q	2-Pin Pref.	7	8-11,12
33250	DYR	650	240	G-7 Q	2-Pin Pref.	7	8-11,12
19479	DYS-5	600	120	G-7	2-Pin Pf/GZ9.5	7	8-11,12
32955	DYS/DYV/BHC	600	120	G-7 Q	2-Pin Pref.	7	8-11,12

* No longer manufactured; available only until stock is depleted. ★ Heat-resistant glass bulb. Q in "Bulb" column denotes Quartzline® lamp.



Ordering Code	Description	Watts	Volts	Bulb	Base	Table No.	Page No.
INDEX - ANSI-CODED GE PROJECTION LAMPS							
DYV... use DYS/DYV/BHC							
37346	DZA	30	10.8	T-3 1/2 Q	Min. 2-Pin	7	8-11,12
37695	DZE/FDS	150	24	T-4 Q	2-Pin Pref.	7	8-11,12
DZZ... use DDJ/DZZ							
30202	EAJ	35	12	T-6 1/2	D.C. Bay.	15	8-14
30281	EAL	500	120	R-40	Medium	19	8-16
40566	EBV	500	115-120	PS-25	Medium	18	8-16
40567	EBW	500	115-120	PS-25	Medium	18	8-16
40565	ECA	250	120	A-23	Medium	18	8-16
40568	ECT	500	120	PS-25	Medium	18	8-16
30358	ECV	1000	120	PS-40	Mogul	18	8-16
41251	EFM	50	8	MR-16 Q	GZ6.35	3	8-10
41252	EFN	75	12	MR-16 Q	GZ6.35	3	8-10
41253	EFP	100	12	MR-16 Q	GZ6.35	3	8-10
41254	EFR	150	15	MR-16 Q	GZ6.35	3	8-10
37527	EHA	500	120	T-6 Q	2-Pin Pref.	7	8-11,12
14874	EHJ	250	24	T-4 Q	G6.35	7	8-11,12
23882	EJA	150	21	MR-16 Q	2-Pin	4	8-11
29150	EJL	200	24	MR-16 Q	2-Pin	3, 20	8-10,16
29151	EJM	150	21	MR-16 Q	2-Pin	3	8-10
EJN... use ELD/EJN							
32831	EJV	150	21	MR-16 Q	2-Pin	4, 20	8-11,16
32886	EJY	80	19	MR-16 Q	2-Pin	4	8-11
35200	EKE	150	21	MR-16 Q	2-Pin	3	8-10
27584	EKE/8	150	21	MR-16 Q	2-Pin	3	8-10
34865	EKN	120	17.5	MR-16 Q	2-Pin	3	8-10
35800	EKP/ENA	80	30	MR-16 Q	2-Pin	3	8-10
EKS... use ELS/ELR							
36899	EKX	200	24	MR-16 Q	2-Pin	3	8-10
36902	EKZ	30	10.8	MR-16 Q	2-Pin	3	8-10
37412	ELB	80	30	MR-16 Q	2-Pin	4	8-11
37462	ELC	250	24	MR-16 Q	2-Pin	3, 20	8-10,16
38306	ELD/EJN	150	21	MR-16 Q	2-Pin	3	8-10
38476	ELH	300	120	MR-16 Q	Oval 2-Pin	3, 20	8-10,16
EKR... use ELS/ELR							
41885	ELS/ELR	50	18	MR-14 Q	2-Pin Ven.	5	8-11
42612	EML	175	24	T-4 Q	Min. 2-Pin	7	8-11,12
40017	EMM/EKS	250	24	MR-14 Q	2-Pin Ven.	5	8-11
ENA... use EXP/ENA							
ENC... use ENW/ENC							
38685	ENG	300	120	MR-16 Q	Oval 2-Pin	3	8-10
38686	ENH	250	120	MR-16 Q	Oval 2-Pin	3, 20	8-10,16
25475	ENL	50	12	MR-16 Q	Gx5.3	3	8-10
40248	ENW/ENC	80	19	MR-16 Q	2-Pin	3	8-10
41705	ENX	360	82	MR-16 Q	Oval 2-Pin	3	8-10
19475	ENX-5	360	86	MR-16	Oval GY5.3	3	8-10
40598	ENZ	50	30	MR-16 Q	2-Pin	4	8-11
43378*	EPG	80	21	MR-14 Q	2-Pin Ven.	5	8-11
41430	EPN	35	12	MR-16 Q	2-Pin	3	8-10
19897	EPR	500	120	T-6	TF	7	8-11,12
41729	EPT	42	10.8	MR-16 Q	2-Pin	3	8-10
41882	EPV	90	14.5	MR-16 Q	2-Pin	3	8-10
41702	EPW	360	100	MR-16 Q	Oval 2-Pin/GY5.3	3	8-10
42614	EPX	90	14.5	MR-16 Q	2-Pin	3	8-10

Ordering Code	Description	Watts	Volts	Bulb	Base	Table No.	Page No.
INDEX - ANSI-CODED GE PROJECTION LAMPS							
EPZ...use Q50MR16/EPZ... Large Lamp							
19950	ERF	50	14	T-3 1/2	Wedge	7	8-11,12
41874	ERV	340	36	MR-16 Q	2-Pin	3	8-10
43756	ESD	150	120	MR-16 Q	Oval 2-Pin	3, 20	8-10,16
49651	ESH	85	82	MR-16 Q	Oval 2-Pin	3	8-10
11698	ESJ	85	82	MR-16 Q	Oval 2-Pin	3, 20	8-10,16
11322	ETJ	250	120	MR-16 Q	Oval 2-Pin	3	8-10
38311	ETT	1000	120	T-5 Q	R.S.C.	9	8-12
18237*	EVC	250	24	T-5	G6.35	7	8-11,12
18238	EVD	400	36	T-6	GY66.35	7	8-11,12
10099	EVV	120	6.6A	T-4 Q	2-Pin Pref.	8	8-11,12
11110	EVW	250	82	MR-16 Q	Oval 2-Pin	3, 20	8-10,16
11132	EWV	200	24	MR-16 Q	2-Pin	3	8-10
11427	EWR	150	6.6A	T-4 Q	2-Pin Pref.	8	8-12
11478	EXL	30	6.6A	T-3 1/2 Q	2-Pin Pref.	8	8-12
11482	EXM	45	6.6A	T-3 1/2 Q	2-Pin Pref.	8	8-12
12092	EXR	300	82	MR-13 Q	2-Pin	2	8-9
12503*	EXS	200	30	MR-16 Q	2-Pin	3, 19	8-10,16
12003	EXV	100	12	MR-16 Q	2-Pin	3, 19	8-10,16
12095	EXW	300	82	MR-13 Q	2-Pin	2	8-9
11750	EXX	250	120	MR-16 Q	Oval 2-Pin	3, 19	8-10,16
12097	EXY	250	82	MR-13 Q	2-Pin	2	8-9
13152	EYA	200	82	MR-16 Q	Oval 2-Pin	3, 20	8-10,16
12696	EYB	360	82	T-3 1/2 Q	Min. 2-Pin	7	8-11,12
19322	EYB-5	82	86	T-3 1/2	G5.3	7	8-11,12
13617	EYH/FKT	250	120	★G-6 Q	Min. 2-Pin	7	8-11,12
13905	EYK	300	120	MR-16 Q	Oval 2-Pin	3	8-10
23522	EZA	30	6.6A	MR-16	GX5.3	3	8-10
23071	EZC	45	6.6A	MR-16	GX5.3	3	8-10
15832	EZF/EZJ	225	68	MR-13 Q	2-Pin	2, 20	8-9,16
11134	EZQ	300	35	2 1/2	Special	-	8-15
	Gemini™ 300			Dichroic Reflector	2-Pin Plug		
	(High-intensity arc)						
15477	EZK	150	120	MR-16 Q	Oval 2-Pin	3, 19	8-10,16
15243	EZL	200	30, 67V/6.6A	T-4 Q	2-Pin Pref.	8	8-12
29469	EZM	300	37.5	3"	Special	-	8-15
	(MARC-300/16)			Dichroic Reflector	2-Pin Plug		
	(High-intensity arc)						
23523*	EZP	50	6.6A	MR-16	GX5.3	3	8-10
39936	EZT	350	45	3"	Special	-	8-15
	MARC-350/16T			Dichroic Reflector	2-Pin Plug		
	(High-intensity arc)						
15213	EZW	85	82	MR-16 Q	Oval 2-Pin	3	8-10
29581	FAL	420	120	T-4 Q	R.S.C.	9, 20	8-13,16
FBD... use FBG/FBD							
33663	FBG/FBD	500	120	G-6 Q	Min. 2-Pin	7	8-11,12
29598	FCB	600	120	T-4 Q	R.S.C.	9	8-12
14876	FCR	100	12	T-3 Q	GZ6.35	7	8-11,12
13598	FCS	150	24	T-4 Q	G6.35	7	8-11,12
FDS... use DZE/FDS							
35321	FDT	100	12	T-3 Q	2-Pin Pref.	7	8-11,12
36878	FDV	150	24	T-4 Q	Glass 2-Pin	7	8-11,12
18243*	FDX	100	12	T-4	2-Pin Ceramic	7	8-11,12
29592	FFJ	600	120	T-4 Q	R.S.C.	9, 20	8-13,16
30276	FFM	420	120	T-4 Q	R.S.C.	9	8-12
47614	FHS	300	82	MR-13 Q	2-Pin	2	8-9
47914	FHX	25	13.8	MR-16 Q	2-Pin	3	8-10



Ordering Code	Description	Watts	Volts	Bulb	Base	Table No.	Page No.
---------------	-------------	-------	-------	------	------	-----------	----------

INDEX – ANSI-CODED GE PROJECTION LAMPS

FKT... use EYH/FKT							
30894	FLS	28	12	MR-11	GZ4	1	8-9
31964	FLT	25	13.8	MR-11	G-4	1	8-9
19868	FLW	300	24	T-4	GY6-35	7	8-11,12
14887	FML	50	13.8	MR-16 Q	2-Pin	3	8-10
18241	FNT	275	24	T-4	G6.35	7	8-11,12
21613	FXL	410	82	MR-16	GY5.3	3	8-10
30162	PH/111A	75	125	S-11	S.C. Bay.	20	8-16
43220	PH/140	75	120	S-14	Medium	20	8-16
40569	PH/211	75	115-125	A-21	Medium	20	8-16
40570	PH/212	150	115-125	A-21	Medium	20	8-16
40571	PH/213	250	115-125	A-21	Medium	20	8-16
43222	PH/1400	75	230	S-14	Medium	20	8-16

Ordering Code	Description	Watts	Volts	Bulb	Base	Table No.	Page No.
---------------	-------------	-------	-------	------	------	-----------	----------

INDEX – ANSI-CODED GE PROJECTION LAMPS

Gas Discharge Gemini® and MARC™

11134	Gemini 300 (EZG)	300	35	2 1/2" Dichroic Reflector	Special 2-Pin Plug	–	8-15
29469	MARC-300/16 (EZM)	300	37.5	3" Dichroic Reflector	Special 2-Pin Plug	–	8-15
39936	MARC-350/16T (EZT)	350	45	3" Dichroic Reflector	Special 2-Pin Plug	–	8-15

Pulsed Xenon Arc Lamps*

30119*	PXA-44	600	–	T-3	Special	–	8-15
30120	PXA-45	1500	–	T-3	Special	–	8-15
30124	PXA-50	4000	–	T-3	Special	–	8-15
30129	PXA-80	8000	–	T-3	Special	–	8-15

* No longer manufactured; available only until stock is depleted.

* Heat-resistant glass bulb.

Q in "Bulb" column denotes Quartzline® lamp.

GE MULTI-MIRROR® QUARTZLINE® PROJECTION LAMPS

Invented By GE For Optimized Projection System Performance.

The Multi-Mirror® and its new companion, the Mini Multi-Mirror®, are reflector halogen Quartzline® lamps with innovative GE features that result in better system efficiency, screen uniformity, lamp-to-lamp consistency and relamping convenience.

Feature	Benefit	Applications
• Dichroic reflector	• Cool light beam	• Slide Projection
• Precise rim reference	• Efficient light reflection	• Front/Rear Screen Projection
• Faceted reflector	• Quick lamp installation	• Microfilm
• Halogen Quartzline® lamp	• Accurate snap-in alignment	• Overhead Projection
	• Efficient beam for brighter image	• 16mm Movie
	• Uniform screen image	• 8mm Movie
	• Precision beam control	• Film Strip
	• Whiter and brighter light	• Enlargers/Printers
	• No bulb blackening/blistering	• Fiber Optics
	• Constant light output through life	• Medical/Scientific Instruments
	• Stable color temperature	• Video Camera Lights
		• Airport Runways
		• Display

Each GE Multi-Mirror® lamp type is optically tailored to its application. First, the appropriate type of multi-faceted reflector is determined. Then a filament tube developed, using advanced Quartzline® technology. Finally, the two are combined, using sophisticated, computerized precision-assembly techniques. The result – consistently high performance... lamp after lamp after lamp.

GE Lamp Code	Primary Application	Watts	Volts	Rated Average Life (Hours)	Typical Working Distance	Filament	Approximate Color Temperature K.	Base / ANSI
--------------	---------------------	-------	-------	----------------------------	--------------------------	----------	----------------------------------	-------------

MINI MULTI-MIRROR® QUARTZLINE®

MR-11 Faceted Dichroic Reflector, 1 3/8" (35mm) Dia., 1 3/8" (35mm) Max. Overall Length. Operate Base Down to Horizontal. Table 1.

FLT	Microfilm	28	13.8	500	–	CC-6	3050	2-pin / GZ4
FLS	Microfilm	28	12	1000	–	CC-6	3000	2-pin / GZ4

MR-13 Faceted Dichroic Reflector, 1 2/3" (35mm) Dia., 1 3/4" (35mm) Max. Overall Length. Operate Base Down to Horizontal. Table 2.

EXR	Slide projection	300	82	35	6"	CC-8	3350	2-pin / GX5.3
EXW	Slide projection	300	82	15	6"	CC-8	3450	2-pin / GX5.3
EXY	Slide projection	250	82	200	6"	CC-8	3200	2-pin / GX5.3
EZF/EZJ	Color printer	225	68	500	–	CC-8	(1)	2-pin / GX5.3
FHS	Slide projection	300	82	70	6"	CC-8	3300	2-pin / GX5.3

Projection Lamps



GE Lamp Code	Primary Application	Watts	Volts or Amps (A)	Rated Average Life (Hours)	Typical Working Distance	Filament	Approximate Color Temperature K.	Base / ANSI
MULTI-MIRROR® QUARTZLINE®								
MR-16 Faceted Dichroic Reflector, 2" Dia., 1 3/4" Max. Overall Length. Operate Base Down to Horizontal except as noted. Table 3.								
DDF	Enlarger, projection	55	17	300	2 3/16"	CC-6	3100	2-pin / GX5.3
DDL	Microfilm	150	20	500	7 3/4"	C-6	3150	2-pin / GX5.3
DDM	Slide projection	80	19	50	6"	CC-6	3350	2-pin / GX5.3
DDS	Microfilm	80	21	1000	6 1/2"	CC-6	3125	2-pin / GX5.3
DED	Microfilm	85	13.8	1000	6 1/2"	C-6	3150	2-pin / GX5.3
DJT	Microfilm	50	13.8	1000	6"	CC-6	3150	2-pin / GX5.3
EFM	8mm projection	50	8	50	1 1/4"	C-6	3300	2-pin / GZ6.35 (3)
EFN	8mm projection	75	12	50	1 1/4"	CC-6	3350	2-pin / GZ6.35 (3)
EFP	8mm projection	100	12	50	1 1/4"	CC-6	3350	2-pin / GZ6.35 (3)
EFR	8mm projection	150	15	50	1 1/4"	CC-6	3350	2-pin / GZ6.35 (3)
EJL	16mm, Color printer	200	24	50	1 1/4"	CC-6	3400	2-pin / GX5.3
EJM	8mm projection	150	21	40	1 1/2"	CC-6	3350	2-pin / GX5.3
EKE	8mm projection, fiber optics	150	21	250	1 3/4"	CC-6	3250	2-pin / GX5.3
EKE/8	8mm projection	150	21	200	1 3/4"	C-8	3200	2-pin / GX5.3
EKN	Microfilm	120	17.5	130	1 1/2"	CC-6	3200	2-pin / GX5.3
EKP/ENA	8mm projection	80	30	25	1 3/4"	CC-6	3350	2-pin / GX5.3
EKX	Microfilm	200	24	25	5 1/2"	CC-6	3400	2-pin / GX5.3
EKZ	16mm projection	30	10.8	200	1 1/2"	C-6	3100	2-pin / GX5.3
ELC	Fiber optics, color printer	250	24	50	1 1/4"	CC-6	3400	2-pin / GX5.3
ELC/C*	Color printer	250	24	50	1 1/4"	CC-6	3400	2-pin / GX5.3
ELD/EJN	Microfilm	150	21	40	6 1/2"	CC-6	3350	2-pin / GX5.3
ELH	Slide projection	300	120	35	6"	CC-8	3350	Oval 2-pin / GY5.3
ENG	Slide projection	300	120	15	6"	CC-8	3450	Oval 2-pin / GY5.3
ENH	Slide projection	250	120	175	6"	CC-8	3250	Oval 2-pin / GY5.3
ENL	Fiber optics, display lighting	50	12	4000	1 1/2"	C-6	3050	2-pin / GX5.3
ENW/ENC	8mm projection	80	19	200	1 3/4"	CC-6	3200	2-pin / GX5.3
ENX	Overhead projection	360	82	75	11 3/4"	CC-8	3300	Oval 2-pin / GY5.3
ENX-5	Overhead projection	360	86	75	—	CC-8	3300	Oval GY5.3
EPK	8mm projection	80	30	18	1 3/4"	CC-6	3350	2-pin / GX5.3
EPN	8mm projection	35	12	50	1 1/8"	C-6	3300	2-pin / GX5.3
EPT	Fiber optics	42	10.8	10,000	1 1/2"	C-6	2900	2-pin / GX5.3
EPV	Microfilm	90	14.5	500	6 1/8"	CC-6	3150	2-pin / GX5.3
EPW	Overhead projection	360	100	75	11 3/4"	CC-8	3250	Oval 2-pin / GY5.3
EPX	Microfilm	90	14.5	500	6 1/2"	CC-6	3150	2-pin / GX5.3
EPZ*	Microfilm	50	13.8	1000	4 1/4"	CC-6	3150	2-pin / GX5.3
ERV	Overhead projection	340	36	75	11 3/4"	CC-8	3300	2-pin / GX5.3
ESD	Enlarger, projection	150	120	12	1 3/4"	CC-8	3350	Oval 2-pin / GY5.3
ESH	Filmstrip projection	85	82	250	6"	CC-8	2950	Oval 2-pin / GY5.3
ESJ	Enlarger, projection	85	82	40	1 3/4"	CC-8	3350	Oval 2-pin / GY5.3
ETJ	Fiber optics	250	120	175	1 1/2"	CC-8	3300	Oval 2-pin / GY5.3
EVW	Overhead projection (4)	250	82	50	11 3/4"	CC-8	3300	Oval 2-pin / GY5.3
EWf	Overhead projection (4)	200	24	50	11 3/4"	CC-8	3300	2-pin / GX5.3
EXP	Video Camera	35	12	50	—	CC-6	3300	GX5.3
EXS*	Camera light (2)	200	30	50	—	CC-6	3300	2-pin / GX5.3
EXV	Camera light (2)	100	12	50	—	CC-6	3350	2-pin / GX5.3
EXX	Camera light (2)	250	120	25	—	CC-8	3300	Oval 2-pin / GY5.3
EYA	Enlarger	200	82	50	—	CC-8	3300	Oval 2-pin / GY5.3
EYK	16mm projection	300	120	60	1 1/4"	CC-8	3300	Oval 2-pin / GY5.3
EZA	Airport	30	6.6A	1000	—	C-8	2900	2-pin / GX5.3
EZC	Airport	45	6.6A	1000	—	C-8	2950	2-pin / GX5.3
EZH	Fiber optics	20	12	3000	—	CC-6	3000	GX5.3
EZK	Camera light (2)	150	120	200	—	CC-8	3200	Oval 2-pin / GY5.3
EZP*	Airport	50	6.6A	2000	—	C-8	2950	2-pin / GX5.3
EZW	Filmstrip	85	82	1000	5 1/2"	CC-8	2850	Oval 2-pin / GY5.3
FHX	Microfilm	25	13.8	250	4 1/4"	CC-6	3200	2-pin / GX5.3
FML	Microfilm	50	13.8	1000	8 7/16"	CC-6	3150	2-pin / GX5.3
FXL	Overhead projection	410	82	38	11 3/4"	CC-8	3300	Oval 2-pin / GY5.3

* No longer manufactured; available only until stock is depleted.

Projection Lamps



GE Lamp Code	Primary Application	Watts	Volts	Rated Average Life (Hours)	Typical Working Distance	Filament	Approximate Color Temperature K.	Base / ANSI
QUARTZLINE® REFLECTOR								
MR-16 Dichroic Reflector, 2" Diameter, 1 3/4" Max. Overall Length. Operate Base Down to Horizontal. Table 4.								
EJA	Fiber optics	150	21	40	1.1"	CC-6	3350	2-pin / GX5.3
EJV	8mm, printer	150	21	40	1 3/4"	CC-6	3350	2-pin / GX5.3
EJY	Fiber optics	80	19	25	1 1/2"	CC-6	3400	2-pin / GX5.3
ELB	8mm projection	80	30	18	1 1/4"	CC-6	3400	2-pin / GX5.3
ENZ	8mm projection	50	30	25	1 1/4"	CC-6	3450	2-pin / GX5.3

GE Lamp Code	Primary Application	Watts	Volts	Rated Average Life (Hours)	Typical Working Distance	Operating Position	Filament	Approximate Color Temperature K.	Max. Overall Length (Inches)	Base / ANSI
QUARTZLINE® REFLECTOR LAMPS 2-PIN-VENTED BASE										
MR-14 (1 3/4" Diam.) or MR-16 (2" Diam.) Dichroic Reflector. Table 5.										
BHB	16mm projection	250	120	25	2 5/8"	Horiz.	CC-8	3350	MR-14	1 2/3 Std. volt / G7.9
DNE	8mm projection	150	120	12	2 3/4"	Horiz.	CC-8	3350	MR-16	1.774 Std. volt / G7.9
DNF	8mm projection	150	21	25	2 3/4"	Horiz.	CC-6	3400	MR-16	1.774 Low volt / GX7.9
ELE/ELT	8mm projection	80	30	20	3 1/4"	Horiz.	CC-6	3450	MR-14	1 2/3 Low volt / GX7.9
ELS/ELR	Microfilm	50	16	650	4 3/4"	BDTH	CC-6	3100	MR-14	1.417 Low volt / GX7.9
EMM/EKS	16mm projection	250	24	50	2 5/8"	BDTH	CC-6	3400	MR-14	1 2/3 Low volt / GX7.9
EPG*	8mm projection	80	21	100	3 1/4"	Horiz.	CC-8	3300	MR-14	1 2/3 Low volt / GX7.9

Note: Working Distance is from rear edge of base-pin insulating block to film plane, in optical system for which lamp was first designed. Small Base Pin is toward reflector for low-volt lamps, toward rear for 120-volt lamps.

GE Lamp Code	Watts	Volts	Bulb	Filament	Operating Position	Rated Average Life (Hours)	Light Center Length (Inches)	Max. Overall Length (Inches)	Approximate Initial Lumens	Approximate Color Temperature K.
QUARTZLINE® 4-PIN BASE										
Primary Application: Slide Projection. ANSI Base Designation: G17q. Table 6.										
BCK	500	120	T-6	C-13D**	BDTH	50	1 9/16	3 1/4	-	3200
CBA	500	120	T-6†	C-13D**	BDTH	50	1 3/4	3 5/8	-	3200

† Opaque Ceramic top on bulb **Proximity Reflector

GE Lamp Code	Watts	Volts	Rated Average Life (Hours)	Operating Position	Approximate Source Size W x H (Inches)	Filament	Approx. Initial Lumens	Approx. Color Temp. K	Light Center Length	Max. Overall Length	Bulb	Base / ANSI
QUARTZLINE® SINGLE-ENDED												
Applications: Projection, Microfilm, Studio, etc. Table 7.												
BRL	50	12	50	-	-	C-6	1,400	3400	1.17"	1.72"	T-3 1/2	G6.35
BRJ/EVB*	150	15	50	BDTH	-	C-6	5,000	3400	1.17"	1.72"	T-3 1/2	G6.35
BVE	600	120	75	BDTH	.35 x .35	C-13D**	-	3200	1 3/4"	3 1/2"	T-6	2-Pin Pf/GZ9.5
DDP	132	22	125	BDTH	.20 x .20	C-6 Oval	3,600	3300	1 5/16"	2 11/32"	T-4	2-Pin pf/GZ9.5
DRA	300	120	300	-	-	CC-6	6,900	3300	1.21"	2.34"	T-4	2-Pin Ceramic
DVY ⁵	650	120	25	BDTH	.50 x .20	CC-6	20,000	3300	1 7/16"	2.48"	G-6***	Min. 2-Pin / G5.3
DYH ⁵	600	120	75	Any	.50 x .25	CC-6	17,000	3200	1 7/16"	2 1/2"	G-7	Min. 2-Pin / G5.3
DYP	600	120	75	Horiz.	.50 x .25	CC-6	17,000	3200	1"	2 1/4"	G-7	2-Button
DYR ⁵	650	220, 240	50	Any	.45 x .45	2CC-8	16,500	3200	1 7/16"	2 1/2"	G-7	2-Pin Pf. / GZ9.5
DYS-5 Unit	600	126	150	BDTH	.45 x .45	CC-6	15,500	3200	1 7/16"	2.5"	G-7	2-Pin Pf. / GZ9.5
DYS/DYV/BHC ⁵	600	120	75	BDTH	.50 x .25	CC-6	17,000	3200	1 7/16"	2 1/2"	G-7	2-Pin Pf. / GZ9.5
DYT	80	19	25	BDTH	.20 x .10	CC-6	2,600	3350	1 1/16"	1.98"	T-3	Min. 2-Pin / G5.3
DZA	30	10.8	400	BDTH	.15 x .05	C-6	800	3100	1 1/16"	2"	T-3 1/2	Min. 2-Pin / G5.3
DZE/FDS	150	24	100	BDTH	.25 x .15	C-6 Oval	4,500	3250	1 5/16"	2 11/16"	T-4	2-Pin Pf. / GZ9.5
EHA	500	120	50	BDTH	.35 x .35	C-13D**	-	3300	1 7/16"	3"	T-6	2-Pin Pf. / GZ9.5
EHJ	250	24	50	BDTH	.30 x .15	C-6 Oval	8,000	3400	1 5/16"	2 1/4"	T-4	Glass 2-pin / G6.35
EML	175	24	125	BDTH	.21 x .19	C-6	5,000	3200	1 1/16"	2 1/8"	T-4	Min. 2-Pin / G5.3
EPR	500	120	50	-	.31 x .30	C-13D	-	3250	2.68"	1.56"	T-6	True Focus

* No longer manufactured; available only until stocks are depleted. ** Proximity reflector *** Ultraviolet absorbing bulb

5 For these tungsten halogen lamps (unless completely enclosed within a projector or other optical device), screening techniques should be used where appropriate to protect people and surroundings in case of shattering.

Projection Lamps



GE Lamp Code	Watts	Volts	Rated Average Life (Hours)	Operating Position	Approx. Source Size W x H (Inches)	Filament	Approx. Initial Lumens	Approx. Color Temp. K	Light Center Length	Max. Overall Length	Bulb	Base / ANSI
QUARTZLINE® SINGLE-ENDED												
Applications: Projection, Microfilm, Studio, etc. Table 7.												
ERF	50	14	200	—	—	CC-6	—	3200	0.5"	1.2"	T-3 1/4	Wedge
EVA	100	12	1000	BDTH	—	C-6	2,500	3350	1.17"	1.72"	T-3 1/2	GY6.35
EVC	250	24	200	Any	.27 x .14	C-6	8,400	3200	1.21"	2.22"	T-5	G6.35
EVD	400	36	50	BDTH	—	C-6	14,500	3200	1.4"	2.34"	T-6	GY6.35
EYB	360	82	75	BDTH	.30 x .20	CC-8	10,000	3300	1 1/4"	2 1/4"	T-3 1/2	Min. 2-Pin / G5.3
EYB-5 Unit	360	86	75	BDTH	.30 x .20	CC-8	—	3200	1.25"	2.25"	T-3 1/2	Min. 2-Pin / G5.3
EYH/FKT [§]	250	120	200	BDTH	.55 x .17	CC-6	6,000	3000	1 7/16"	2 1/2"	G-6	Min. 2-Pin / G5.3
EZD	125	19	2000	BDTH	.21 x .19	C-6 Oval	2,650	3050	1 1/16"	2 1/8"	T-4	Min. 2-Pin / G5.3
FBG/FBD	500	120	50	Any	.50 x .20	CC-6	13,200	3200	1 3/4"	3"	G-6*	Min. 2-Pin / G5.3
FCR	100	12	50	BDTH	.20 x .15	C-6 Oval	2,800	3300	1 3/16"	1 3/4"	T-3	Glass 2-Pin / GY6.35
FCS	150	24	50	BDTH	.25 x .15	C-6 Oval	4,500	3300	1 3/16"	2"	T-4	Glass 2-Pin / G6.35
FDT	100	12	50	BDTH	.23 x .15	C-6 Oval	2,900	3300	1 1/16"	2 1/8"	T-3	2-Pin Pf. / GZ9.5
FDV	150	24	100	Any	.25 x .15	C-6 Oval	4,300	3050	1 3/16"	2"	T-4	Glass 2-Pin / G6.35
FDX*	100	12	50	BDTH	—	C-6	2,900	3300	1.18"	1.75"	T-4	2-Pin Ceramic
FLW	300	24	50	BDTH	.34 x .23	C-6 Oval	10,200	3500	1.21"	2.15"	T-4	GY6.35 Ceramic Base
FNT	275	24	50	BDTH	.14 x .28	C-6 Oval	10,000	3400	1 5/16"	2.25"	T-4	G6.35

* No longer manufactured; available only until stocks are depleted. ** Proximity reflector *** Ultraviolet absorbing bulb

§ For these tungsten halogen lamps (unless completely enclosed within a projector or other optical device), screening techniques should be used where appropriate to protect people and surroundings in case of shattering.

GE Lamp Code	Watts	Volts	Rated Average Life (Hours)	Operating Position	Approx. Source Size W x H (Inches)	Filament	Approx. Initial Lumens	Approx. Color Temp. K	Light Center Length	Max. Overall Length	Bulb	Base / ANSI
QUARTZLINE® SINGLE-ENDED — AIRPORT												
Table 8.												
EVV	120	6.6	500	BD	.250 x .120	C-6 Oval	3,150	3200	1.54"	2 1/2"	T-4	2-Pin Pf. / GZ9.5
EWR	150	6.6	500	BD	.250 x .162	C-6 Oval	4,100	3200	1.54"	2 1/2"	T-4	2-Pin Pf. / GZ9.5
EXL	30	6.6	1000	BDTH	.053 x .130	C-8	375	2900	1"	1 3/4"	T-3 1/2	2-Pin Pf. / GZ9.5
XEM	45	6.6	1000	BDTH	.057 x .190	C-8	750	2950	1"	1 3/4"	T-3 1/2	2-Pin Pf. / GZ9.5
EZL	200	6.6	500	BD	.280 x .185	C-6 Oval	5,000	3100	1.54"	2 1/2"	T-4	2-Pin Pf. / GZ9.5

* No longer manufactured; available only until stocks are depleted. ** Proximity reflector *** Ultraviolet absorbing bulb

§ For these tungsten halogen lamps (unless completely enclosed within a projector or other optical device), screening techniques should be used where appropriate to protect people and surroundings in case of shattering.

GE Lamp Code	Primary Application	Watts	Volts	Bulb	Rated Average Life (Hours)	Approx. Source Size (Inches)	Overall Length (Inches)	Approx. Initial Lumens	Approx. Color Temp. K.
QUARTZLINE® DOUBLE-ENDED PROJECTION LAMPS									
Recessed Single-Contact Base. ANSI Designation: R7s. CC-8 Filament. Operate Any Position. Table 9.									
DDN (PH200T3/SCR)	Microfilm	200	20	T-3	100	.330 x .155	2 3/8"	5000	3150
FAL [§]	Printer, overhead	420	120	T-4	90	.35 x .17	2 5/8"	11,000	3200
FFJ [§]	Printer, overhead	600	120	T-4	85	.60 x .17	2 5/8"	17,000	3250
DWZ	Bowling score projection	375	30	T-4	1000	.35 x .18	3 1/8"	7,500	3000
DXX [§]	Copyboard, studio	800	230, 240	T-4	90	.90 x .17	3 1/8"	20,500	3200
FFM [§]	Copyboard	420	120	T-4	90	.50 x .25	3 1/8"	11,000	3200
BRH	Overhead projection	1000	120	T-5	60	.70 x .21	3 3/4"	30,000	3350
DXN [§]	Studio	1000	120	T-5*	55	.70 x .22	3 3/4"	33,000	3400
ETT (PH1000H)	Special	1000	120	T-5	70	—	3 3/4"	—	3350
FCBS	Overhead projection	600	120	T-4	120	.45 x .18	3 3/4"	17,000	3250

* Ultraviolet absorbing bulb

§ For these tungsten halogen lamps (unless completely enclosed within a projector or other optical device), screening techniques should be used where appropriate to protect people and surrounding in case of shattering.



CAUTION NOTICE

QUARTZLINE PROJECTION LAMPS

CAUTION – GENERAL ELECTRIC QUARTZLINE® (tungsten halogen) PROJECTION LAMPS OPERATE UNDER PRESSURE AT HIGH TEMPERATURE AND MAY UNEXPECTEDLY SHATTER. Protect people and surroundings from the possibility of injury or fire from hot, flying fragments with a suitable enclosure, shield, lens or screen. Do not operate equipment with lamp compartment open. Observation of the following

1. Use lamp only in equipment specifying this lamp type and which provides adequate ventilation to maintain lamp within safe operating temperatures. If in doubt, contact equipment manufacturer.
2. Operate lamp only in the position indicated by the instructions on the lamp package, or as noted in the GE catalog description of the lamp.

3. Do not operate equipment in excess of 110% of rated voltage.
4. Do not bump or bounce equipment during operation.
5. Protect lamp from moisture, scratches or abrasions. Avoid touching bulb or inside of reflector since fingerprints may affect performance.
6. Replace lamp if it blisters or prematurely darkens.
7. Replace lamp socket if deterioration of socket is noticed.

Extended direct exposure to Quartzline® Projection Lamps not enclosed in an outer glass envelope may cause ultraviolet irritation of skin and eyes. Use of a glass or plastic lens will provide adequate protection from this ultraviolet light.

To avoid electrical shock or burns, be sure power is off and lamp has fully cooled before replacing lamp.

GE Lamp Code	Primary Application	Watts	Volts	Bulb	Filament	Rated Average Life (Hours)	Operating Position	Light Center Length (Inches)	Max. Overall Length (Inches)	Approx. Initial Lumens	Approx. Color Temp. K
--------------	---------------------	-------	-------	------	----------	----------------------------	--------------------	------------------------------	------------------------------	------------------------	-----------------------

INCANDESCENT PROJECTION LAMPS

4-Pin Base. ANSI Base Designation: G17q. Table 10.

BEH*	Slide projection	150	120	T-10 (b)	2CC-8	15	BD	1 5/16	3 1/8	3500	3100
DAT/DAK	Slide projection	400	120	T-10 (g)	C-13D	25	BD	1 9/16	4	9800	3200
DAY/DAK	Slide projection	500	120, 125	★T-10 (b)	C-13D	30	BD	1 9/16	4	12500	3200
DGF*	Slide projection	500	120	T-12 (g)	C-13D†	25	Horiz.	1 3/4	4	12000	3200

4-Pin Base – Proximity Reflector. ANSI Base Designation: G17q. Table 11.

CAL	Slide, film strip	300	120	T-10 (g)	C-13	25	BD	1 9/16	4	–	3200
CAR	Slide, film strip	150	120	T-10 (b)	2CC-8	15	BD	1 5/16	3 1/8	–	3100
CTT/DAX	16mm projection	1000	115-125	★T-12 (g)	C-13D†	25	BD	1 9/16	4 5/8	–	3300
CWA	Film strip, 16mm	750	115-125	★T-12 (g)	C-13D	25	BD	1 9/16	4 5/8	–	3250
CZA/CZB	Slide projection	500	120	T-10 (g)	C-13D	25	BD	1 9/16	4	–	3300
DEK/DFW/DHN	Slide projection	500	120	T-12 (g)	C-13D†	25	Horiz.	1 3/4	3 5/8	–	3250
DFF	Slide, film strip	150	120	T-12 (g)	2-CC8	500	BD	1 5/16	3 1/32	–	2850
DLN	Film strip	750	120	★T-12 (b)	C-13D†	25	Horiz.	1 3/4	3 5/8	–	3250

* No longer manufactured; available only until stocks are depleted. ★ Heat resistant glass bulb † Collector grid (g) Gold Top (opaque) (b) Black Top (opaque)

GE Lamp Code	Primary Application	Watts	Volts	Bulb	Filament	Rated Average Life (Hours)	Operating Position	Light Center Length (Inches)	Max. Overall Length (Inches)	Focal Distance (Inches)	Approx. Color Temp. K
--------------	---------------------	-------	-------	------	----------	----------------------------	--------------------	------------------------------	------------------------------	-------------------------	-----------------------

INCANDESCENT PROJECTION LAMPS

4-Pin Base – Focusing Reflector. ANSI Base Designation: GX17q (low-volt), G17q (std. volt). Table 12.

DCA	8mm projection	150	21	T-12 (g)	CC-6	15	BDTH	1 9/16	3 9/16	1 3/4	3250
DCH/DJA/DFP	8mm projection	150	120	T-12	CC-6	15	BD	1 9/16	3 3/8	2 1/4	3150
DFA	8mm projection	150	120	T-12 (g)	CC-6	15	BD	1 9/16	3 9/16	1 3/4	3150
DFE	8mm projection	80	30	T-12	CC-8	15	BDTH	1 9/16	3 3/16	2 1/4	3400
DFN/DFC	8mm projection	150	125	T-12	CC-8	15	BDTH	1 9/16	3 3/16	2 1/4	3150
DGB/DMD	8mm projection	80	30	T-12	CC-6	15	BD	1 9/16	3 3/8	2 1/4	3400
DJL	8mm projection	150	120	T-14	CC-8	15	BDTH	1 9/16	3 1/2	1 3/4	3150
DLD/DFZ	8mm projection	80	30	T-14	CC-6	15	BDTH	1 9/16	3 1/2	1 3/4 §	3400
DLS/DLG/DHK	8mm projection	150	22	T-14	CC-6	15	BDTH	1 9/16	3 7/16	1 3/4 §	3250
DSW	8mm projection	200	24	T-14	CC-8	25	BDTH	1 9/16	3 3/8	1 3/4 §	3300

§ Dichroic reflector (g) Gold Top (opaque) (b) Black Top (opaque)

Projection Lamps



GE Lamp Code	Primary Application	Watts or Amps (A)	Volts	Bulb	Filament	Rated Average Life (Hours)	Operating Position	Light Center Length (Inches)	Max. Overall Length (Inches)	Approx. Initial Lumens	Approx. Color Temp. K
--------------	---------------------	-------------------	-------	------	----------	----------------------------	--------------------	------------------------------	------------------------------	------------------------	-----------------------

INCANDESCENT PROJECTION LAMPS

Medium Prefocus Base. ANSI Base Designation: P28/25. Table 13.

BFL/BFK*	Bowling score projection	750	115-120	★T-20 (b)	C-13	200	BD	2 3/16	5 3/4	13,500	3050
CTL	Advertising projection	150	115-125	T-10 (b)	C-13	500	BD	2 3/16	5 3/4	2600	3000
CVS/CVX	Projection	200	115-120	★T-10	C-13	50	BD	2 3/16	5 3/4	4250	3025
CZX/DAB	8mm projection	500	115-120	★T-10 (b)	C-13D	25	BD	2 3/16	5 3/4	12,500	3200
DDB	16mm projection	750	115-120	★T-12 (b)	C-13D	25	BD	2 3/16	5 3/4	19,500	3250
DGH*	Bowling score projection	750	120	★T-12 (b)	C-13D	500	BD	2 3/16	5 3/4	14,500	3050
DHT*	16mm projection	1200	115-120	★T-12 (b)	C-13D	10	BD	2 3/16	5 3/4	36,000	3400
DRB	Overhead projection	1000	115-120	★T-20	C-13	25	BD	2 3/16	5 3/4	32,000	3350
DRC	O'hd. & opaque projection	1000	120	★T-20	C-13	50	BD	2 3/16	5 3/4	30,000	3250
DRS	Overhead projection	1000	120	★T-20	C-13D	25	BD	2 3/16	5 3/4	28,500	3325
DWK	Projection & studio	1000	230	★T-20	CC-13	50	BD	2 3/16	5 3/4	23,500	3100

Single Contact Bayonet Base. ANSI Base Designation: BA15s. Table 14.

BHD/BHF	Microscope	100	20	S-11	CC-6 □	50	BDTH	1 3/8	2 3/8	2800	3100
BMV	Toy projection	100	115-120	S-11	CC-13	50	BDTH	1 3/8	2 3/8	1860	2950
BRD*	Sound reproduction	.75A	4	T-5	C-6 □	50	Any	1 1/4	2	30	—
BXJ	Sound reproduction	4A	8.5	T-8	C-8 (7)	100	BDTH	1 5/8	3 1/8	690	—
BZW	Slide projection	50	115-125	T-8	CC-2V	50	BD	1 3/8	3 1/8	850	2800
CDD	Slide projection	100	120	T-8	CC-2V	50	BD	1 3/8	3 1/8	2000	2975
CEM	Wheel align projection	120	120	T-8 (b)	2CC-8	200	BD	1 3/8	3 1/8	1950	3000
CLS/CLG	Slide projection	300	120-125	T-8 1/2 (b)	C-13	25	BD	1 3/8	4 1/8	7600	3200

Double Contact Bayonet Base. ANSI Base Designation: BA15d. Table 15.

BLC	Editor projection	30	115-125	S-11	CC-2V	50	Any	1 3/8	2 3/8	400	2775
BLX	Toy projection	50	115-125	S-11	CC-2V	50	BDTH	1 3/8	2 3/8	780	2850
BNF	Toy projection	75	115-125	S-11	CC-2V	25	BDTH	1 3/8	2 3/8	1300	2900
CAX	Optical projection	50	120-130	T-8	CC-2V	50	BD	1 3/8	3 1/8	775	2875
CBX/CBS	Slide projection	75	115-125	T-8 (b)	CC-13	50	BD	1 3/8	3 1/8	1200	2925
CDJ	Slide projection	100	115-125	T-8	CC-2V	50	BD	1 3/8	3 1/8	2000	2975
CEB	Slide projection	100	115-125	T-8	CC-13	50	BD	1 3/8	3 1/8	1850	2975
CGP/CGF	Film strip	150	115-120	T-8 (b)	2CC-8	25	BD	1 3/8	3 5/8	3500	3075
CJX	Projection	100	230	T-8	CC-13	50	BD	1 3/8	3 1/8	1650	2850
EAJ (5)	Flashtube modeling	35	12	T-6 1/2	C-6	300	Any	1 49/64	4	620	—

Single Contact Prefocus Base. ANSI Base Designation: P30s. Table 16.

BAK*	Sound reproduction	.75A	4	T-5	C-6	300	Any	1 1/8	2	30	—
BRK	Sound reproduction	.75A	4	T-5	C-8	50	Any	1 1/8	2 3/8	28	—
BXB	Sound reproduction	4A	8.5	T-8	C-8 (7)	100	BDTH	1 5/8	3 1/8	690	—

(b) Back Top (opaque) ★ Heat-resistant glass bulb (5) Two-filament lamp (7) Filament offset 3 3/16" from base axis, in plane perpendicular to plane through base axis and base pins.
 □ Base pins of lamp are approximately perpendicular to plane of lead wires. * No longer manufactured; available only until stocks are depleted.

GE Lamp Code	Primary Application	Watts	Volts	Bulb	Base	Filament	Rated Average Life (Hours)	Operating Position	Light Center Length (Inches)	Max. Overall Length (Inches)	Approx. Initial Lumens	Approx. Color Temp. K
--------------	---------------------	-------	-------	------	------	----------	----------------------------	--------------------	------------------------------	------------------------------	------------------------	-----------------------

INCANDESCENT

Miscellaneous. Table 17.

DGS*	Projection	1000	115-120	★T-12	D. C. Med. Ring	C-13D	10	BU	3 1/2	5 7/8	32000	3375
DPT	Opaque projection	1000	115-120	★T-20	Mogul	C-13	50	BD	4 3/4	9 1/16	28000	3200

(b) Back Top (opaque) ★ Heat-resistant glass bulb * No longer manufactured; available only until stocks are depleted.



PULSED XENON ARC (PXA) LAMPS FOR THE GRAPHIC ARTS

PXA (Pulsed Xenon Arc) family... designed for the Graphic Arts Industry. They pulse 120 times/second... @ 1/100th second/flash... and provide:



- High light output
- Stable color temperature (6000° K)... from ultraviolet to infrared
- Increased production
- Lower power consumption
- Lower cost operation

CAUTION NOTICE

Pulsed Xenon lamps emit high levels of ultraviolet (UV) radiation and must be completely enclosed in an inter-locked system with all walls made of UV absorbing material. The lamp must be made inoperative before the system is opened. The operator or user should never be exposed to the high level of UV radiation emitted by PXA lamps.

PXA-50 & PXA-80...

Typical helical source... small... powerful... used in ultra-small, highly efficient reflectors... on copyboards... or for platemaking.

	PXA Number	Case Quantity	Base	Power Supply	Maximum Watt	Lumens	Tube Diameter (Inches)	Maximum Overall Length (Inches)
PULSED XENON ARC LAMPS								
PXA Lamps For The Graphic Arts								
	PXA-44*	12	Wire term. - Ceramic Caps	Special Ballast	600 watts	18,000	3/8	9 1/2
	PXA-45	12	Wire term. - Ceramic Caps	Special Ballast	1500 watts	37,500	3/8	15 1/2
	PXA-50	24	Wire term. - Ceramic Caps	Special Ballast	4000 watts	125,000	3/8	4 5/8
	PXA-80	1	Wire term. - Ceramic Caps	Special Ballast	8000 watts	240,000	3/8	4 5/8

* No longer manufactured: available only until stocks are depleted.





HIGH-INTENSITY ARC LAMPS

Designed for High Brightness and Energy Efficiency. The Optimum Choices For:

- Energy efficiency - 60 lumens/watt
- Vivid, natural color rendition
- Daylight color
- Compact, high brightness arc sources
- Optically precise light beam control
- Dichroic reflector optical assembly
- Precise rim reference lamp mounting

GEMINI® AND MARC™ LAMPS

Originally designed by GE for 16mm film projectors, Gemini® and MARC™ lamps are also being used increasingly where high intensity daylight color is desired from a safe, compact, efficient light source. Gemini and MARC lamps have significantly improved light levels in such applications as medical examination, surgical illumination and follow-spot lighting equipment. The use of Gemini and MARC systems continues to grow as designers and users discover the unique advantages of these high intensity arc lamps.

ANSI Code	GE Lamp Ordering Code	Watts (Nominal)	Volts (Nominal)	Bulb	Base	Typical Working Distance	Rated Average Life [†] (Hours)	Approximate Color Temperature K.
GEMINI® AND MARC™ LAMPS								
Operating position: plane of reflector rim vertical (EZS; Base down to horizontal) Special power supply required - see below.								
	EZG Gemini 300 (EZG) (Replaces MARC 300/16A)	300	35	Quartz Arc Tube in 2" dichroic reflector	Special 2-pin polarized plug	37mm	75*	6000
	EZM MARC-300 / 16 (EZM)	300	37.5	Quartz Arc Tube in 3" dichroic reflector	Special 2-pin polarized plug	52mm	25	5500
	EZS MARC-300 / 35K (EZS)	300	37.5	Quartz Arc Tube (50 lumens/watt)	Special	-	25	5000
	EZT MARC-350 / 16T (EZT)	350	45	Quartz Arc Tube in 3" dichroic reflector	Special 2-pin polarized plug	52mm	50	5000

[†] Should not be operated for periods of less than three minutes. Short operating cycles reduce life and degrade performance.

* On GE solid state power supplies (see below). Average lamp life is 50 hours on all other GE Power supplies.

POWER SUPPLY TO OPERATE GEMINI® AND MARC™ LAMPS

For information on the special power supply used to operate these lamps, contact:

Scientecular Lab Company
98 McKinney Avenue
Central Islip, NY 11722-4120
(516) 232-3345

EG & G Electro-Optics
1330 E. Cypress Street
Covina, CA 91724-2108
(818) 967-9521 • 1-800-363-2095
Fax: (818) 967-3151

NAPS/Fortron Source
328 Ley Road, Suite 300
Ft. Wayne, IN 46808
(219) 471-1368
Fax: (219) 471-1368

Projection Lamps



GE Lamp Code	Description	Watts	Volts	Bulb	Base	Filament	Rated Average Life (Hours)	Max. Overall Length (Inches)	Approx. Initial Lumens	Approx. Color Temp. (K)
PHOTOFLOOD LAMPS										
Standard. Table 18.										
BAH	Photocopy - Inside frost	300	115	A-21	Medium	C-9	20	4 15/16	9,000	3200
BBA	No. 1 - Inside frost	250	115 - 120	A-21	Medium	C-9	3	4 15/16	8,500	3400
BCA	No. B1 - Blue - Inside frost	250	115 - 120	A-21	Medium	C-9	3	4 15/16	5,000	4800
BLK	Photocopy - Inside frost	30	120 - 130	S-11	Cand. Screw	CC-2V	50	2 1/4	400	2700
EBY	No. 2 - Inside frost	500	115 - 120	PS-25	Medium	C-9	6	6 15/16	17,000	3400
EBW	No. B2 - Blue - Inside frost	500	115 - 120	PS-25	Medium	C-9	6	6 15/16	10,500	4800
ECA	Inside frost	250	120	A-23	Medium	C-9	20	6	6,500	3200
ECT	Inside frost	500	120	PS-25	Medium	C-9	60	6 15/16	13,650	3200
ECV	Inside frost	1000	120	PS-40	Mogul	C-7A	60	9 3/4	26,500	3200

GE Lamp Code	Description	Watts	Volts	Bulb	Base	Filament	Rated Average Life (Hours)	Max. Overall Length (Inches)	Beam Angle†	Approx. Center-beam Candlepower	Approx. Color Temp. (K)
PHOTOFLOOD LAMPS											
Reflector. Table 19.											
BEP	Medium Beam - I.F.	300	115 - 120	R-30	Medium	C-9	4	5 13/16	30°	11,000	3400
DXB	Spot Beam - I.F. - (RSP-2)	500	115 - 120	R-40	Medium	CC-2V	6	6 5/8	15°	45,000	3300
DXC	Flood Beam - I.F. - (RFL-2)	500	115 - 120	R-40	Medium	C-9	6	6 5/8	90°	5,500	3300
EAL	Medium Beam - I.F.	500	120	R-40	Medium	CC-2V	15	6 5/8	60°	6,800	3200
EXS*	Multi-Mirror® Quartzline®	200	30	MR-16	2-pin / GX5.3	CC-6	50	1 3/4	45°	8,800	3300
EXV	Multi-Mirror® Quartzline®	100	12	MR-16	2-pin / GX5.3	CC-6	50	1 3/4	53°	3,100	3350
EXX	Multi-Mirror® Quartzline®	250	120	MR-16	Oval 2-pin / GY5.3	CC-8	25	1 3/4	57°	6,750	3300
EZK	Multi-Mirror® Quartzline®	150	120	MR-16	Oval 2-pin / GY5.3	CC-8	200	1 3/4	60°	3,600	3200

† Approx. beam spread to 1/2 center-beam intensity

GE Lamp Code	Description	Watts	Volts	Bulb	Base	Rated Average Life (Hours)	Operating Position	Max. Overall Length (Inches)	Approx. Initial Lumens	Approx. Color Temp. (K)
ENLARGER & PRINTER LAMPS										
Table 20.										
PH/111A	Enlarger - White	75	125	S-11	S.C. Bay.	25	BDTH	2 3/8	1120	2900
PH/140	Enlarger - White	75	120	S-14	Medium	50	Any	3 3/8	1150	2900
PH/211	Enlarger - White	75	115 - 125	A-21	Medium	100	Any	4 15/16	1000	3000
PH/212	Enlarger - White	150	115 - 125	A-21	Medium	100	Any	4 15/16	2300	3050
PH/213	Enlarger - White	250	115 - 125	A-21	Medium	3	Any	4 15/16	7000	3400
PH/1400	Enlarger - White	75	230	S-14	Medium	50	Any	3 3/8	1100	2900
BBA	No. 1 Photoflood - I.F.	250	115 - 120	A-21	Medium	3	Any	4 15/16	8500	3400
BEV	Printer	150	20	G-16 1/2	S.C. Pref.	50	BU	3	4000	3300
DDF	Multi-Mirror®	55	17	MR-16	2-pin	300	BDTH	1 3/4	—	3100
DLS/DLG/DHX	Internal Dichroic Reflector	150	22	T-14	4-Pin	15	BDTH	3 7/16	—	3250
EJL	Multi-Mirror®	200	24	MR-16	2-Pin	50	BDTH	1 3/4	—	3400
EJV	Reflector Quartzline®	150	21	MR-16	2-Pin	40	BDTH	1 3/4	—	3350
ELC	Multi-Mirror®	250	24	MR-16	2-Pin	50	BDTH	1 3/4	—	3400
ELH	Multi-Mirror®	300	120	MR-16	Oval 2-Pin	35	BDTH	1 3/4	—	3350
ENH	Multi-Mirror®	250	120	MR-16	Oval 2-Pin	175	BDTH	1 3/4	—	3250
ESD	Multi-Mirror®	150	120	MR-16	Oval 2-Pin	12	BDTH	1 3/4	—	3350
ESJ	Multi-Mirror®	85	82	MR-16	Oval 2-Pin	40	BDTH	1 3/4	—	3350
EVW	Multi-Mirror®	250	82	MR-16	Oval 2-Pin	50	(4)	1 3/4	—	3300
EYA	Multi-Mirror®	200	82	MR-16	Oval 2-Pin	50	BDTH	1 3/4	—	3300
EZF/EZJ ⁽¹⁾	Multi-Mirror®	225	68	MR-13	2-Pin	500	BDTH	1 3/4	—	(1)
FAL	Quartzline®	420	120	T-4	RSC	75	Any	2 5/8	11,000	3200
FFJ	Quartzline®	600	120	T-4	RSC	75	Any	2 5/8	17,000	3250

(1) Red-enhanced dichroic reflector. (4) Operate base-down to 22° base-up.



CAUTION NOTICE

INCANDESCENT PROJECTION, ENLARGER, AND PRINTER LAMPS

CAUTION - GENERAL ELECTRIC GLASS PROJECTION LAMPS WITH THREE-LETTER ANSI CODES OPERATE UNDER PRESSURE, ABOVE ROOM TEMPERATURE AND MAY UNEXPECTEDLY SHATTER. Protect people and surroundings from the possibility of injury or fire from hot, flying fragments with a suitable enclosure, shield, lens or screen. Do not operate projection equipment with the lamp compartment open. Observation of the following operating instructions will help avoid early lamp failure.

1. Use lamp only in equipment specifying this lamp type and which provides adequate ventilation to maintain lamp within safe operating temperatures. If in doubt, contact equipment manufacturer.
 2. Operate lamp only in the position indicated by the instructions on the lamp or lamp package, or as noted in the GE catalog description of the lamp.
 3. Do not bump or bounce equipment during operation.
 4. Protect lamp from moisture, scratches or abrasions.
 5. Replace lamp if it blisters or prematurely darkens.
 6. Replace lamp socket if deterioration of socket is noticed.
- To avoid electrical shock or burns, be sure power is off and lamp has fully cooled before replacing lamp.

SUBSTITUTE LAMP GUIDE

For the lamps listed below, there is no appropriate GE substitute lamp. Those that are footnoted "Discontinued by General Electric" (example: BAF*) are obsolete types - in most cases, no longer produced by any lamp manufacturer. The remainder of the lamps below are currently produced General Electric types with unique design/construction features tailored specifically to the requirements of the projection equipment for which they are originally designed. Consequently, we can offer substitute lamp for direct replacement.

All currently listed ANSI-coded GE Projection Lamps appear in the Substitute Guide - either in the table below (no substitute), or in the first column of the substitution tables beginning on page 8-18.

No General Electric Substitute Lamp is Available for the Following Lamps

BAF*	BHA*	BSS	CAY*	CNX*	CYL*	DDN	DLT*	DXX	EFR	EPT	EZS
BAJ*	BHB	BSW	CBA	CPB*	CYN*	DDP	DLY*	DYA	EGX	EPV	EZT
BAL*	BHD	BTD	CBX	CPF*	CYR*	DDS	DMB*	DYF	EHA	EPW*	FAF*
BAS*	BHG*	BTK*	CCB*	CPG*	CZC*	DEA*	DMG*	DYG	EJH	EPX	FAL
BBB	BHH	BTT*	CCK	CPR*	CZD*	DED	DMH*	DYH	EJA	EPZ	FBC*
BBJ*	BHK*	BVA*	CCR*	CPW*	CZG*	DEF	DMJ	DYJ	EJM	ERV	FBF*
BBX*	BHR*	BVB*	CDW*	CRC*	CZJ*	DEJ*	DML*	DYP	EJV	ESC*	FPG
BCA	BHW*	BVE	CDK*	CRL*	CZS*	DES*	DMS	DYR	EJY	ESD	FBK*
BCJ*	BJC*	BVK	CDR*	CRS*	DAC*	DET*	DNC*	DYS	EJZ*	ESJ	FBL*
BCS*	BJJ*	BVL	CER*	CRX*	DAE*	DEX*	DNE	DYT	EKB	ETJ	FBM*
BCW*	BJS*	BVR	CFA*	CSD*	DAG*	DFH*	DNF	DYY	EKC*	ETS*	FBZ*
BDD*	BJW*	BWC*	CFR*	CST*	DAN*	DFJ*	DNK*	DZA	EKL	ETT	FCB
BDK	BKC*	BWJ*	CFY*	CTB*	DAR*	DFN	DRL*	DZB	EKN	EVV	FCE*
BDW	BKG*	BWR*	CGD*	CTL	DAS*	DFR*	DSR*	DZE	EKP	EWF	FCH*
BEB*	BKR*	BWY*	CGE	CTM*	DBK*	DGA*	DSW	DZR*	EKX	EWM*	FCK
BEC*	BKV	BXB	CGJ*	CTR*	DBR*	DGE*	DTS	EAD*	EKZ	EWR	FCR
BEP	BLC	BXE	CGP	CTW*	DBT*	DGJ*	DTW*	EAH*	ELA	EXL	FDT
BES*	BLG*	BXJ	CHG*	CVJ*	DBX*	DGS*	DWB*	EAJ	ELD	EXM	FEA*
BEV*	BMA*	BXK*	CHS*	CVS	DCE*	DGX*	DWE*	EAK*	ELE	EXS	FEB*
BEY	BMJ*	BXT	CHW*	CWG*	DCF	DHB*	DWF*	EAL	ELJ	EXV	FFJ
BFA	BMK*	BXW*	CHY	CWR*	DCH*	DHH*	DWH*	EAP*	ELS	EYA	FFM
BFB*	BMS	BYD*	CJD*	CWY*	DCL*	DHJ*	DWK	EAW*	EMC	EYB	FGA*
BFC*	BNB*	BYJ*	CJT*	CXD*	DCN*	DHW*	DWL*	EBR	EMG*	EYH	FGB*
BFJ*	BNK*	BYM*	CJW*	CXG*	DCS*	DJD*	DWN*	EBW	EMH*	EZD	FGC*
BFR*	BNS*	BYR*	CKB*	CXH*	DCW	DJR*	DWW*	EBY	EML	EZE	FGD*
BFT*	BPG*	BYT*	CKS*	CYA*	DCY	DJT	DWZ*	ECA	EMM	EZF	FGR*
BFX*	BPR*	BZB*	CLD*	CYB*	DCF	DKF*	DXB	ECV	ENL	EZG	FHZ*
BFY*	BRD	BZD*	CMS*	CYC	DDJ	DKK*	DXC	EDK*	ENX	EZJ	FML
BGB*	BRK	BZG*	CNJ*	CYE*	DDK	DKY*	DXF*	EFM	ENZ	EZK	GEMINI-300 (EZG)
BGK*	BSX	CAD*	CNP*	CYF*	DDL	DLC*	DXL	EFN	EPG	EZL	MARC-300/35K (EZS)
BGW*	BSK	CAG*	CNS*	CYG*	DDM	DLD	DXT*	EPF	EPN	EZM	MARC-300/16 (EZM)
											MARC-350/16T (EZT)

* No longer manufactured; available only until stock is depleted.



GE SUBSTITUTE LAMP GUIDE

If a requested ANSI-Coded lamp is not found in the index to this section (pages 8-7 - 8-9), it may be listed as a GE Stage/Studio lamp. Check the ANSI Code Reference Table in the current GE Stage/Studio Lamp Catalog (SS-123P). If no current listing is found, a GE substitute lamp may nevertheless be available — as identified in the following Substitute Lamp Guide. Note: there are not GE substitute lamps for the ANSI codes listed on page 8-17.

This Substitute Lamp Guide (Showing GE lamps that may be substituted, if requested) is arranged under three main column headings:

1. **Lamp Requested...** the lamp asked for by the customer. Arranged alphabetically by code, lamps are further identified by their wattage and lamp end (clear or opaque). Many of the codes listed are further obsolete lamps; some are for other than photographic applications.
2. **This Lamp May Be Substituted...** a GE lamp that may be used instead of the requested lamp. These columns are identical to those of the requested lamp, for quick wattage and lamp-end comparison.
3. **Substitute Lamp Differs In These Respects, etc...** everything under this and the six sub-column headings pertains to the substitute lamp as compared to the requested lamp. For example: if the word "more" appears in the "light" column, the substitute lamp gives more light than the lamp requested.

Most of the recommended substitute lamps in this guide are directly interchangeable with the lamp requested. However, additional information may be needed in some instances:

Lower Wattage... When a lower wattage lamp is used as a substitute, the projected image will generally not be as bright as with the requested lamp.

Opaque End... Normally, a substitute lamp having an opaque end makes an excellent replacement for a clear end lamp (everything else being equal). However, opaque end lamps cannot be used where a highly specialized application requires light from the end of the lamp.

Proximity Reflector... The CZA type lamp may be substituted for the corresponding non-proximity type such as DAY/DAK...providing the socket does not position the lamp's reflector between the projector lens and the lamp filament.

Non-proximity... Ordinarily, non-proximity lamps should not be substituted for proximity reflector lamps since projectors designed for proximity lamps have no internal reflector.

Internal Dichroic Reflector... Lamps with internal dichroic reflectors may substitute for internal metal reflector lamps...for example: DEF for DCA, or DLS for DLG. Dichroic lamps of equal wattage and design life give the same amount of light with about 50% less heat at the film aperture.

Internal Metal Reflector... Internal metal reflector lamps should not be used as replacements for internal dichroic reflector lamps...for example: DCA for DEF, or DLG for DLS...because the cooling system of projectors designed for dichroic lamps is usually inadequate for the increased heat at the film aperture from metal-reflector lamps.

Code	Watts or Amperes	Lamp End	GE Code	Watts or Amperes	Lamp End	Light	Life	Heat	Lamp Dimensions	Other
LAMP REQUESTED			SUBSTITUTE LAMP			HOW SUBSTITUTE DIFFERS FROM REQUESTED LAMP				
BAH	300	frosted	BBA	250	frosted	less	less	less	same	—
BAK	.75A	clear	BRS	.75A	clear	same	less	same	same	—
BCK	500	clear	CZA	500	opaque	same	less	same	longer	Glass lamp
BDJ	200	clear	FEV	200	clear	more	more	same	smaller	Quartzline® lamp
BEH	150	opaque	CAR	150	opaque	same	same	same	same	Proximity reflector may not work in some projectors
BFD	750	clear	BFL	750	opaque	less	same	less	same	Monoplane filament
BFH	750	clear	BTP	750	clear	more	more	more	smaller	Quartzline® lamp
BFK	750	opaque	BFL	750	opaque	same	same	same	same	Special bulb for bowling score projectors
BFL	750	opaque	DGH	750	opaque	more	more	same	bulb 1" narrower	—
BHC	600	clear	DGH	750	opaque	more	more	same	bulb 1" narrower	—
BHF	100	opaque	DYS	600	clear	same	same	same	shorter lamp	Better performance
BKF	45	clear	BHD	100	clear	same	same	same	same	—
BLX	50	clear	BLC	30	clear	less	less	less	same	—
BMD	100	clear	BLC	30	clear	less	same	less	same	—
BMG	100	clear	BMY	100	clear	less	more	more	same	Larger filament
BNF	75	clear	BNF	75	clear	less	same	less	same	—
BNF	75	clear	BLX	50	clear	less	more	less	same	—

Projection Lamps



Code	Watts or Amperes	Lamp End	GE Code	Watts or Amperes	Lamp End	Light	Life	Heat	Lamp Dimensions	Other
LAMP REQUESTED			SUBSTITUTE LAMP			HOW SUBSTITUTE DIFFERS FROM REQUESTED LAMP				
BRH	1000	clear	DXW	1000	clear	less	more	same	same	3200°K
			DXN	1000	clear	more	less	same	same	3400°K
BTC	1000	clear	DGS	1000	clear	more	less	more	same	—
BTS	800	clear	DVY	650	clear	less	more	less	same	G-6 bulb
BWB	2000	clear	BWA	2000	clear	less	more	same	same	3200°K
BXE	7.5A	clear	7.5A/T8/92SC(10V)	7.5A	clear	same	same	same	same	—
BXM	4A	clear	4A/T8SCP(9V)	4A	clear	same	same	same	same	—
CAC	50	clear	CAX	50	clear	less	same	same	same	Larger filament
CAE	100	opaque	CDD	100	clear	same	same	same	same	—
CAJ	50	opaque	CAX	50	clear	same	same	same	same	Larger filament
CAR	150	opaque	BEH	150	opaque	same	same	same	same	Projector must have internal reflector
			DFE	150	opaque	less	more	less	same	—
CAS	50	clear	BZW	50	clear	less	same	less	same	—
CAW	50	opaque	CAX	50	clear	same	same	same	same	—
CAX	50	clear	BLX	50	clear	less	same	same	bulb 3/8" wider	—
CBF	500	opaque	DEK	500	opaque	less	more	less	slightly longer & wider	Burn horizontal only Not tungsten-halogen
CBS	75	clear	CBX	75	opaque	same	same	same	same	—
CCM	200	opaque	CGP	150	opaque	less	same	less	same	—
CDD	100	clear	CEM	100	opaque	less	more	same	same	—
CDJ	100	clear	CEB	100	clear	same	same	same	same	Larger filament
CDK	100	opaque	CBX	75	opaque	less	same	less	same	Different filament
CEA	100	opaque	CEB	100	clear	same	same	same	same	—
CEB	100	clear	CBX	75	opaque	less	same	less	same	—
CEL	110	opaque	CBX	75	opaque	less	less	less	same	—
CEM	120	opaque	CDD	100	opaque	more	less	less	same	—
CFK	150	clear	CGP	150	opaque	same	same	same	same	—
CLG	300	clear	CLS	300	opaque	same	same	same	same	—
CLL	500	opaque	CLS	300	opaque	less	same	less	same	Monoplane filament
CLM	300	clear	CLS	300	opaque	less	same	less	same	Monoplane filament
CMV	300	opaque	CLS	300	opaque	less	same	same	same	—
CTT	1000	opaque	CZA	500	opaque	less	same	less	—	Lamp 5/8" shorter, 1/4" narrower
(for CTS use CTT)										
CVX	200	opaque	CVS	200	clear	same	same	same	same	—
CWA	750	opaque	CZA	500	opaque	less	same	less	—	Lamp 5/8" shorter, 1/4" narrower
CWD	300	opaque	CAL	300	opaque	same	same	same	same	Proximity reflector may not work in some projectors
CXF	200	opaque	CTL	150	opaque	less	same	less	same	—
CXF	200	clear	CTL	150	opaque	less	same	less	same	Different filament
CXP	300	opaque	CAL	300	opaque	less	same	same	same	Proximity reflector
CZA	500	opaque	CAL	300	opaque	less	same	less	same	—
CZB	500	opaque	CZA	500	opaque	less	more	same	same	—
CZF	500	opaque	CZX	500	opaque	same	same	same	same	—
DAB	500	opaque	CZX	500	opaque	less	more	less	same	—
DAH	500	opaque	DEK	500	opaque	same	less	same	same	—
DAK	500	opaque	DAT	400	opaque	less	same	less	same	—
			DAY	500	opaque	same	more	same	same	Heat resistant bulb
DAN	200	frosted	BEP	300	frosted	more	same	more	1 1/4" wider	—
DAY	500	opaque	DAT	400	opaque	less	less	less	same	—
DBR	300	clear	CTL	150	opaque	less	same	less	bulb 1/4" narrower	—
DCA	150	opaque	DEF	150	opaque	same	same	less	same	Dichroic reflector
DCC	500	clear	CZX	500	opaque	same	same	same	same	—
DDB	750	opaque	CZX	500	opaque	less	same	less	bulb 1/4" narrower	—
DDW	750	opaque	DDB	750	opaque	less	same	same	same	—
			CZX	500	opaque	less	more	less	bulb 1/4" narrower	—
DDY	750	opaque	DGH	750	opaque	less	more	less	same	—

Projection Lamps



Code	Watts or Amperes	Lamp End	GE Code	Watts or Amperes	Lamp End	Light	Life	Heat	Lamp Dimensions	Other
LAMP REQUESTED			SUBSTITUTE LAMP			HOW SUBSTITUTE DIFFERS FROM REQUESTED LAMP				
DEK	500	opaque	CBA	500	opaque end	same	more	same	same	Quartzline®
DEL	500	opaque	DEK	500	opaque	less	more	same	same	25 hour life-33% less light
DEP	750	opaque	DAY	500	opaque	less	same	less	smaller	Heat resistant bulb
		opaque	DEK	500	opaque	more	less	more	shorter	—
DFC	150	clear	DFN	150	clear	same	same	same	—	—
DFE	80	clear	DGB	80	clear	same	same	same	longer	—
DFP	150	opaque	CAR	150	opaque	more	less	same	same	—
DFN	150	clear	DCH	150	clear	less	same	same	longer	—
DFW	150	clear	DCH	150	clear	same	same	same	longer	—
DFZ	80	clear	DEK	500	opaque	same	same	same	shorter	—
DGL	1000	clear	DLD	80	clear	same	more	same	smaller	—
DGR	750	opaque	DGS	1000	clear	more	less	same	same	10 hour
DHN	500	opaque	DAY	500	opaque	less	more	less	smaller	Heat resistant bulb
DHR	1200	opaque	DEK	500	opaque	same	same	same	shorter	—
DHS	1200	clear	DHT	1200	opaque	same	same	same	same	—
DHX	150	clear	DGS	1000	clear	less	more	less	same	—
DJA	150	clear	DLS	150	clear	same	same	same	same	Different shaped bulb
DJB	200	clear	DCH	150	clear	same	same	same	same	—
DKR	150	clear	DCH	150	clear	less	same	less	same	—
DLE	80	clear	DLS	150	clear	same	same	same	same	Longer focal length
DLG	150	clear	DLD	80	clear	same	same	same	shorter	—
DLH	250	opaque	DLS	150	clear	same	same	less	same	Dichroic reflector
DLN	750	opaque	DJL	150	clear	less	same	less	same	—
DMD	80	clear	DEK	500	opaque	less	same	less	shorter bulb	—
DMX*	500	clear	DGB	80	clear	same	same	same	—	Different shape bulb
DMY	5000	clear	BTM	500	clear	more	more	same	smaller	Tungsten-halogen lamp
DMZ	5000	clear	DPY	5000	clear	more	more	same	1" longer	Monoplane filament
DNT/FMD	750	clear	DPY	5000	clear	less	more	same	1" longer	Monoplane filament
DNV/FME	1000	clear	EGF	750	clear	more	same	same	smaller	CC-8 filament
DPK	5000	clear	EGJ	1000	clear	same	more	same	smaller	CC-8 filament
DPZ	5000	clear	DPY	5000	clear	more	more	same	smaller	Quartzline® lamp
DRB	1000	clear	DRB	1000	clear	less	more	less	same	3200°K
DRC	1000	clear	DRC	1000	clear	more	less	more	same	50 hour lamp
DRW	1000	clear	DPT	1000	clear	more	same	same	same	25 hour lamp
DSD	1000	frosted	DKZ	1000	frosted	more	more	same	larger	PS-52 bulb
DSN	750	clear	EGR	750	clear	more	same	same	smaller	Quartzline®-3200°K
DTZ	10M	clear	DTY	10M	clear	less	more	same	same	3200°K
DVB	1000	clear	CYV	1000	clear	more	more	same	smaller	Quartzline®-3200°K
DVE	2000	clear	CYX	2000	clear	same	more	same	smaller	Quartzline® lamp
DVJ	2000	clear	CYX	2000	clear	same	more	same	smaller	Quartzline® lamp
DVN	25	clear	25S6	25	clear	same	same	same	same	—
DVS	500	clear	Q500T3/CL(130V)	50	clear	more	less	same	same	130 volt lamp
DVV	1500	clear	FER	1000	clear	less	more	less	same	—
DVY	650	clear	FEY	2000	clear	more	same	more	same	1/3 more heat
DWA	650	—	DYH	600	clear	less	more	less	same	3200°K
DWC	150	frosted	FGS	250	—	less	less	less	same	Replacement lamp only
DWT	1000	clear	150R/FL	150	frosted	same	same	same	same	—
DWW	460	clear	Q1000T6/CL	1000	clear	same	same	same	same	—
DWY	650	clear	FAL	420	clear	less	more	less	same	—
DXD	500	frosted	FAD	650	clear	less	more	same	same	3200°K lamp
DXE	500	frosted	DXB	500	frosted	more	less	more	same	118V lamp
DXH	375	frosted	DXC	500	frosted	more	less	more	same	118V lamp
DXN	1000	clear	EAL	500	frosted	more	same	more	same	1/3 more heat
DXS	1000	frosted	BRH	1000	clear	less	more	same	same	3350°K lamp
DXV	800	clear	DXR	1000	frosted	more	less	less	same	—
			DXX(230V)	800	clear	less	more	same	same	3200°K

Projection Lamps



Code	Watts or Amperes	Lamp End	GE Code	Watts or Amperes	Lamp End	Light	Life	Heat	Lamp Dimensions	Other
LAMP REQUESTED			SUBSTITUTE LAMP			HOW SUBSTITUTE DIFFERS FROM REQUESTED LAMP				
DXY	650	—	DWE	650	—	less	more	same	same	Quartzline® lamp
DYV	600	clear	DYS	600	clear	same	same	same	same	—
DZM	250	clear	DZE	150	clear	less	more	less	same	—
EBV	500	frosted	ECT	500	frosted	less	more	same	same	3200°K
ECC	1000	clear	BVV	1000	clear	same	more	same	smaller	Quartzline® lamp
ECG	2000	clear	CYX	2000	clear	same	more	same	smaller	Quartzline® lamp
ECJ	2000	clear	CYX	2000	clear	same	more	same	smaller	Quartzline® lamp
ECK	2000	clear	CYX	2000	clear	less	more	same	smaller	Quartzline®-3200°K
ECL	2000	clear	CYX	2000	clear	less	more	same	smaller	Quartzline®-3200°K
ECM	5000	clear	DPY	5000	clear	less	more	same	smaller	Quartzline®-3200°K
ECP	10M	clear	DTY	10M	clear	less	more	same	smaller	Quartzline®-3200°K
ECT	500	frosted	EBV	500	frosted	more	less	same	same	3400°K
ECX	1000	clear	DKZ	1000	frosted	same	more	same	same	Quartzline® lamp
ECY	1500	frosted	DKX	1500	frosted	same	more	same	same	Quartzline® lamp
EDF	1000	clear	DPT	1000	clear	same	more	same	same	—
EDL	2000	clear	CYX	2000	clear	less	more	same	smaller	Quartzline®-3200°K
EDM	2000	clear	CYX	2000	clear	less	more	same	smaller	Quartzline®-3200°K
EDN	5000	clear	DPY	5000	clear	less	more	same	smaller	Quartzline®-3200°K
EDR	100	clear	100T8 1/2/9	100	clear	same	same	same	same	—
EDZ	500	frosted	EBV	500	frosted	more	less	more	same	118V lamp
EEM	1000	frosted	DKZ	1000	frosted	same	more	same	same	Quartzline® lamp
EER	2000	clear	CYX	2000	clear	same	less	same	smaller	—
EFJ	1000	frosted	FCV	1000	frosted	more	less	same	same	—
EGD	500	clear	EGC	500	clear	more	same	same	same	—
EGL	1000	clear	EGJ	1000	clear	more	same	same	same	—
EGS	750	clear	EGR	750	clear	less	more	same	same	3200°K
EGV	1000	clear	EGT	1000	clear	less	more	same	same	3200°K
EHB	500	clear	EHC	500	clear	more	less	same	same	—
EHK	1000	clear	FEL	1000	clear	more	less	same	same	—
EHM	300	clear	Q300T2 1/2/CL	300	clear	same	same	same	same	—
EHP	400	clear	Q300T4/CL	300	clear	same	same	same	same	—
EHR	400	clear	Q400T4/CL	400	clear	same	same	same	same	—
EHS	1000	clear	FER	1000	clear	more	same	same	same	—
EHT	250	clear	Q250CL/MC	250	clear	same	same	same	same	—
EHZ	300	frosted	Q300T2 1/2	300	frosted	same	same	same	same	—
EJB	800	clear	EME	800	clear	less	more	less	same	240V lamp
EJC	800	frosted	EMF	800	clear	less	more	less	same	240V lamp
EJE	1000	frosted	EJD	1000	clear	same	same	same	same	—
EJL	200	clear	EJA	150	clear	less	less	less	same	—
EJN	150	clear	ELD	150	clear	same	same	same	same	Multi-Mirror® reflector- better coverage
EJS	150	clear	EJM	150	clear	less	more	same	same	—
EJV	150	clear	EKE	150	clear	same	more	less	same	200 hour lamp
EKD*	650	clear	DYS	600	clear	less	more	less	same	—
EKE	150	clear	EJV	150	clear	same	less	more	same	25 hour lamp
EKG	80	clear	ENW	80	clear	same	more	less	same	200 hour lamp
EKH	800	clear	EME	800	clear	less	more	less	same	240V lamp
EKP	80	clear	EPK	80	clear	more	less	more	same	—
EKS	250	clear	EMM	250	clear	same	more	same	same	—
EKV	1100	clear	ELJ	1050	clear	less	more	less	same	3200°K
ELB	80	clear	ENZ	50	clear	less	more	less	same	—
ELC	250	clear	EJL	200	clear	less	same	less	same	—
ELH	300	clear	ENG	300	clear	more	less	more	same	—
			ENH	250	clear	less	more	less	same	—
ELR	65	clear	ELS	50	clear	less	more	less	same	—
ELV	150	clear	DNF	150	clear	more	less	same	same	25 hour lamp
EMB	150	clear	EJV	150	clear	less	more	less	same	—
EMJ	5000	clear	DPY	5000	clear	same	more	same	smaller	Quartzline® reflector
ENA	80	clear	EKP	80	clear	same	more	same	same	Dichroic reflector

Projection Lamps



Code	Watts or Amperes	Lamp End	GE Code	Watts or Amperes	Lamp End	Light	Life	Heat	Lamp Dimensions	Other
LAMP REQUESTED			SUBSTITUTE LAMP			HOW SUBSTITUTE DIFFERS FROM REQUESTED LAMP				
ENB	150	clear	EJV	150	clear	more	less	same	same	—
			EKE	150	clear	less	more	same	same	—
ENC	80	clear	ENW	80	clear	same	more	less	same	—
ENG	300	clear	ELH	300	clear	less	more	less	same	—
			ENH	300	clear	less	more	less	same	—
ENH	250	clear	ELH	300	clear	more	less	more	same	—
			ENG	300	clear	more	less	more	same	—
ENN	80	clear	ELB	80	clear	more	less	more	same	—
ENX	360	clear	EVW	250	clear	less	less	less	same	—
EPK	80	clear	EKP	80	clear	less	more	less	same	—
ESH	85	clear	EZW	85	clear	less	more	less	same	—
ESL	150	clear	Q150CL/MC2V	150	clear	same	same	same	same	—
ESM	250	frosted	Q250MC	250	frosted	same	same	same	same	—
ESN	100	clear	Q100CL/MC	100	clear	same	same	same	same	—
ESP	150	clear	Q150CL/DC/2V	150	clear	same	same	same	same	—
ESR	100	clear	Q100CL/DC	100	clear	same	same	same	same	—
ESS	250	clear	250CL/DC	25	clear	same	same	same	same	—
EST	1000	clear	DXN	1000	clear	same	more	same	same	—
ESX*	25	clear	FHX	250	clear	more	less	same	same	250 hour lamp
ETT	1000	clear	DXN	1000	clear	more	less	same	same	—
EVA	100	clear	FCR	100	clear	more	less	less	same	50 hour lamp
EWG	300	clear	EYK	300	clear	less	more	less	same	—
EXR	300	clear	EXW	300	clear	more	less	more	same	—
			FHS	300	clear	less	more	less	same	—
EXW	300	clear	EXR	300	clear	less	more	less	same	—
			FHS	300	clear	less	more	less	same	—
EXX	250	clear	EZK	150	clear	less	more	less	same	3200°K
EXY	250	clear	EZE	150	clear	less	less	less	same	—
EZB	250	clear	FGS	250	clear	more	less	same	same	3400°K
EZW	85	clear	ESH	85	clear	more	less	more	same	—
FAP	650	—	FAY	650	—	more	more	same	same	Quartzline® lamp
FAZ	650	—	DXK	650	—	more	more	same	same	Narrower beam
FBD	500	clear	FBG	500	clear	same	same	same	shorter	More rugged construction
FCL	500	clear	Q500T3/CL	500	clear	same	same	same	same	—
FCS	150	clear	FDV	150	clear	less	more	less	same	—
FCZ	500	frosted	Q500T3	500	frosted	same	same	same	same	—
FDS	150	clear	DZE	150	clear	more	less	more	same	—
FDV	150	clear	FCS	150	clear	more	less	more	same	—
FGJ	650	—	FAY	650	—	more	more	same	same	Narrower beam
FGP	1000	—	FGN	1000	—	more	same	same	same	Narrower beam
FGS	250	—	EZB	250	—	less	more	same	same	2950°K
FGV	1000	frosted	FFT	1000	clear	same	same	same	same	—
FGW	150	clear	DZE	150	clear	more	less	same	same	—
FHS	300	clear	EXR	300	clear	more	less	more	same	—
			EXW	300	clear	more	less	more	same	—
FHX	25	clear	ESX	25	clear	less	more	same	same	500 hour lamp
FKA	650	clear	BTL	500	clear	less	less	less	same	—
			BTN	750	clear	more	less	more	same	15% more heat
FKC	1000	clear	BTR	1000	clear	more	less	same	smaller	—
FKL	650	clear	BTL	500	clear	less	less	less	same	—
			BTP	750	clear	more	more	more	same	15% more heat
FKT	250	clear	EYH	250	clear	more	same	same	same	G-6 bulb
FKV	650	clear	EHC	500	clear	less	same	less	same	—
			EHF	750	clear	more	same	more	same	15% more heat
FMD	750	clear	EGF	750	clear	more	same	same	smaller	CC-8 filament
FME	1000	clear	EGJ	1000	clear	same	more	same	smaller	CC-8 filament
FXL	410	clear	ENX	360	clear	less	more	less	same	—
MARC®			GEMINI™							
300/16A	300	clear	300(EZM)	300	clear	same	more	same	same	—

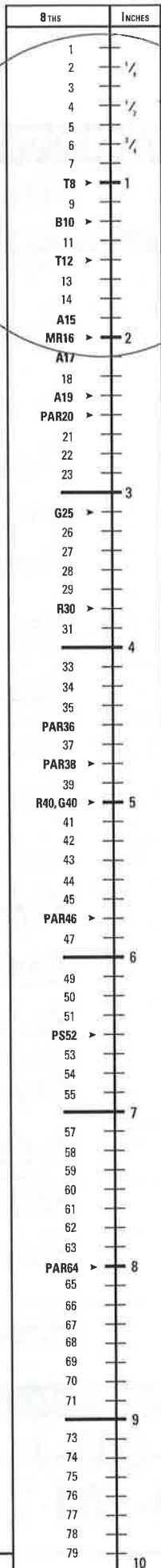

LAMP SIZING GUIDE

Lamp Size or diameter (maximum) is expressed in eighths of an inch ($\frac{1}{8}$ "), (3.2mm).

For example: an A17 bulb is 17-eighths of an inch or $2 \frac{1}{8}$ " (54mm) in diameter at its maximum dimension.

GE'S GLOBAL LEADERSHIP

GE lamps are favored throughout the world, lighting up such diverse locations as the Palace of the Lost City in South Africa, the Sydney Opera House, and the historic town of Cuzco, Peru. GE Lighting operates five primary business centers worldwide to serve our global customers. These centers (shown below) provide leadership in product technology, sales growth and new product introductions.

Other GE lighting business centers produce many products not available in the USA. These businesses provide individual catalogs listing products available in their markets. These include operations in Mexico, South America, Europe, Asia. Please see page 2, for a complete listing of international sales offices.

GLOBAL BUSINESS CENTERS

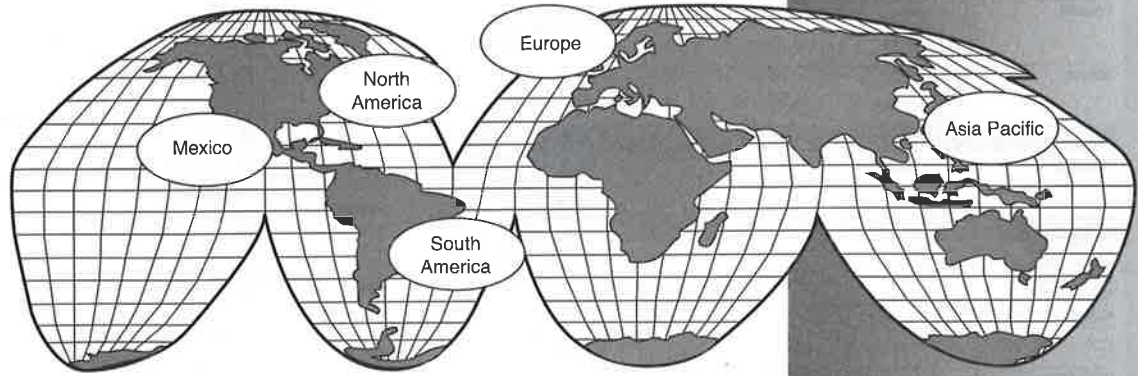

APPENDIX LISTINGS:

Lamp Sizing Guide	1
GE's Global Leadership	1
GE International Sales Offices	2
GE Domestic Sales Offices	3
Glossary	4
Selecting the Best Color Lamp	8
Color Rendering & Chromaticity Data	8



INFORMATION ON GE LAMPS – WORLDWIDE – IS AVAILABLE AT THE FOLLOWING LOCATIONS

UNITED STATES	GE Lighting Export Sales Nela Park – 1975 Noble Road Cleveland, Ohio 44112-8300 U.S.A.	Phone: (216) 266-6889 Fax: (216) 266-2780	JAPAN	Hitachi GE Lighting Ltd, Suda-cho Sashida Bldg. 2-5-2 Kanda-suda Cho Chiyoda-ku, Tokyo 101-0041 JAPAN	Phone: (81-3) 5296-2911 Fax: (81-3) 5296-2920
ARGENTINA	GE Iluminacion S.A. Av. San Martin s/n esquina 25 de Mayo 1618-El Talar Tigre. Pcia de Buenos Aires ARGENTINA	Phone: (5411) 4736-6666 Fax: (5411) 4736-6616	KOREA	GE Samsung Lighting Co. Ltd, Samsuk Bldg. 3rd Floor 891-43, Daechi-Dong Kangnam-Ku Seoul 135-280 KOREA	Phone: (82-2) 569-4181 Fax: (82-2) 563-9833
AUSTRALIA NEW ZEALAND	GE Lighting Australia 125-127 Long Street Smithfield, NSW 2164 AUSTRALIA	Phone: (61-2) 9729-0011 Fax: (61-2) 9809-3242	MALAYSIA	GE Lighting (Malaysia) 25th Fl. UBN Tower No. 10 Jalan P. Ramlee Kuala Lumpur 50250 MALAYSIA	Phone: (60-3) 236-4279 Fax: (60-3) 202-1129
AUSTRIA	GE Lighting AG Hofh�r-Schranzt-Gasse 4 Postfach 17 1211 Vienna AUSTRIA	Phone: (43-1) 277724 Fax: (43-1) 27772-391	MEXICO	GE Lighting Mexico, S.A. de C.V. Av. Chirubusco 3900 Norte Apartado Postal 216 64510 Monterrey, N.L. MEXICO	Phone: (52-8) 318-5600 Fax: (52-8) 318-5690
BELGIUM	GE Lighting 5 Avenue Ariane/4th Floor 1200 Brussels BELGIUM	Phone: (32-2) 776-0675 Fax: (32-2) 776-0687	NETHERLANDS	GE Lighting Burgemeester Goudsmitlaan 5 3956 GS Leersum NETHERLANDS	Phone: (31) 34 34 52149 Fax: (31) 34 34 51464
BRAZIL PARAGUAY BOLIVIA	General Electric do Brasil, S/A Parque Industrial Thomas Alva Edison Rua Miguel Angelo, 37 Maria da Graça Rio de Janeiro 20783-900 BRAZIL	Phone: (55-21) 582-6107 (55-21) 261-1747 Fax: (55-21) 582-6509	NORWAY	GE Lighting AS P.O. Box 184 N-1483 Skytta NORWAY	Phone: (47) 67060480 Fax: (47) 67060220
CARIBBEAN CENTRAL AMERICA	GE Lighting 790 N.W. 107 Avenue Suite 204 Miami, Florida 33172 CARIBBEAN	Phone: (305) 551-5174 Fax: (305) 551-5116	PERU	GE Lighting Peru Av. Garcilaso de la VEGA 1420 Esquina con Av. Espana Lima PERU	Phone: (511) 433-8862 Fax: (511) 332-0482
CHILE ECUADOR	General Electric de Chile S/A Casilla 2103 Av. Vicuna Mackenna 2385 Santiago CHILE	Phone: (56-2) 555-3031 Fax: (56-2) 556-7329	PHILIPPINES GUAM	Philippine Electrical Manufacturing Co., 1873 P. Domingo Street City, Metro Manila P.O. Box 2087MCC THE PHILIPPINES	Phone: (83-2) 895-7051/207 Makati Fax: (83-2) 890-8186
CHINA	GE Jiabao Lighting Company 4727 Zhen Nan Road Nanxiang Town Jiading District Shanghai PRC 201802 CHINA	Phone: (86-21) 5-912-7777 Fax: (86-21) 5-912-6287	RUSSIA	GE Lighting Kosmodamianskaya Naberezhnaya 52 Bldg. 1 Moscow 113054 RUSSIA	Phone: (7502) 935-7276 Fax: (7502) 935-7279
COLOMBIA	General Electric Iluminacion Colombia GEICO LTDA Carrera 99 #46A-46 Santafe de Bogota, Colombia COLOMBIA	Phone: (57-1) 298-1764 Fax: (57-1) 415-3888	SINGAPORE	GE Lighting – Asia Pacific Oprs. 240 Tanjong Pagar Rd. #06-00 GE Tower Singapore 088540 SINGAPORE	Phone: (65) 326-3215 Fax: (65) 326-3227
DENMARK	GE Lighting A/S Sdr. Ringvej 45 DK-2605 Brondby DENMARK	Phone: (45) 43-237400 Fax: (45) 43-237475	SOUTH AFRICA	GE Lighting South Africa (Pty) Ltd. 5 Bridget Road, Benrose 2094 P.O. Box 27067, Benrose 2011 SOUTH AFRICA	Phone: (27-11) 618-3870 Fax: (27-11) 614-4530
EGYPT ERITREA ETHIOPIA	GE International Operations Co., 54, Lebanon St. Mohandessin, Giza, Egypt EGYPT	Phone: (20-2) 301-8060 Fax: (20-2) 303-1082	SPAIN PORTUGAL	GE Lighting S.A. C/Muntaner No. 479 2-1a SPAIN	Phone: (34-3) 418 21 00 Fax: (34-3) 417 24 177
FINLAND	GE Lighting Oy Vornissakatu 6, 7 KRS FIN-01530 Vantaa FINLAND	Phone: (358) 9-836-2100 Fax: (358) 9-836-21020	SWEDEN	GE Lighting AB Box 6789 SE-Eriksgratan 117 S-113 85 Stockholm SWEDEN	Phone: (46) 8-457-9600 Fax: (46) 8-457-9645
FRANCE	GE Lighting SARL Paris Nord II 13 Rue de la Perdrix BP 50073 95072 Roissy Charles de Gaulle CEDEX PARIS, FRANCE	Phone: (33-1) 4863-6800 Fax: (33-1) 4863-6808	SWITZERLAND	GE Lighting AG Thurgauerstr. CH-8050 Zurich SWITZERLAND	Phone: (41-1) 307-1200 Fax: (41-1) 307-1201
GERMANY	GE Lighting GmbH Praunheimer Landstrabe 50 60488 Frankfurt Am Main GERMANY	Phone: (49) 6997-607240 Fax: (49) 6997-679024	TAIWAN	GE Lighting Taiwan 13 Floor, No. 168 Tun-Hwa N. Road Taipei, Taiwan REPUBLIC OF CHINA	Phone: (886) 2-2714-7000 Fax: (886) 2-2547-4568
GREECE/CYPRUS NORTH AFRICA SOUTH AFRICA WEST AFRICA MIDDLE EAST	GE International 6, Rue du Simplon CH-1207 Geneva SWITZERLAND	Phone: (41-22) 735 9260 Fax: (41-22) 786 5525	THAILAND	GE Lighting (Thailand) Ltd. 191 Silom Complex Bldg., 22nd Floor Silom Rd., Silom, Bangrak Bangkok 10500 THAILAND	Phone: (662) 266-2621 Fax: (662) 266-2626
HUNGARY	GE Lighting Tungsram IV, Vaci ut 77 H-1340 Budapest HUNGARY	Phone: (36-1) 369 2800 Fax: (36-1) 369-1779	TURKEY	GENERAL ELEKTRIK T.A.S. Davutpaşa Caddesi No. 4 Topkapı Istanbul TURKEY	Phone: (90) 212-544-4400 Fax: (90) 212-576-0979
HONG KONG	General Electric International Operations Co., Inc. 11/F, The Lee Gardens 33 Hysan Ave. Causeway Bay HONG KONG	Phone: (852) 2100-6900 Fax: (852) 2376-0013	UKRAINE	GE Kiev 42/44 Shefkovichnaya Str. 250004 Kiev UKRAINE	Phone: (380-44) 459-0483 Fax: (380-44) 459-0482
INDIA	GE Lighting Ltd. HR Complex, 310/6 Industrial Main Road Koramangala 5th Block Bangalore 560 095 INDIA	Phone: (91-80) 552-2025 Fax: (91-80) 552-2021	UNITED KINGDOM	GE Lighting Europe Conquest House 42-44 Wood St. Kingston-upon-Thames Surrey KT1 1UZ ENGLAND	Phone: (44-181) 626-8500 Fax: (44-181) 626-8501
INDONESIA	PT GE Lighting Indonesia Menara Batavia, 6th Floor Jalan K.H. Mas Mansyur Kav 126 Jakarta 10220 INDONESIA	Phone: (62-21) 574-5240 Fax: (62-21) 574-5241	URUGUAY	Indunor S.A. Br. Espana 2063 Casilla de Correo 360 11200 Monevideo URUGUAY	Phone: (598-2) 400140 Fax: (598-2) 498659
IRELAND	GE Lighting Limited 280 Holly Road Western Industrial Estate Naas Road Dublin 12 IRELAND	Phone: (353-1) 456-5591 Fax: (353-1) 450-4142	VENEZUELA	GE Iluminacion de Venezuela S.A. (GEISA) Avenida General Motors Zona Industrial Sur Apartado 529, Valencia 2003 Estado Carabobo VENEZUELA	Phone: (5841) 302011 Fax: (5841) 382621
ITALY	GE Lighting SPA Via Astichello No. 2 P.O. Box No. 604 36100 Vicenza ITALY	Phone: (39-0) 494-946-000 Fax: (39-0) 444-945-863			



GE LIGHTING DOMESTIC SALES OFFICES AND CUSTOMER SERVICE CENTERS

GE LIGHTING HEADQUARTERS

CLEVELAND, OH Nela Park, Cleveland, OH 44112 (216) 266-2121

SALES OFFICES

To Obtain Sales Information

City	Address	Zip No.	Area Code	Phone No.
ATLANTA, GA	2001 Westside Parkway, Suite 190, Alpharetta, GA	30004	(770)	753-3821
BALTIMORE, MD	7272 Park Circle Drive, 3rd Floor Hanover, MD	21076	(410)	737-7022
BIRMINGHAM, AL	300 River Hills Business Park P.O. Box 637 (35201)	35242	(205)	991-4111
BOSTON, MA	980 Washington St., Suite 219 North, Dedham, MA	02026	(781)	320-4200
CHARLOTTE, NC	4601 Park Road, Suite #100	28209	(704)	561-7371
CHICAGO, IL	2021 Spring Rd., Suite 550, Oak Brook, IL	60523	(630)	573-3500
CINCINNATI, OH	Northmark Business Center I 10101 Alliance Road, Suite 305	45242	(513)	243-8903
CLEVELAND, OH	1975 Noble Rd., Nela Park, E. Cleveland	44112	(216)	266-8359
DALLAS, TX	2080 McDaniel, Suite #200, Carrollton, TX P.O. Box 115035	75006 75011-5035	(972)	888-0548
DETROIT, MI	2300 Meijer Drive, Troy, MI P.O. Box 7031	48084 48007-7031	(248)	280-4853
GRAND RAPIDS, MI	5960 Tahoe Drive, S.E.	49548	(616)	956-3338
HOUSTON, TX	1240 Blalock Road, Suite 130	77055	(713)	932-6472
CARMEL, IN	12272 Hancock St.	46032	(317)	574-8295
KANSAS CITY, MO	8325 Lenexa Dr., Ste. 101, Lenexa, KS	66214	(913)	577-1048
LONG ISLAND, NY	1983 Marcus Ave., Suite 109 Lake Success, NY	11042	(516)	775-9200
LOS ANGELES, CA	16257 Laguna Canyon Rd., Suite 100 Irvine, CA	92618	(714)	450-4705
MILWAUKEE, WI	11950 W. Lake Park Dr., Suite 290	53224	(414)	359-1200
MINNEAPOLIS, MN	2905 Northwest Blvd., Suite 80, Plymouth, MN	55441	(612)	553-2100
NEW ORLEANS, LA	201 Evans Road - Suite 200, Harahan, LA	70123	(504)	731-5626
NEW YORK / NEW JERSEY	3000 Hadley Rd., 2nd Floor, South Plainfield, NJ GE Lighting Commercial & Industrial / Consumer / OEM	07080	(908)	822-1722 822-1734
NEW YORK, NY	1251 Avenue of the Americas, 7th Floor	10020	(212)	575-6616
PHILADELPHIA, PA	640 Freedom Business Center - 2nd Floor King of Prussia, PA	19406	(610)	992-6622
PITTSBURGH, PA	1370 Washington Pike, Bridgeville, PA	15017	(412)	221-6320
PORTLAND, OR	One Embassy Center 9020 SW Washington Square Rd., Suite #550 Tigard, OR	97223	(503)	526-7150
SACRAMENTO, CA	1018 22nd St. - 2nd Floor	95816	(916)	442-4062
SAN FRANCISCO, CA	1800 Sutter St., Suite 590, Concord, CA	94520	(510)	603-2400
SEATTLE, WA	1605 N.W. Sammamish Rd., Suite 300 Issaquah, WA	98027	(425)	557-3055
ST. LOUIS, MO	12101 Woodcrest, Executive Dr. - 2nd Floor St. Louis, MO	63141	(314)	579-7201
SYRACUSE, NY	1725 Meeker Hill Rd., Lafayette, NY	13084	(315)	677-7744
TAMPA, FL	8020 Woodland Center Blvd., Suite 100	33614	(813)	243-3010
WASHINGTON, DC	7125 Thomas Edison Dr., Suite 200 Columbia, MD	21046	(301)	621-8234*
CANADA	2300 Meadowvale Blvd., Mississauga, Ontario L5N 5P9 Commercial & Industrial Consumer	(905) 858-6592 (905) 858-5403		

In addition to the Sales Offices in the cities listed above, GE Lamp Sales Representatives are resident in other cities. Consult your telephone directory under GE Lighting.

FOR LAMP OR BALLAST TECHNICAL SUPPORT CALL

1-800-GE LAMPS
1-888-GEBALLAST

Order Site	Telephone Number	Facsimile Number
WORLDWIDE CUSTOMER SERVICE CENTER		
O.E.M.	1-800-544-4680	FAX 1-800-544-4845
Government	1-800-624-0624	FAX 1-800-544-4854
Auto OEM	1-800-327-7155	FAX 1-800-327-0588
Quartz	1-800-438-2100	FAX 1-800-258-3803
Commercial & Industrial	1-800-327-0097	FAX 1-800-544-4830
Consumer/Retail	1-800-327-2080	FAX 1-800-544-4850
Wiring Device	1-800-833-4933	FAX 1-800-327-0177

TELESALES:

Commercial & Industrial	1-800-327-7085	FAX 1-800-327-0663
Consumer/Retail	1-800-443-6272	FAX 1-800-327-0663
Auto O.E.M./O.E.M.	1-800-544-4610	FAX 1-800-327-0663
O.E.M.	1-800-544-4780	FAX 1-800-327-0663
Canada	1-800-433-5081	FAX 1-800-327-0063
Quartz	1-800-327-3481	FAX 1-800-327-0063
Government	1-800-624-0601	FAX 1-800-327-0063

CANADA:

French	1-800-443-4916	FAX 1-800-443-4923
English	1-800-443-4925	FAX 1-800-443-4923

NATIONAL ACCOUNT CUSTOMERS:

Mass Merchandisers	1-800-544-4765	FAX 1-800-544-6724
Home Centers/Hardware Branches	1-800-544-4740	FAX 1-800-544-4850

LIGHTING TECHNICAL INFORMATION

Consumer Inquiries	1-800-GE LIGHT (435-4448)
Commercial, Trade Magazine	1-800-GE LAMPS (435-2677)

MASTER DISTRIBUTION CENTERS

ATLANTA	1700 Westgate Parkway, Atlanta, GA 30336
CHICAGO	7770 West 71st Street, Bridgeview, IL 60455
DALLAS	1717 West Airfield Dr., P.O. Box 610847 DFW Airport, TX 75261
HAGERSTOWN	18212 Shawley Dr., Hagerstown, MD 21740
LOS ANGELES	11600 Philadelphia Ave., Mira Loma, CA 91752
OAKVILLE	1300 South Service Road, Oakville, Ontario, Canada L6L 5T7
RAVENNA	150 Loomis Parkway, Ravenna, OH 44266

FOR INTERNATIONAL GE LAMP SALES LOCATIONS, CONTACT:

INTERNATIONAL MARKETING DEPARTMENT, NELA PARK - CLEVELAND, OHIO 44112
PHONE (010-1-216) 266-6889, FAX 266-2371, TELEX 980390

INTERNATIONAL CUSTOMER SERVICE

FRANCHISE EXPORTERS	1-800-327-6886	FAX 1-800-443-5130
INTERNATIONAL CUSTOMERS	1-(804)-965-1015	FAX 1-(804) 965-1018

OEM AREA SALES OFFICES

AUTOMOTIVE	25900 Telegraph Rd., P.O. Box 5011 Southfield, MI 48086-5011	(810) 351-8000
MIDWEST	2021 Spring Rd., Ste. 550 Oak Brook, IL 60522	(630) 573-3866 FAX (630) 573-3917
SOUTH CENTRAL	2080 McDaniel, Carrollton, TX 70056	(972) 888-0521 FAX (972) 888-0525
SOUTHEAST	2001 Westside Pkwy., Suite 190 Alpharetta, GA 30201	(770) 753-3838 FAX (770) 753-3835
NORTH CENTRAL	Nela Park, 1975 Noble Rd. Cleveland, OH 44112	(216) 266-6695 FAX (216) 266-3381
SOUTHERN	8020 Woodland Ctr. Blvd Tampa, FL 33614-2405	(813) 243-3015 FAX (813) 243-3029
MID-ATLANTIC	3000 Hadley Road, 2nd Floor, South Plainfield, NJ 07080	(908) 822-1734 (810) 344-1211
CENTRAL	25945 Arcadia Dr., Novi, MI 48374-2449	(810) 344-1211
SOUTHWEST	16257 Laguna Canyon Rd., Suite 100 Irvine, CA 92618	(714) 450-4780 FAX (714) 450-4752
NORTHWESTERN	1605 NW Sammamish Rd., Suite 300, Issaquah, WA 98027	(206) 557-3065
CANADA	2300 Meadowvale Blvd. Mississauga, ONT L5N 5P9	(905) 858-5372 FAX (905) 858-5653

*Washington, D.C. Telephone Number



GLOSSARY OF TERMS

Amperes

("Amps.") A measure of electrical current. In incandescent lamps, the current is related to voltage and power as follows:
Current (Amps) = Power (Watts) / Voltage (Volts).

American National Standards Institute (ANSI)

A consensus organization which coordinates voluntary standards for the physical, electrical and performance characteristics of lamps, ballasts, luminaires and other lighting and electrical equipment.

Average Rated Life

The median time it takes for a lamp to burn out. For example, a 60-watt Soft White bulb can be expected, on the average, to burn for 1,000 hours. Based upon continuous testing of lamps in laboratories, the 1,000 hour rating is the point in time when 50% of the test samples have burned out and 50% are still burning.

Ballast

An auxiliary piece of equipment designed to start and to properly control the flow of power to gas discharge light sources such as fluorescent and high intensity discharge (HID) lamps.

Beam Angle

The angular dimension of the cone of light from reflectorized lamps (such as R and PAR types) encompassing the central part of the beam out to the angle where the intensity is 50% of maximum. The beam angle sometimes called "beam spread" is often part of the ordering code for reflectorized lamps. Example: The 50PAR30/HIR/NFL25° is a 50 watt PAR30 narrow flood lamp with a beam angle of 25 degrees. See also Field Angle.

Biax®

GE trademark for the biaxial family of high-efficiency and long-life compact fluorescent lamps.

Candela (cd)

The international unit (SI) of luminous intensity. The term has been retained from the early days of lighting when a standard candle of a fixed size and composition was used as a basis for evaluating the intensity of other light sources.

Candlepower

Luminous intensity expressed in candelas. Plots of luminous intensity, called candlepower distribution curves, are used to indicate the intensity distribution characteristics of reflector type lamps.

Chromaticity

See Color Temperature

Coefficient of Utilization (CU)

In general lighting calculations, the fraction of initial lamp lumens that reach the work plane. CU is a function of luminaire intensity distribution, room surface reflectances and room shape.

Color Rendering Index (CRI)

An international system used to rate a lamp's ability to render object colors. The higher the CRI (based upon a 0-100 scale), the better colors appear. CRI ratings of various lamps may be compared, but a numerical comparison is only valid if the lamps are also rated for the same chromaticity. (See Chromaticity.) CRI differences among lamps are not usually significant (visible to the eye) unless the difference is more than 3-5 points.

Color Temperature

Originally, a term used to describe the "whiteness" of incandescent lamp light. Color temperature is directly related to the physical temperature of the filament in incandescent lamps so the Kelvin (absolute) temperature scale is used to describe color temperature. For discharge lamps where no hot filament is involved, the term "correlated color temperature" is used to indicate that the light appears "as if" the discharge lamp is operating at a given color temperature. More recently, the term "chromaticity" has been used in place of color temperature. Chromaticity is expressed either in Kelvins (K) or as "x" and "y" coordinates on the CIE Standard Chromaticity Diagram. Although it may not seem sensible, a higher color temperature (K) describes a visually cooler, bluer light source. Typical color temperatures are 2800K (incandescent), 3000K (halogen), 4100K (cool white or SP41 fluorescent), and 5000K (daylight-simulating fluorescent colors such as Chroma 50 and SPX50).

Compact Fluorescent Lamp (CFL)

The general term applied to families of smaller diameter fluorescent lamps (e.g. T4, T5), some of which have built-in ballasts and medium screw bases for easy replacement of incandescent lamps.

Canadian Standards Association (CSA)

An organization that writes standards and tests lighting equipment for performance as well as electrical and fire safety. Canadian provincial laws generally require that all products sold for consumer use in Canada must have CSA or equivalent approval.

Efficacy

See Luminous Efficacy

Electromagnetic Spectrum

A continuum of electric and magnetic radiation that can be characterized by wavelength or frequency. Visible light encompasses a small part of the electromagnetic spectrum in the region from about 380 nanometers (violet) to 770 nanometers (red) by wavelength.

Electronic Ballast

A short name for a fluorescent high frequency electronic ballast. Electronic ballasts use solid state electronic components and typically operate fluorescent lamps at frequencies in the range of 25-35 kHz. The benefits are: increased lamp efficacy, reduced ballast losses and lighter, smaller ballasts compared to electromagnetic ballasts. Electronic ballasts may also be used with HID lamps, but the circuits are quite different, there are few designs at present and only minor lamp efficacy improvements result.

Elliptical Reflector (ER) Lamp

An incandescent lamp with an elliptically-shaped reflector. This shape produces a focal point directly in front of the lamp which reduces light absorption in some types of luminaires. It is particularly effective at increasing the efficiency of baffled downlights.



Energy Policy Act (EPACT)

Comprehensive energy legislation passed by the U.S. Congress in 1992. The lighting portion includes lamp labeling and minimum energy efficacy (lumens/watt) requirements for many commonly used incandescent and fluorescent lamp types. Similar legislation is being proposed in Canada.

Federal Communications Commission

A U.S. Federal agency which is charged with regulating emissions in the radio frequency portion of the electromagnetic spectrum. For example, a regulation entitled, "Part 18" deals with electromagnetic interference (EMI) from all lighting devices operating at frequencies higher than 9 kilohertz (kHz.). Typical electronically-ballasted compact fluorescent lamps operate in the range of 24-100 kHz.

Field Angle

The angular dimension of the cone of light from reflectorized lamps (such as R and PAR types) encompassing the central part of the beam out to the angle where the intensity is 10% of maximum. See Beam Angle.

Fluorescent Lamp

A high efficiency lamp utilizing an electric discharge through low pressure mercury vapor to produce ultra-violet (UV) energy. The UV excites phosphor materials applied as a thin layer on the inside of a glass tube which makes up the structure of the lamp. The phosphors transform the UV to visible light.

Footcandle (fc)

A unit of illuminance or light falling onto a surface. One footcandle is equal to 1 lumen per square foot. See also Lux.

Genura™ Lamp

A new GE fluorescent light source of a unique design. Features include a reflector shape, built-in high frequency electronic ballast and an electrodeless arc tube. The 23-watt R25 Genura lamp is rated for 1100 initial lumens and 10,000 hours life and is designed to directly replace a 75-watt incandescent reflector lamp.

Halogen Lamp

A short name for the tungsten-halogen lamp. Halogen lamps are high pressure incandescent lamps containing halogen gases such as iodine or bromine which allow the filaments to be operated at higher temperatures and higher efficacies. A high-temperature chemical reaction involving tungsten and the halogen gas recycles evaporated particles of tungsten back onto the filament surface.

Halogen-IR™ (HIR) Lamp

GE designation for a new form of high-efficiency tungsten halogen lamp. HIR lamps utilize shaped filament tubes coated with numerous layers of materials which selectively reflect and transmit infrared energy and light. Reflecting the infrared back onto the filament reduces the power needed to keep the filament hot.

High-Intensity Discharge (HID) Lamp

A general term for mercury, metal halide (GE Multi-Vapor, MXR or Arcstream) and high-pressure sodium (GE Lucalox) lamps. HID lamps contain compact arc tubes which enclose various gases and metal salts operating at relatively high pressures and temperatures.

High-Pressure Sodium (HPS) Lamp

A generic name for GE's Lucalox® lamp. HPS lamps are high intensity discharge light sources which produce light by an electrical discharge through sodium vapor operating at relatively high pressures and temperatures.

Illuminance

The "density" of light (lumens/area) incident on a surface. Illuminance is measured in footcandles or lux.

Incandescent Lamp

A light source which generates light utilizing a thin filament wire (usually of tungsten) heated to white heat by an electric current passing through it.

Infrared Radiation

Electromagnetic energy radiated in the wavelength range of about 770 to 1106 nanometers. Energy in this range cannot be seen by the human eye, but can be sensed as heat by the skin.

Instant Start

A type of fluorescent lamp-ballast circuit designed to start fluorescent lamps as soon as the power is applied. Originally, instant-start circuits were developed to eliminate separate mechanical starter devices. Slimline fluorescent lamps operate only on instant start circuits.

Kilowatt (kW)

A measure of electrical power equal to 1000 watts.

Kilowatt Hour (kWh)

The standard measure of electrical energy and the typical billing unit used by electrical utilities for electricity use. A 100-watt lamp operated for 10 hours consumes 1000 watt-hours (100 x 10) or 1 kilowatt-hour. If the utility charges \$.10/kWh, then the electricity cost for the 10 hours of operation would be 10 cents (1 x \$.10).

Lamp

The term used to refer to the complete light source package including the inner parts as well as the outer bulb or tube. "Lamp", of course, is also commonly used to refer to a type of small light fixture such as a table lamp.

Light

Radiant energy which can be sensed or seen by the human eye. Visible light is measured in lumens.

Light Center Length (L.C.L.)

The distance between the center of the filament or arc tube in a lamp and a reference plane - usually the bottom of the lamp base. See L.C.L. Reference Plane location below.



GLOSSARY OF TERMS (Continued)

L.C.L. Reference Plane Location

Base Type	Location
All Screw Bases (except Mini-Can.)	Bottom of base contact
Mini-Can	Where diameter of ceramic base insulator is .531 inches
3-Contact Medium	Bottom of base contact
Mogul Medium Prefocus	Top of base fins
Mogul Prefocus	Top of base fins
Medium Bipost	Base end of bulb (Glass lamps) Bottom of ceramic base (Quartz lamps)
Mogul Bipost	Shoulder of posts (Glass lamps) Bottom of ceramic base (Quartz lamps)
2-Pin Prefocus	Bottom of ceramic base.
S.C. or D.C. Bayonet Candelabra	Top of base pins
Medium Bayonet	Top of base pins
S.C. or D.C. Prefocus	Plane of locating bosses on prefocus collar
Medium 2-Pin	Bottom of metal base shell

Lumen

The international (SI) unit of luminous flux or quantity of light. For example, a dinner candle provides about 12 lumens. A 60-watt Soft White incandescent lamp provides 840 lumens.

Lumen Maintenance

A measure of how a lamp maintains its light output over time. It may be expressed as a graph of light output vs. time or numerically.

Lumens Per Watt (lpW)

A measure of the efficiency, or, more properly, "efficacy" of a light source. Efficacy is easily calculated by taking the lumen output of a lamp and dividing by the lamp watts. For example, a 100-watt lamp producing 1750 lumens has an efficacy of 17.5 lumens per watt.

Typical lamp efficacies:

Edison's first lamp	1.4 lpw
Incandescent lamps	10-40
Halogen incandescent lamps	20-45
Fluorescent lamps	35-100
Mercury lamps	50-60
Metal-halide lamps	80-115
High-pressure sodium lamps	100-140

Note: the values above for discharge lamps do not include the effect of the ballasts which must be used with those lamps. Taking ballast losses into account reduces "system" or lamp-ballast efficacies - typically by 10-20 percent depending upon the type of ballast used.

Luminaire

A complete lighting unit consisting of a lamp (or lamps), ballast (or ballasts) as required together with the parts designed to distribute the light, position and protect the lamps and connect them to the power supply.

Luminaire Efficiency

The ratio of total lumens emitted by a luminaire to those emitted by the lamp or lamps used.

Luminance

Formerly, a measure of photometric brightness. Luminance has a rather complicated mathematical definition involving the intensity and

direction of light. It should be expressed in candelas per square inch or candelas per square meter although an older unit, the "footlambert", is still sometimes used. Luminance is a measurable quantity whereas brightness is a subjective sensation.

Luminous Efficacy

The light output of a light source divided by the total power input to that source. It is expressed in lumens per watt.

Lux (lx)

The SI (International) unit of illuminance. One lux is equal to 1 lumen per square meter. See also Footcandle.

Maximum Overall Length (M.O.L.)

The end-to-end measurement of a lamp expressed in inches or millimeters.

Mean Lumens

The average light output of a lamp over its rated life. For fluorescent and metal halide lamps, mean lumen ratings are measured at 40% of rated lamp life. For mercury, high pressure sodium and incandescent lamps, mean lumen ratings are measured at 50% of rated lamp life.

Mercury Lamp

A high-intensity discharge light source operating at a relatively high pressure (about 1 atmosphere) and temperature in which most of the light is produced by radiation from excited mercury vapor. Phosphor coatings on some lamp types add additional light and improve color rendering.

Metal Halide Lamp

A high-intensity discharge light source in which the light is produced by the radiation from mercury, plus halides of metals such as sodium, scandium, indium and dysprosium. Some lamp types may also utilize phosphor coatings. GE trade names include: Multi-Vapor®, XL, Watt-Miser®, Chromafit™ and Arcstream®.

Nanometer

A unit of wavelength equal to 10⁻⁹ meter.

PAR Lamp

PAR is an acronym for parabolic aluminized reflector. A PAR lamp which may utilize either an incandescent filament, a halogen filament tube or HID arc tube is a precision pressed-glass reflector lamp. PAR lamps rely on both the internal reflector and prisms in the lens for the control of the light beam.

Phosphor

An inorganic chemical compound processed into a powder and deposited on the inner glass surface of fluorescent tubes and some mercury and metal-halide lamp bulbs. Phosphors are designed to absorb short wavelength ultraviolet radiation and to transform and emit it as visible light.

Power Factor (PF)

A measure of the phase difference between voltage and current on alternating current circuits. Power factors can range from 0 to 1.0 with 1.0 being ideal. Power factor is sometimes expressed as a percent. A high power factor means that an electrical system or device is utilizing power efficiently. Incandescent lamps always have power factors close to 1.0 because they are simple "resistive" loads. The power factor of a discharge



lamp system is determined by the ballast used. "High" power factor usually means a rating of 0.9 or greater. The power factor of "core and coil" electromagnetic ballasts may be as low as 0.5-0.6.

Precise™

The GE trade name for the compact MR-16 and MR-11 low-voltage halogen dichroic "cool beam" reflectorized spot and flood lamps.

Preheat Circuit

A type of fluorescent lamp-ballast circuit used with the first commercial fluorescent lamp products. A push button or automatic switch is used to preheat the lamp cathodes to a glow state. Starting the lamp can then be accomplished using simple "choke" or reactor ballasts.

Quartzline®

A GE registered trademark term for some types of tungsten-halogen lamps.

Rapid Start Circuit

A fluorescent lamp-ballast circuit which utilizes continuous cathode heating, while the system is energized, to start and maintain lamp light output at efficient levels. Rapid start ballasts may be either electromagnetic, electronic or of hybrid designs. Full-range fluorescent lamp dimming is only possible with rapid start systems.

Reflector Lamp

An incandescent, compact fluorescent or HID lamp with a built-in reflecting surface. Incandescent and HID versions are made from a single piece of blow-molded soft or hard glass. CFL versions may be one piece or may be designed so that the inner lamp can be replaced.

Specification Series (SP) Colors

Energy-efficient, all-purpose tri-phosphor fluorescent lamp colors that provide good color rendering (as measured by the Color Rendering Index or CRI). The CRI for SP colors is 70 or above and varies by specific lamp type. Available chromaticities (or "tones") within the SP group include SP30 (3000K) - a good match for the old standard "warm white" color and incandescent or halogen incandescent lamps; SP35 (3500K) - neutral all-purpose tone; SP41 (4100K) - cool in appearance and designed to match the old standard "cool white" color; SP50 - still cooler much like the combination of sun-sky-clouds; SP65 - a color with a very cool appearance, much like north skylight, and designed to match the appearance of the old "daylight" color. SP fluorescent colors are available in most of the widely-used linear lamp types including the T8, T12, slimline, U-tube, high output and 1500 mA types.

Specification Series Deluxe (SPX) Colors

Energy-efficient tri-phosphor fluorescent lamp colors that provide better color rendering (as measured by the Color Rendering Index or CRI) than Specification Series colors. The CRI for SPX colors is 80 or higher and varies by specific lamp type. Available chromaticities within the SPX group include SPX27 (2700K) - a visually "warm" tone intended to match the visual appearance of low wattage incandescent lamps; SPX30 (3000K) - a good match with high wattage incandescent and halogen incandescent lamps; SPX35 (3500K) - a widely-used, neutral all-purpose tone; SPX41 (4100K) - cool in appearance and SPX50 - a "daylight simulating" color with a very cool appearance much like skylight. SPX fluorescent colors are available in most of the widely-used lamp types including T8, T12, U-tube and high-lumen Biax types. GE compact fluorescent lamps (CFL's) typically use only SPX colors.

Spectral Power Distribution (SPD)

A graph of the radiant power emitted by a light source as a function of wavelength. SPD's provide a visual profile or "finger print" of the color characteristics of the source throughout the visible part of the spectrum.

TCLP Test

The Toxicity Characteristic Leaching Procedure (TCLP) test, specified in the Resource Conservation and Recovery Act (RCRA) of 1990, is used to characterize fluorescent lamp waste as hazardous or nonhazardous waste. The TCLP test measures the ability of the mercury in a lamp to leach from a landfill into ground water under very aggressive and reactive conditions.

Total Harmonic Distortion (THD)

A measure of the distortion of the sine wave on alternating current (ac) systems caused by higher order waves superimposed on the fundamental (usually 60 Hz.) frequency of the system. THD is expressed in percent and may refer to individual electrical loads (such as a ballast) or a total electrical circuit or system in a building. The ANSI recommendation is for THD to be no greater than 32% although some electrical utilities may require lower THD's on some systems. Excessive THD's on electrical systems can cause efficiency losses as well as overheating and deterioration of system components.

Voltage

A measurement of the electromotive force in an electrical circuit or device expressed in volts. Voltage can be thought of as being analogous to the pressure in a waterline.

Watt

A unit of electrical power. Lamps are rated in watts to indicate their power consumption. Power consumed over time equals the electrical energy used.

Watt-Miser®

A Watt-Miser lamp is a term used by GE to indicate a reduced-wattage lamp with performance characteristics (life, light output, etc.) such that it can usually directly replace a higher-wattage product. Watt-Miser lamps are available in a wide range of incandescent, fluorescent and HID lamp types.

Underwriters Laboratories (UL)

A private organization which tests and lists electrical (and other) equipment for electrical and fire safety according to recognized UL and other standards. A UL listing is not an indication of overall performance. Lamps are not UL listed except for compact fluorescent lamp assemblies - those with screw bases and built-in ballasts.

Ultraviolet (UV) Radiation

Radiant energy in the range of about 100-380 nanometers (nm). For practical applications, the UV band is broken down further as follows:

Ozone-producing	180-220 nm
Bactericidal (germicidal)	220-300
Erythemat (skin reddening)	280-320
"Black" light	320-400

The International Commission on Illumination (CIE) defines the UV band as UV-A (315-400 nm); UV-B (280-315 nm) and UV-C (100-280 nm).



selecting the best color or lamp

Color Rendering

Chromaticity Data

for Incandescent, Fluorescent & HID

The Color Rendering Index chart at right shows both dimensions of light source color — chromaticity and color rendering — for the most popular light sources. Designers often choose a chromaticity first to match the “atmosphere” appropriate for the application. Then a light source at that chromaticity is picked with the highest color rendering, and best performance and physical characteristics to meet the requirements of the installation.

BETTER COLOR RENDERING FOR BETTER APPEARANCE

The color rendering of a light source describes that source’s ability to accurately render the colors of perceived objects – people and things. As a general rule, the higher a light source’s color rendering index (CRI or R_a) number, the better the lamp will make things appear. SP lamps have CRI’s of 70+ making them better color-rendering light sources than older standard fluorescent lamps.

YOUR CHOICE – “WARM” OR “COOL”

A second consideration in light-source selection is the degree of visual “coolness” or “warmth” of the light source.

- Lamps with chromaticity values of 4000 kelvins (K) and higher are considered visually “cool”
- Lamps with values between 3000K and 4000K are moderate in tone
- Lamps at 3000K and lower are described as “warm”
- GE SP30 and SPX30 lamps produce a warm appearance, slightly enhancing reds and yellows
- SP35 and SPX35 lamps produce a balanced tone, midway between warm and cool
- SP41 and SPX41 lamps are cooler in tone, slightly biased toward blues and greens
- SP50 and SPX50 are very cool, high color rendering light sources, designed to simulate natural outdoor daylight at high efficiency
- SP65 provides very cool light similar to the “north sky” and is considered an ideal substitute for Daylight color lamps

THE DESIGNATIONS ARE FOR THESE LAMPS

SP30	Specification Series 3000K Fluorescent
SP35	Specification Series 3500K Fluorescent
SP41	Specification Series 4100K Fluorescent
SP65	Specification Series 6500K Fluorescent
SPX27	Deluxe Specification Series 2700K Fluorescent
SPX30	Deluxe Specification Series 3000K Fluorescent
SPX35	Deluxe Specification Series 3500K Fluorescent
SPX41	Deluxe Specification Series 4100K Fluorescent
SPX50	Deluxe Specification Series 5000K Fluorescent
CW	Cool White, Fluorescent
WW	Warm White, Fluorescent
C50	Chroma 50, Fluorescent
INC	Incandescent
H/DX	Mercury Deluxe White
MVR	Multi-Vapor®
MVR/SP30	Multi-Vapor, Phosphor Coated
LU/DX	Deluxe Lucalox®

DESCRIBING LIGHT-SOURCE COLOR

The pictures are intended, within the limits of modern high-speed printing, to give a good indication of the differences between SP and SPX colors, at various chromaticities.

Note: Color Rendering (R_a) Index Values in () for "F40" lamps.

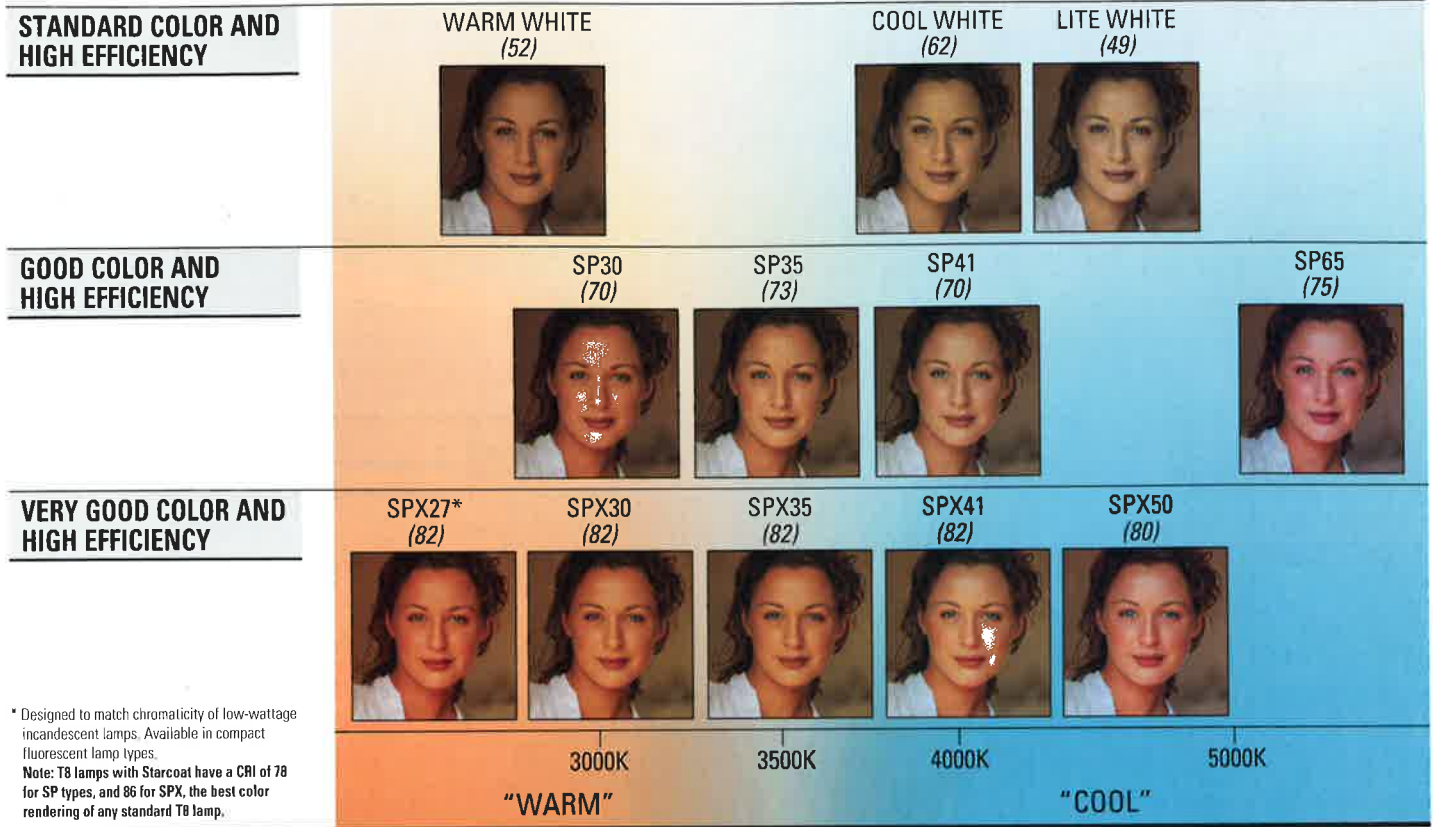

* Designed to match chromaticity of low-wattage incandescent lamps. Available in compact fluorescent lamp types.

Note: T8 lamps with Starcoat have a CRI of 78 for SP types, and 86 for SPX, the best color rendering of any standard T8 lamp.

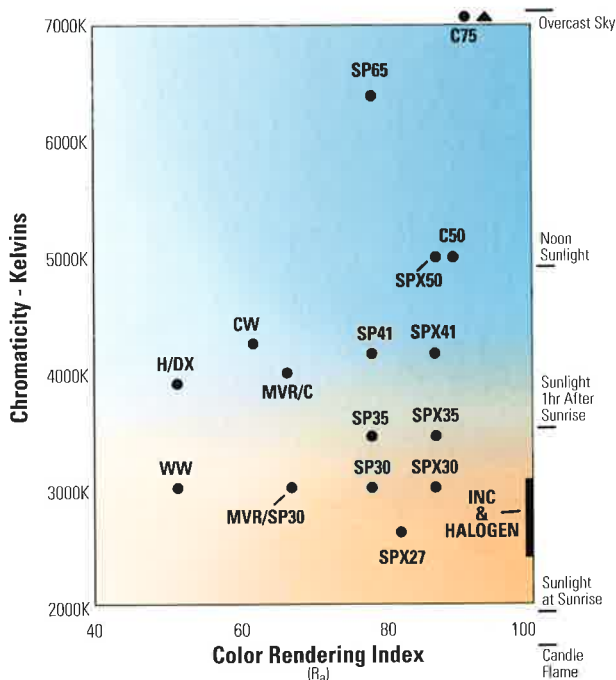

SUGGESTED COLOR APPLICATIONS FOR HID LAMPS

Clear Mercury	Landscape lighting, specialized floodlighting such as green copper roofs.
DX Mercury	Stores, public spaces — Multi-Vapor® however, are preferred.
MV	Stores, public spaces, industrial, gymnasiums, floodlighting signs & buildings, parking areas, sports.
MVR/C	Same as MV — warmer color — diffuse coating reduces brightness.
MVR/SP30	Same as MV — warmer than MV or MV/C — matches SP30 fluorescent.
LU	Street lighting, parking areas, industrial, floodlighting, security, CCTV.
LU/DX	Floodlighting, parking areas, indoor/ outdoor pedestrian malls, industrial, security, roadway.



GE Lighting

86040 (3/99)
Printed in U.S.A.